

Microbiology Lab Manual: Discovering Your Tiny Neighbors

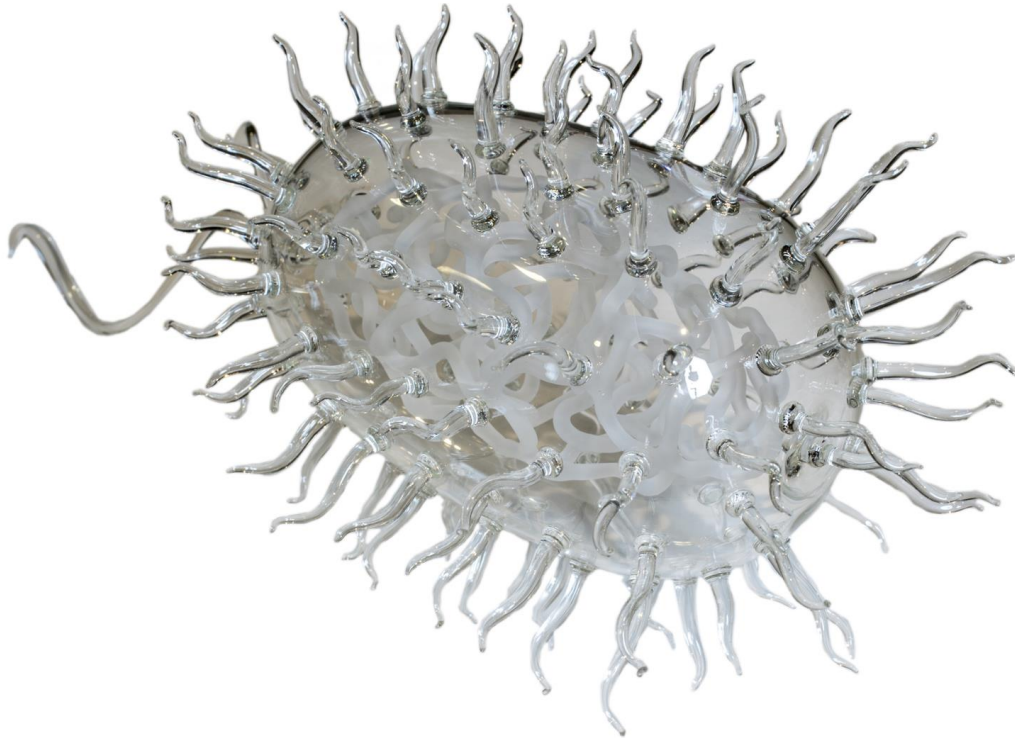

Lab Manual for Microbiology 22

Mt. San Antonio College

Revised May 2019

Assembled by Chris Briggs, from numerous sources

Photo of Luke Jerram's blown glass sculpture by Matteo De Stefano/MUSE Science Museum, Trento, Italy.

Table of Contents

Orientation and Safety

Part 1: Microscopy

Exercise 1: The Microscope and Bacteria

Part 2: Handling, Growing, and Simple Staining Bacteria

Exercise 2: Culturing your Environment

Exercise 3: Media and Aseptic Techniques

Exercise 4: Simple Stains

Part 3: Differential and Structural Staining

Exercise 5: Gram Stain, Acid-Fast Stain, and Spore Stain
Identification of Unknown Bacteria

Part 4: Eukaryotic Microorganisms

Exercise 6: Fungi

Exercise 7: Protists

Exercise 8: Parasitic Worms and Arthropod Vectors

Part 5: Cultivation and Identification of Bacteria

Exercise 9: Pure Culture Techniques

Exercise 10: Isolation of Pathogens

Exercise 11: More Tests of an Unknown Bacterium

Exercise 12: Rapid Bacterial Identification

Exercise 13: Summary of UTI Results

Part 6: Control of Microbial Growth

Exercise 14: Susceptibility to Antibiotics, Dyes, and Metals

Exercise 15: Heat, Cold, Drying, and Radiant Energy

Exercise 16: Antibacterial Products

Part 7: Epidemiology and Immunology

Exercise 17: HIV Epidemic and Detection with ELISA

Part 8: Microbial Genetics

Exercise 18: Bacterial Transformation

Part 9: Water and Milk Microorganisms

Exercise 19: Testing Water and Milk

Acknowledgements

This lab manual is largely the result of work by Mt. San Antonio College microbiology instructors. Many of the lab exercises were developed by Dr. Lou Shainberg, who taught at Mt. SAC for 45 years, from 1962 until he died in 2006. Lou was a role model, mentor, and beloved colleague of Mt. SAC microbiology professor Cindy Anderson. Cindy has further developed this lab manual in her many years of teaching. Some of the text and several images have been adapted from an open-source lab manual by Joan Petersen and Susan McLaughlin at CUNY Queensborough Community College.

In addition, this manual has benefited from valuable input and suggestions from numerous Mt. SAC microbiology instructors, including Monica Lee, Dr. Raminder Kaur, Dr. Jessica Spitzer, Dr. Kaushiki Menon, and Nan Shea. The labs have also relied on the careful attention of our laboratory technicians Donna Lee, Ana Jara de Araya, and Naomi Velarde-Jang.

And to our students, welcome to the exciting world of microbiology! Please enjoy your exploration and investigation. I am always interested to hear your feedback on this manual.

Chris Briggs
Professor and Course Coordinator
cbriggs5@mtsac.edu

Orientation and Safety

Welcome to Microbiology Lab!

Student preparation

- Doing well in lab requires regular attendance. Students who miss more than two weeks of lab (or three days in winter or summer sessions) will be dropped from class.
- Read the exercise before coming to lab.
- Bring your lab manual to each lab meeting.
- Reach out to your classmates to develop friendships. The class will be even more enjoyable that way.
- Labs will fill the entire lab period, so plan to stay until the end.

Useful references

- Lab manual
 - Course textbook
 - A Photographic Atlas for the Microbiology Laboratory, by Leboffe and Pierce. This contains full-color photographs.
 - www.microbelibrary.org and www.microbeworld.org. These contain images, videos, and more.
-

Safety instructions

Our lab can be an interesting and exciting place, but it includes potential hazards. Improper handling of chemicals, equipment, or microbial cultures is dangerous and can result in injury or infection. The instructions below are designed to keep you safe in the laboratory. Please read them carefully. If you have any questions about safe laboratory practices, ask your instructor.

General preparedness

1. Come to lab on time and prepared for that day's experiments. If you miss oral instructions, this can be dangerous to you and to your classmates.
2. Make sure to carefully read through the entire procedure before beginning an experiment in the lab. This will help prevent you from making mistakes that could compromise your safety.
3. Follow all directions given by the instructor. Bring any safety concerns to the attention of the instructor.
4. No eating, drinking, or smoking at any time. Do not bring food or drink items into the lab.
5. Avoid all hand-to-mouth, finger-to-mouth, and finger-to-eye contact. (Break the habit of licking your fingers to turn pages, or of putting pencils in your mouth.) Never apply cosmetics or insert contact lenses in the laboratory.
6. Wash hands, and wipe down bench area with disinfectant prior to working. Before you leave the lab for the day wipe down your bench area with disinfectant and then wash your hands. Wash your hands at any time during the lab if you think you may have contaminated them. Wipe any surfaces or equipment with disinfectant immediately if you suspect contamination with living cultures.
7. Keep your desk and floor free of non-essential materials at all times (including cell phones, since they do not respond well to being soaked in disinfectant).
8. Know where the fire extinguisher, emergency eye/face wash and shower are located in our laboratory. Make sure chairs are not blocking the room's exits.
9. To remain in the lab, you must use proper personal protective equipment. This includes a lab coat that goes to your knees

(long sleeved and buttoned/closed in front), closed-toe shoes that cover the top of your foot, and clothing that covers your legs (no shorts or short dresses). Any open wounds should be covered and protected before entering the lab. Open-toed shoes (sandals, flip-flops etc.) cannot be worn in lab.

10. Wax pencils and permanent markers are useful for writing on glassware and microscope slides. Please do not write on any white frosted portions of glassware, because the marks are very difficult to remove.
11. Never remove media, equipment, or bacterial cultures from the lab.
12. For liability and safety reasons, no visitors are allowed in the laboratory.

When working with bacteria or hazardous chemicals

13. Loose clothing and long hair must be tied back while working to avoid inadvertent contamination.
14. Wear gloves and eye protection whenever hazardous chemicals or living cultures are handled.
15. Always handle cultures with care. Keep tubes in a test tube rack to prevent accidental spillage. Hot test tubes should be handled with test tube holders.
16. Treat all living cultures of microorganisms (bacteria, yeast, etc.) as potential pathogens. Avoid spilling or spreading the microorganisms. Place all used materials in the appropriate waste containers designated for cultures (to be autoclaved). Use the techniques specified by the instructor for handling microorganisms.
17. If there is a spill, immediately cover spilled cultures or broken culture tubes with paper towels and then saturate the paper towels with germicide. Notify your instructor. After 15 minutes of reaction time, remove the towels and dispose of them in a manner indicated by your instructor. Broken glass is swept up with brush and dustpan, and discarded into a

dedicated broken glass container.

18. Immediately report any incidents such as cuts or burns to the instructor.
19. Do not put contaminated instruments, such as inoculating loops, needles, or pipettes, on bench tops. Loops and needles must be sterilized by incineration.
20. Never pipette by mouth. Proper pipetting is carried out with the aid of a mechanical pipetting device, and the cotton plug in the top of the disposable pipettes is to be left alone.

When using Bacti-Cinerators

21. Bacti-Cinerators will reach optimum sterilizing temperature (1500°F/815°C) after 10 minutes. Please turn off the Bacti-Cinerator at the end of lab, but leave it plugged in. (The plugs last longest when the wires are not tugged.)
22. Do not let your inoculating loops or needles stay inside the Bacti-Cinerator unattended! They can fall out, and will weaken rapidly if heated too long.

Disposal and clean-up

23. The most critical (and most expensive) piece of equipment in the microbiology laboratory is the microscope. If you expect to see specimens through the microscope, it must be kept clean and in good condition. Instructions for the use and care of the microscope can be found in Lab 1 of the lab manual. Report any problems with your microscope to your instructor.
24. Do not use tape on plates or reusable materials because the tape is too difficult to remove.
25. Remove rubber bands before discarding test tubes or plates.
26. Dispose of contaminated plates, pipettes, and cotton swabs in the autoclave container ("burn box").
27. Dispose of contaminated test tubes in the wire baskets provided.

28. Dispose of all glass coverslips and broken-non repairable slides in the broken glass container.
29. Live mounts of hazardous organisms must be soaked in germicide for 15 minutes, before washing with soap and water. (Stained slides can be washed with soap without soaking in germicide first, since organisms on stained slides are killed by the staining process.) Clean and dry all slides before returning them to their proper boxes.
30. Remove oil from prepared slides with lens paper.
31. Any papers on the floor at the end of the laboratory period are to be picked up and discarded in the wastebasket. The same is true for your laboratory bench area.
32. DO NOT put plates, tubes, swabs, slides, pipettes, pipette tips, or broken glass into the regular garbage. These items need to be disposed of properly. Throwing potentially contaminated items into the regular garbage is a safety issue for students, instructors, lab technicians, and the cleaning staff. If these items are found in the regular garbage the ENTIRE BAG OF GARBAGE must be autoclaved before disposal. If you are unsure about where an item should go, feel free to ask your instructor.

Name _____

Date _____

Section # _____

Part 1: Microscopy

Exercise 1: The Microscope and Bacteria

Objectives

1. Learn metric prefixes that are commonly used in microbiology.
2. Get comfortable converting between metric units.
3. Review the taxonomic classification system used in scientific nomenclature.
4. Identify the parts of the compound microscope and describe their functions.
5. Safely transport the microscope.
6. Properly clean the microscope.
7. Store the microscope safely.
8. Use the microscope to view slides of several different cell types, including the use of the oil immersion lens to view bacterial cells.
9. Use terms to describe the shapes and arrangements of some common types of bacteria.

Introduction to Metric Units

Since people all over the world use the metric system of units, this is the most useful system for science. Some metric units commonly used in microbiology are listed below.

- The basic unit of length is the meter.
- There are 1000 millimeters (mm) in one meter. $1 \text{ mm} = 10^{-3} \text{ meter}$
- There are 1000 micrometers (microns, or μm) in one millimeter. $1 \mu\text{m} = 10^{-6} \text{ meter}$
- There are 1000 nanometers in one micrometer. $1 \text{ nm} = 10^{-9} \text{ meter}$

Instructions

Please complete these tables, and solve the conversion problems that follow.

Unit	Abbreviation
Length	
Mass	
Volume	

		Power of 10	Prefix	Abbrev.	Length	Mass	Volume
1,000	one thousand	_____	kilo-	k	km	kg	kL
100	one hundred	10^2	_____	h	_____	_____	_____
1	one.	10^0	none	---	m	g	L
1/100	one hundredth	$1/10^2 = 10^{-2}$	_____	c	_____	_____	_____
1/1,000	one thousandth	_____	_____	m	_____	_____	_____
1/1,000,000	one millionth	_____	_____	μ	_____	_____	_____
1/1,000,000,000	one billionth	_____	nano-	n	nm	ng	nL

Note: Ten angstroms (\AA) make one nanometer.

Gaining familiarity

1 meter = about the height of a doorknob, or
 = about the distance from the floor to the top of your hip bone, or
 = about the height of the lab bench.

Which of these is closest to one meter? _____

On your hand, find a one-centimeter length. Is it the length of a particular finger joint? Or the width of a particular fingernail?

One millimeter is about the thickness of ten sheets of paper. What else is about this size?

One micrometer is about 1/100 of the thickness of a single sheet of paper.

Conversion practice

1. $1 \text{ m} = ? \text{ mm}$
2. $1 \text{ m} = ? \mu\text{m}/\text{mcm}/\text{micrometers}$
3. $1 \text{ g} = ? \text{ ng}$
4. $1 \text{ mL} = ? \mu\text{L}/\text{mcl}/\text{microliters}$
5. $1 \text{ mm} = ? \text{ nm}$
6. $610 \mu\text{g}/\text{mcg}/\text{micrograms} = ? \text{ mg}$
7. $46 \text{ mm} = ? \text{ m}$
8. If a microorganism is $10 \mu\text{m}$ long, how long is it in nanometers?
9. If the diameter of the field of view in your microscope is 2 mm under low power, and one *Bacillus* cell is $2 \mu\text{m}$ long, how many *Bacillus* cells would it take to reach all the way across this field of view?
10. If yeast cells measure $10 \mu\text{m}$ in length, how many yeast cells would it take to reach across this same field of view?
11. A patient has an order for 250 mg of ciprofloxacin every 12 hours. How many grams will the patient be taking over the course of 4 days?

Introduction to Scientific Nomenclature

Scientific nomenclature is based on a taxonomic classification system. Taxonomic classification is a hierarchical system used to classify and compare organisms. There are eight ranks in this system, listed below in order of the most general (broadest) to the most specific:

Domain, Kingdom, Phylum, Class, Order,
Family, Genus, Species

Prokaryotic organisms like bacteria may have classifications below the species level, including strain, subspecies, serotype, morphotype, or variety.

Taxonomic classification indicates how closely organisms are related. For example, two organisms sharing the same Class are more closely related than two organisms sharing the same Phylum.

Binomial nomenclature: The scientific name of an organism consists of two words: the genus name and the specific epithet. The genus name comes first and is always capitalized; once identified it can be abbreviated to a single letter. The second word is known as the specific epithet and is not

capitalized. The two words together make up the scientific name or species name. The genus can be used alone (you can refer to the genus *Staphylococcus* or the genus *Bacillus*) but the specific epithet without the genus name has no scientific significance. Scientific names in print should always be either italicized or underlined and should always be underlined when handwritten. For example, the scientific name for human beings is *Homo sapiens* or *H. sapiens*. The scientific name of a bacterium is *Staphylococcus aureus* or *S. aureus*.

The scientific name often includes a description of the characteristics of an organism. The scientific name *Staphylococcus aureus* tells you the morphology and arrangement of the individual cells belonging to this bacterial genus (staphylococcus = spheres in clusters) and also tells you that *S. aureus* often grows in colonies with a golden color (“aureus”). Although scientific names are often descriptive, occasionally these descriptions can be deceiving. For example, *Haemophilus influenza* is a bacterium (not a virus), and does not cause influenza.

Introduction to Microscopes

The first microscope was developed in 1590 by Dutch lens grinders Hans and Zacharias Jansen. In 1667, Robert Hooke described the microscopic appearance of cork and used the term “cell” to describe the compartments he observed. Anton van Leeuwenhoek was the first person to observe living cells under the microscope in 1675—he described many types of cells, including bacteria. Since then more sophisticated and powerful scopes have been developed that allow for higher magnification and clearer images.

Microscopy is used by scientists and health care professionals for many purposes, including diagnosis of infectious diseases, identification of microorganisms (microscopic organisms) in environmental samples (including food and water), and determination of the effect of pathogenic (disease-causing) microbes on human cells. This exercise will familiarize you with the microscopes we will be using to look at various types of microorganisms throughout the semester.

The light microscope

What does it mean to be microscopic? Objects are said to be microscopic when they are too small to be seen with the unaided eye—they need to be magnified (enlarged) for the human eye to be able to see them. This includes human cells and many other types of cells that you will be studying in this class.

The microscope you will be using uses visible light and two sets of lenses to produce a magnified image. The total magnification will depend on which objective lens you are using—the highest magnification possible on these microscopes is 1000X—meaning that objects appear 1000X larger than they actually are.

Resolution vs. magnification

Magnification refers to the process of making an object appear larger than it is; whereas resolution is the ability to see objects clearly enough to tell

two distinct objects apart. Although it is possible to magnify above 1000X, a higher magnification would result in a blurry image. (Think about magnifying a digital photograph beyond the point where you can see the image clearly). This is due to the limitations of visible light (details that are smaller than the wavelength of light used cannot be resolved).

The limit of resolution of the human eye is about 0.1 mm, or 100 microns. Objects that are smaller than this cannot be seen clearly without magnification. Since most cells are much smaller than 100 microns, we need to use microscopes to see them.

The limit of resolution of the light microscope you will be using today is about 0.1 μm , or 100 nm. This means that we can view objects that are 1000X smaller than what we can see with our eyes alone. Biologists typically use microscopes to view all types of cells, including plant cells, animal cells, protozoa, algae, fungi and bacteria. The nucleus and chloroplasts of eukaryotic cells can also be seen—however smaller organelles and viruses are beyond the limit of resolution of the light microscope.

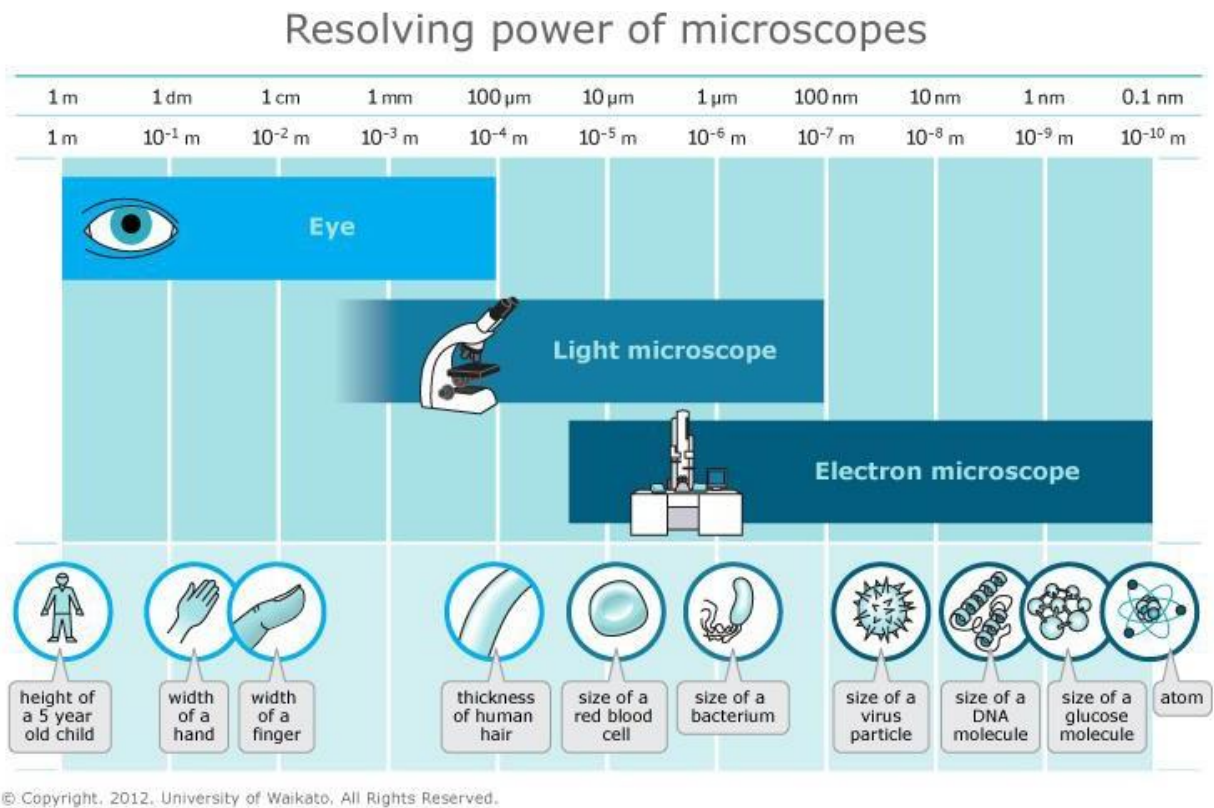

Figure of relative resolving power from Petersen, J. and S. McLaughlin, 2016.

Diversity of Cells

There are many types of cells found among the diverse forms of life on the planet. All cells have certain features in common, such as a plasma membrane surrounding the cell, cytoplasm within the plasma membrane, and DNA as the molecule that stores genetic material. However, there is a great deal of diversity among the cells that make up

living organisms.

Some living organisms are composed of one cell (unicellular); others are composed of many cells (multicellular). Cells that have a nucleus and other organelles are eukaryotic; bacterial cells do not have these intracellular structures—they are

prokaryotic.

Some types of cells (plants, algae and some bacteria) are photosynthetic (capable of using light energy to make organic compounds from inorganic materials.) Others take in organic molecules as a source of energy.

There are several other similarities and differences among cell types that you will learn about throughout the semester. In today's lab you will use the microscope to look at various types of cells that are often studied in a microbiology course. In this activity you will look at some prepared slides, as well as make a few of your own.

Parts of the Light Microscope

Ocular (eyepiece): what you look through to view your slide. Our microscopes are binocular, which means they have two eyepiece tubes and both eyes are used (monocular microscopes have only one tube). Typically ocular lenses magnify an image 10X, although some have other magnifications (ex: 12X). Binocular microscopes allow for adjustment of the distance between pupils so that both eyes can be used to observe one image.

Objective lenses are the lenses close to the stage. Usually microscopes will have 3–5 lenses of different magnifications (ours have four: 4X, 10X, 40X, and 100X magnifications). Objective lenses are located on a rotating turret to allow for changes in magnification.

Coarse adjustment knob: the larger (and outermost) of the two focusing knobs—moves the stage toward or away from the objectives to bring the image into focus at low power.

Fine adjustment knob: smaller knob within the coarse adjustment knob—used for “fine-tuning” an image. Only fine focus can be used when the 40X and 100X objectives are in place.

Stage: the platform where the slide to be viewed is placed. A mechanical stage holds the slide in place and allows for the movement of the slide to view different areas.

Illuminator (light source): found at the base (bottom) of the microscope below the stage.

Condenser/iris diaphragm assembly: found directly beneath the stage. This assembly can be raised and lowered using a knob at the side of the microscope. For our purposes, the assembly should be positioned very close to the bottom of the stage. The condenser is a lens that focuses the light from the illuminator onto the specimen. The iris diaphragm controls the amount of light that passes through the specimen. The iris diaphragm can be opened and closed by twisting the ridged ring of the assembly.

Base: the bottom-most part of the microscope that contains the illuminator.

Arm: positions the objective lenses and the oculars above the stage. When moving the microscope, the base should be supported with one hand, while the arm is grasped with the other hand.

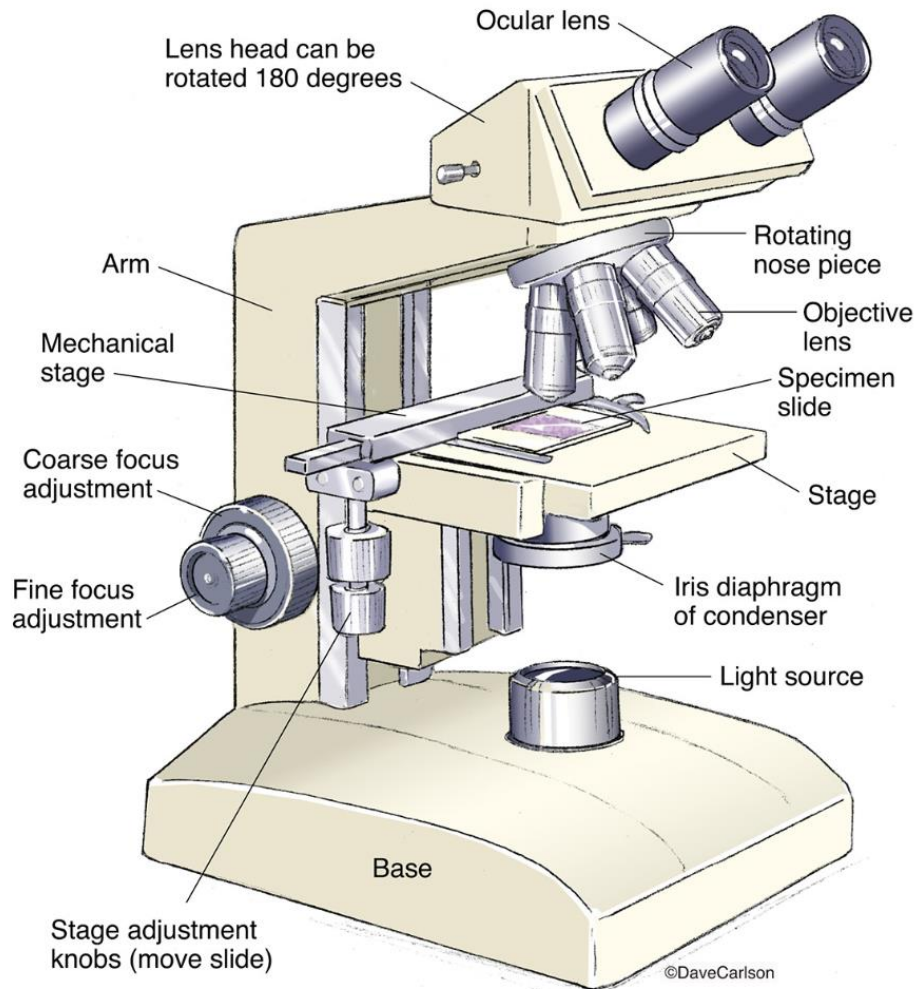

Microscope figure from Carlson Stock Art.

Total Magnification

The microscope you are using has two sets of lenses that both contribute to the total magnification of the image. The ocular lenses magnify your image 10X. There are 4 different objective lenses—each with a different magnification. The total magnification is calculated as follows:

$$\text{Total magnification} = \text{ocular magnification} \times \text{objective magnification}$$

Since the ocular magnification of our microscope is 10X, determining the total magnification of an object with this microscope simply requires multiplying the objective magnification by 10. (Note: other microscopes may have ocular lenses with a different magnification, for example 12X.)

Use and Care of the Microscope

1. Always carry the microscope with two hands.
2. Clean the lenses with lens cleaner and lens tissue before and after use.
3. Report any problems with the microscope to your instructor immediately.
4. Oil must be cleaned off completely before returning the microscope to the cabinet. If you accidentally get oil on the 40X objective, clean it immediately. Microscopes must always be returned to the cabinet clean.
5. Microscopes should always be put away with a low power objective (4X or 10X) over the stage.
6. Always lift the microscope to reposition it—do not drag it across the surface of the table!

Review Questions

1. Use your knowledge and observations to fill in the chart below.

Name of lens	Objective magnification	Ocular magnification	Total magnification
Scanning			
Low			
High-dry			
Oil immersion			

2. Match each part to its function.

Stage	Closes down the amount of light, and sharpens image.
Stage adjustment knobs	Lifts or lowers the condenser; the closer to the specimen the better.
Light intensity knob	Should be set so that both eyepieces are the same length.
Interpupillary adjustment	Moves a slide side-to-side and front-to-back.
Coarse focus knob	Changes lamp brightness.
Fine focus knob	Should only be detached by holding the plug.
Iris diaphragm	Aligns light waves before they pass through specimen.
Condenser	Provides flat surface for specimens.
Condenser adjustment lever	Allows both eyes to see an image simultaneously.
Specimen holder	Holds a slide in place on the stage.
Eyepiece length adjustment ¹	Moves the stage up and down in tiny amounts.
Electrical cord	Moves the stage up and down rapidly.

¹ Some microscopes have this length indicated by a white ring, or a white dot, or by a line that is aligned with a “0.”

3. Please number these steps, in the order they should be completed when using a microscope.

Remove specimen, lower stage, wrap cord, and return covered microscope to numbered shelf.

Move to other objective lenses to increase magnification.

Rotate lowest-magnification objective lens into position (probably 4x or 10x).

Clean all lenses with lens paper.

Place specimen on stage.

Adjust chair to a comfortable height.

Use coarse focus knob to adjust stage until an image is visible.

Be careful to use only the fine focus knob with the longest objective lenses.

4. Please label the diagram with the following microscope parts:

- A. Arm
- B. Base
- C. Coarse focus knob
- D. Condenser
- E. Condenser adjustment knob
- F. Diopter adjustment mark
- G. Eyepiece width adjustment
- H. Fine focus knob
- I. Forward/backward and Lateral motion knobs
- J. High power lens
- K. Iris diaphragm
- L. Low power lens
- M. Ocular lenses
- N. Oil immersion lens
- O. Revolving nosepiece
- P. Scanning lens
- Q. Slide holder
- R. Stage
- S. Substage lamp



Materials

- Prepared slides: Crossed silk threads, mixed bacterial types, *Escherichia coli*, *Staphylococcus aureus*, *Proteus vulgaris*
 - Piece of millimeter ruler
 - Slides and cover slips
 - Pond water sample (if available)
 - Sterile toothpicks
 - Methylene blue stain
 - Prepared plates with bacterial colonies
-

Instructions

1. When instructed to do so, obtain a microscope. Familiarize yourself with the major parts and their functions.
2. Place any slide on the mechanical stage and make sure that it is level and held firmly in place. Your sample/smear should be facing upwards.
3. Use the knobs located below the stage to move the slide left and right, and up and down until the stained area of the slide is centered over the light source.
4. Position the scanning power objective (4X) in place over the slide. (Note: Objective will “click” into place.)
5. Everyone's eyes are a different distance apart. Adjust the distance between the eyepieces so that you can comfortably look through both eyepieces at the same time.
6. Check that the eyepieces are the same length. (The length can also be adjusted to compensate for uncorrected vision problems.) There are length indicator marks on the eyepieces -- usually dots or rings.
7. Move the condenser up to the stage for stained specimens, or lower for living material.
8. Adjust the iris diaphragm to allow enough light to pass through the specimen. Too little light can make a dim image, and too much light can make the details hard to see.
9. Use the coarse adjustment knob to bring the stage up as far as it will go. When using the scanning or low power objectives the working distance (the distance between the lens and the slide) is large enough so that the slide will never make contact with the lens. This is not the case when using the high-dry and oil immersion lenses, where the working distance is significantly less. This is why the coarse adjustment knob can only be used with the two low-power lenses.
10. Rotate the coarse adjustment knob away from you until the image comes into focus. You will not be able to make out much detail at this power—the purpose is to find where your specimen is on the slide so that it is easier to locate when you switch to high power. Low power objectives have a large field of view (the circular area seen when looking through the microscope) and a large depth of field (the thickness of a specimen that is in sharp focus). As magnification increases, both the field of view and depth of field decrease, which is why it is easier to locate your specimen using a low power objective.
11. If needed, use the fine adjustment knob to improve the clarity of the image.

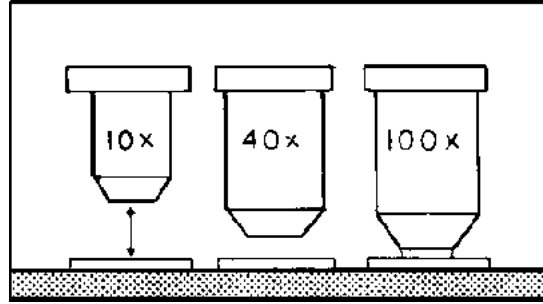

Working distance image from Basic Malaria Microscopy (part I and II) WHO - OMS, 1991.

12. After viewing the slide at scanning power, move the slide so that the area you want to focus on is in the center of the field of view.

Since your microscope is parcentric, when you increase magnification you will be zooming in at the center of the field of view. Objects that are not centered at low power may be out of the field of view at high power.

13. Rotate the objective lens nosepiece so that the 10X objective is in place over the slide. Re-focus and adjust the light (if needed) under the 10X objective.

The microscope you are using is parfocal—this means that when it is in focus with one lens in place the same stage position will be in focus with all other lenses. Therefore when switching objectives, DO NOT change the position of the stage—just click the objective you wish to use into place.

Note the differences in the appearance of the cells from when you were using the 4X objective.

14. After focusing at 10X, rotate the objective lens nosepiece so that the 40X objective is positioned over the slide. Re-focus using the fine adjustment knob and adjust the light if needed.

Note: Remember that you CANNOT use the coarse adjustment knob at high power

(40X or 100X objectives). When you are using the high-power lenses the lens is very close to the slide (small working distance) therefore using the coarse adjustment knob at high power could result in damage to the lens, damage to the slide, or both.

Remember to use the spaces provided at the end of this exercise to draw pictures as you are viewing the slides.

15. When you are finished looking at a slide, return it to the slide box and proceed to the next slide.
16. View the slide with crossed silk threads. Which color thread is on top? How can you tell? Draw and label your observations.

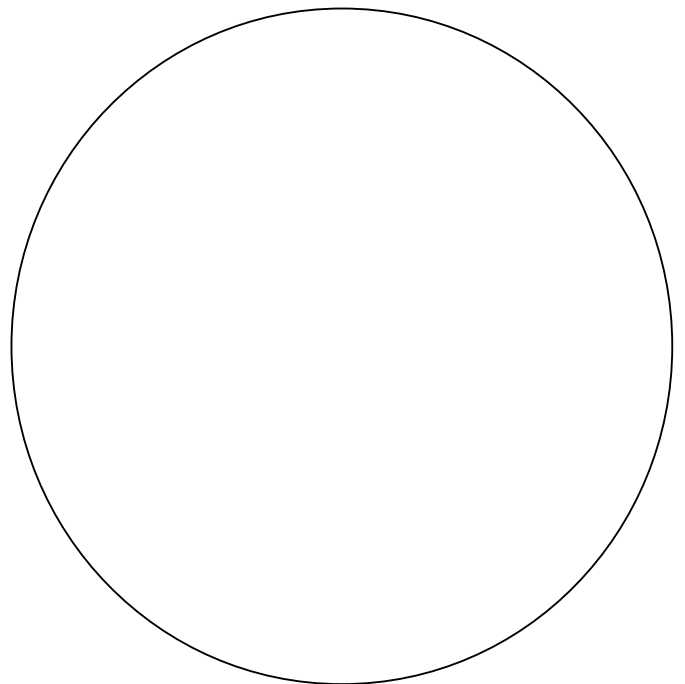

17. Use a piece of millimeter ruler to estimate the width of the field of view. It may help to place the ruler on top of a slide.

How wide is the field of view under scanning power?

Low power?

High power?

Preparation of Wet Mounts

These slides will be prepared with live microbes on them. Since the liquid is left on the slide, cover slips are needed to prevent this liquid from touching the lenses.

18. Live protozoa: Use a dropper to place 1–2 drops of a pond water sample onto a clean microscope slide. Try to get some solid material from the bottom of the beaker. Take a cover slip and place it down over the water as shown in the diagram. (This method helps avoid air bubbles.)

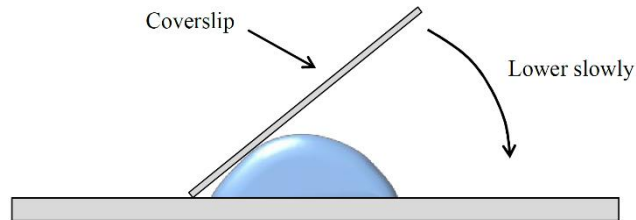
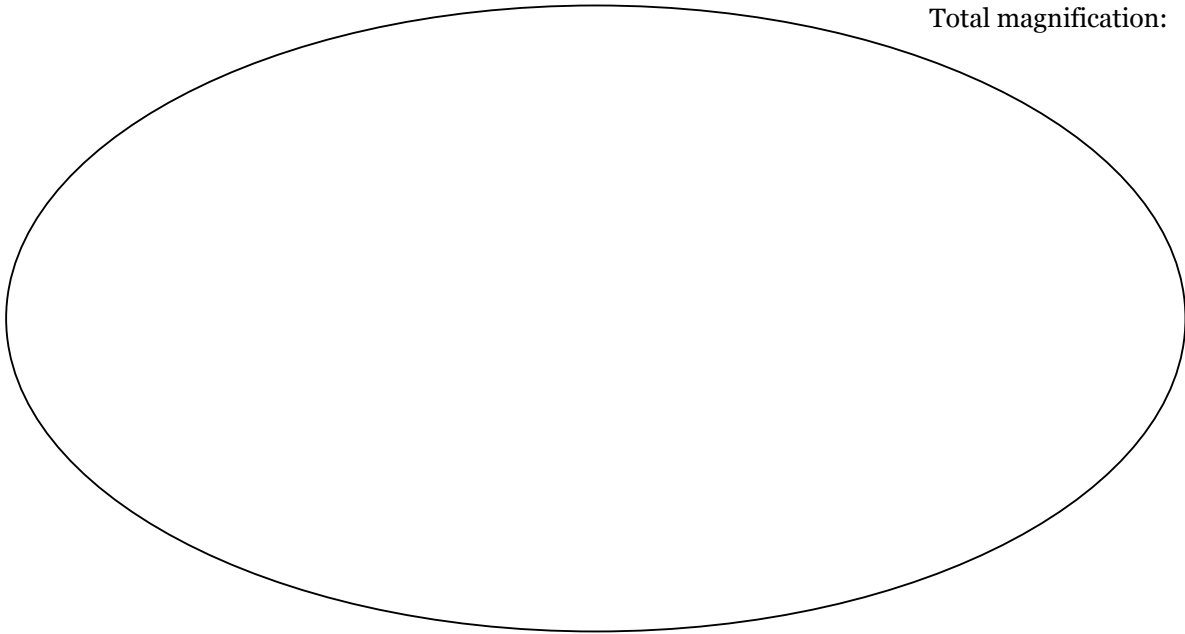

Figure of wet mount setup from Petersen, J. and S. McLaughlin. 2016.

19. Draw several kinds of organisms in the pond water, with as much detail as you can see. Some examples are given in a figure. You do not need to identify the organisms. Labels are useful for repeating patterns, colors, movements, and textures.

Total magnification:



20. When you are done with your pond water observations, discard the cover slip in the broken glass container and clean the slide with soap and water. Dry the slide completely before returning it.
21. There may be a phase-contrast microscope set up for you to compare with your pond water observations.

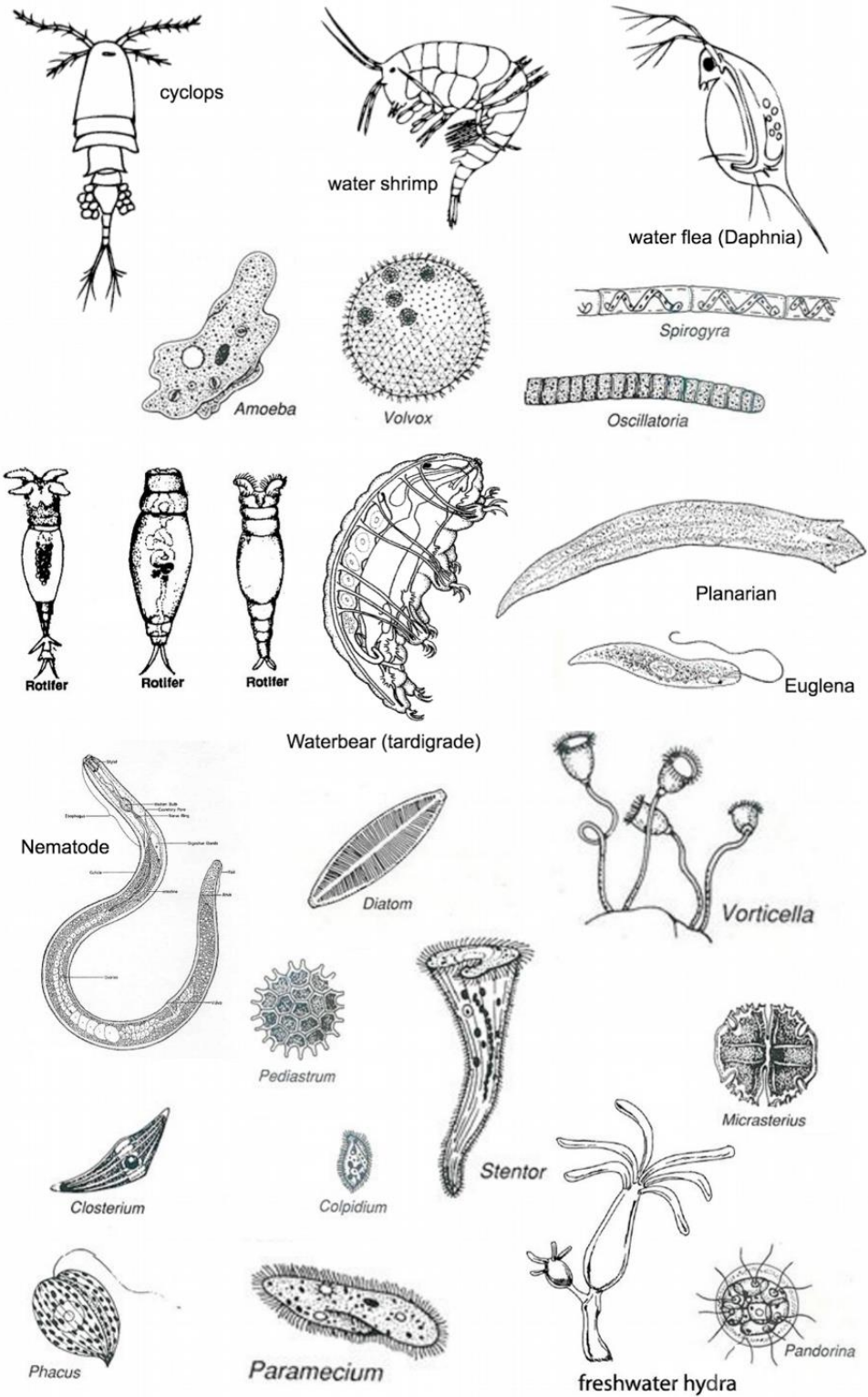

Image from M. Cuthbertson.

Observing bacterial cells under the microscope.

In this part of the exercise you will learn how to use the oil immersion lens, and observe some common morphologies and arrangements of bacteria.

1. Obtain a “three bacterial types” slide from the slide box and place it on your microscope. Since bacterial cells are very small, you will need to use the highest magnification (100X objective, or 1000X total magnification) to see them clearly—however, as with all slides, you should use a low-power objective lens to focus on the slide before moving to high power.

Note: The bacteria have several different shapes, and these shapes may be either mixed together, or separated on different areas of the slide.

The bacterial types slide may be viewed with all 4 objectives—alternatively, your instructor may ask you to skip some (for example, just use the 10X and 100X objectives). Follow the instructions you receive in class.

There are several areas of bacteria on the slide.

2. Focus with a low-power objective on the slide. The cells will still be very small at this magnification and you will not see any detail.
3. Once in focus, switch the objectives to 10X and then to 40X (this step may be skipped). Adjust light and focus as needed.
4. You are now ready to use the oil immersion lens. This lens requires the use of immersion oil, which has the same index of refraction as glass, to prevent light from scattering and focus it on your specimen (we need a lot of light to see clearly at this high magnification).

Immersion oil **MUST** be used with the 100X lens.

Immersion oil should **NEVER** be used with the high dry lens.

5. Rotate the nose-piece so that there is no objective over the stage. Add 1–2 drops of immersion oil to the slide right above where your sample is.

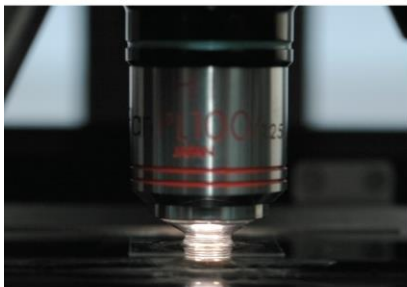

(a)

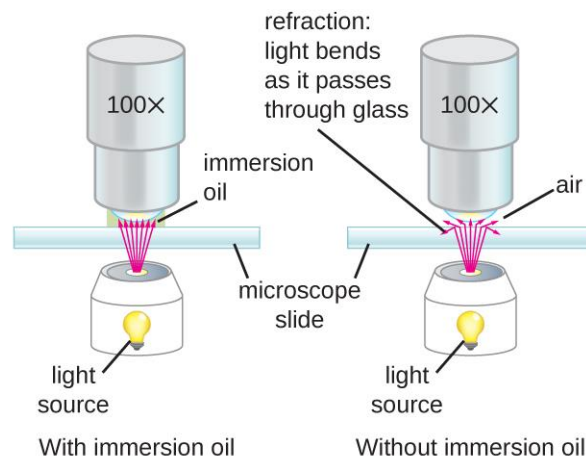

(b)

Image from Open Stax Microbiology.

6. Click the 100X objective into place. If done correctly, you should only need to fine focus a little bit to bring the cells into view.

Remember to NEVER use the coarse adjustment knob when focusing under 40X or 100X objectives.

If you “get lost,” it’s better (and faster) to go back to low power and refocus, and then switch back to the 100X objective.

Once there is oil on the slide you CANNOT use the 40X lens—rotate the nose-piece the other way to use 4X or 10X to refocus.

7. Use the spaces provided to draw the three types of cells on the slide. Again, labels are useful for repeating patterns and colors.

Bacilli / Rods

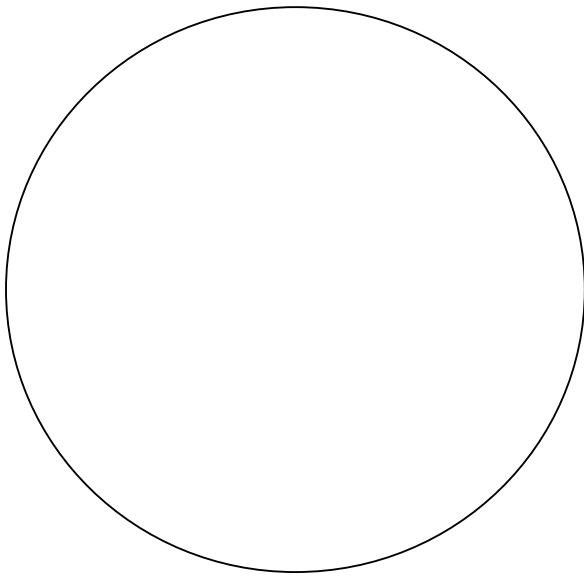

Cocci / Spheres

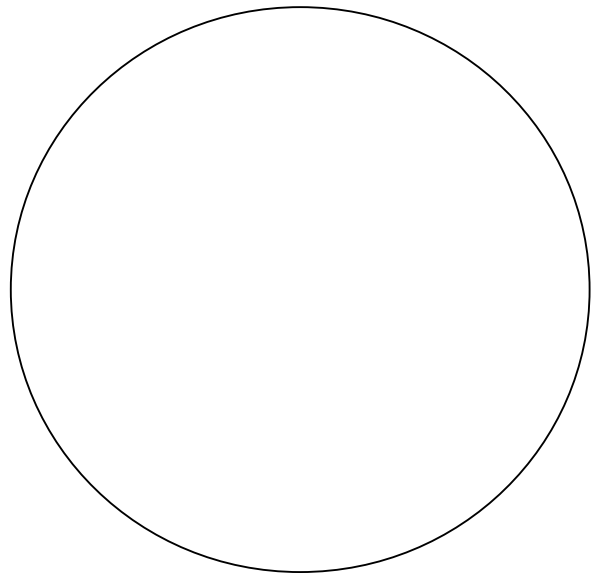

Spirilla / Spirals

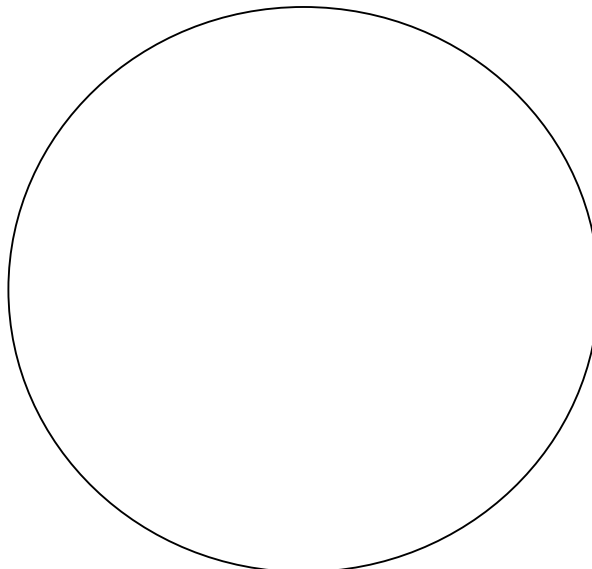

Cocci

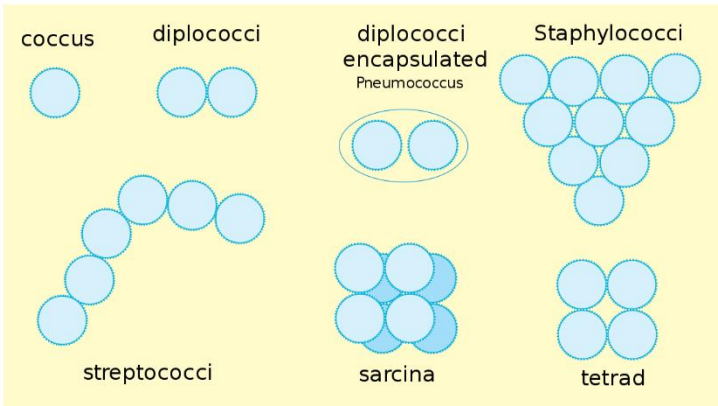

Others

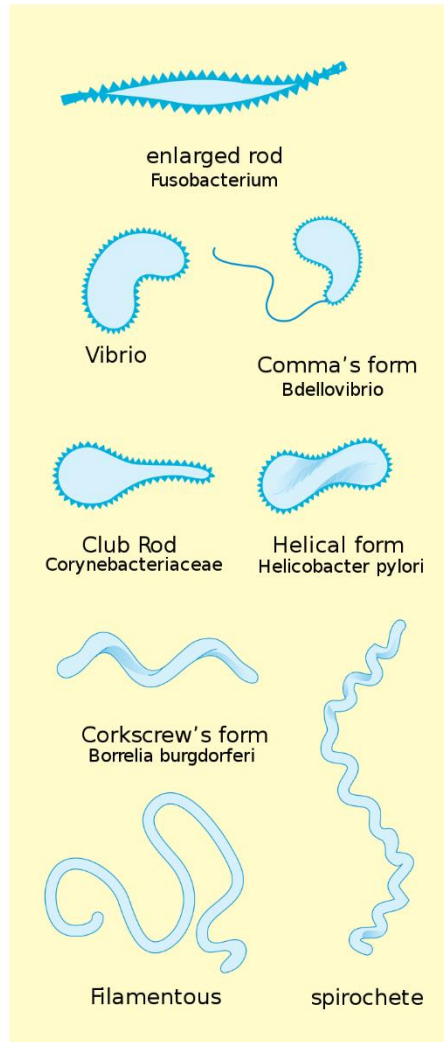

Bacilli

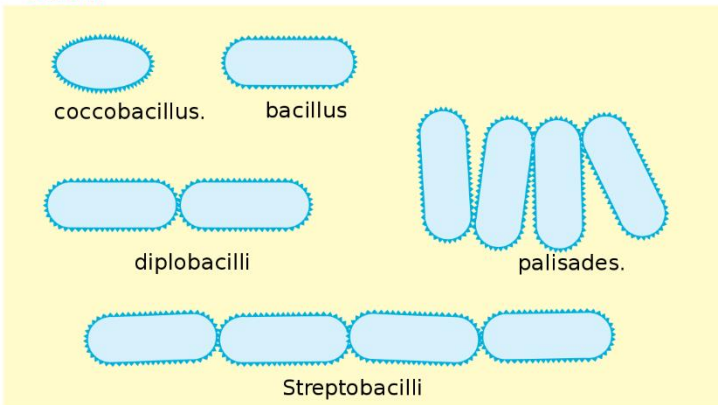

Budding and appendaged bacteria

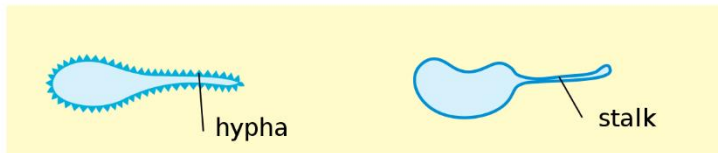

Note: A spirillum rotates rigidly along the long axis like a spinning corkscrew or drill bit, while a spirochete is flexible and undulates without spinning, due to axial filaments that are rotating inside.

Image from LadyofHats, Public domain, Wikipedia. 2006.

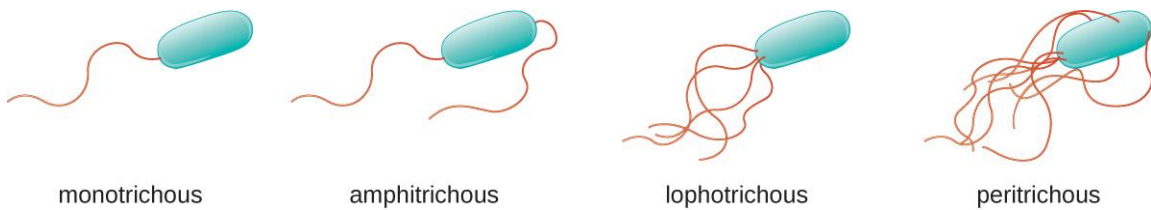

Flagella arrangements figure from Open Stax Microbiology.

8. Now examine the slides of these two bacterial species, and draw what you see.

Staphylococcus aureus

Escherichia coli

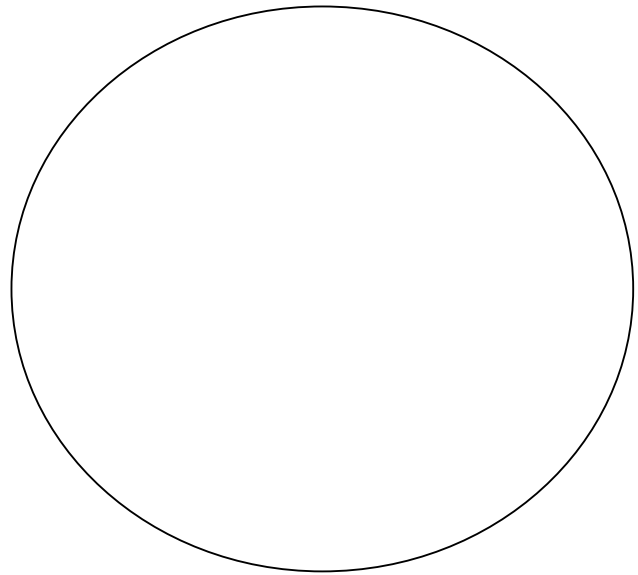
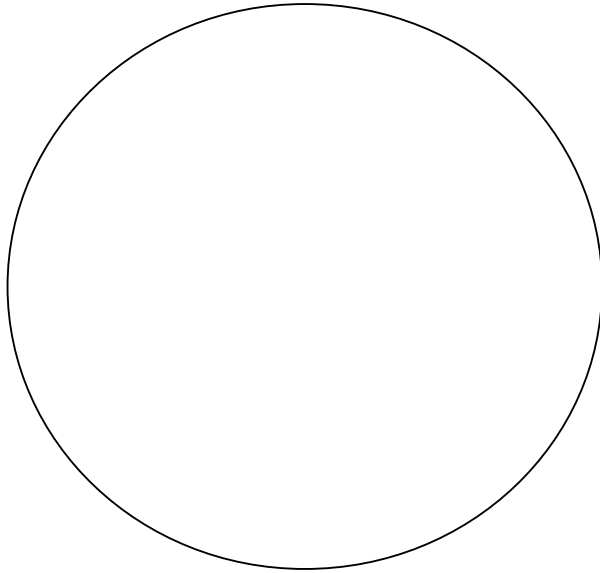

9. Find the *Proteus vulgaris* slide with the stained flagella. Draw what you can find. What kind of flagellar arrangement do these have?

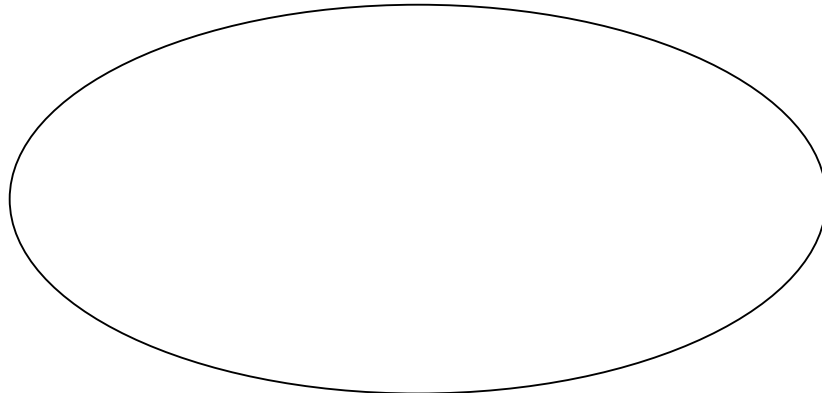

10. In order to observe bacterial movement, we need to use a living sample. Staining would help us see these translucent cells, but the stains usually kill bacteria. Observe the hanging-drop slide and sketch what you see. (This may be an instructor demonstration only.)

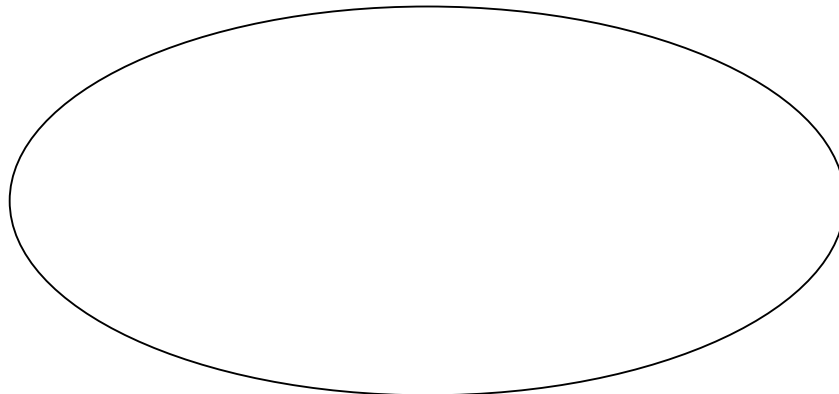

This is how a hanging-drop slide is prepared. Figure from Macedo, Wikimedia Commons, 2016.

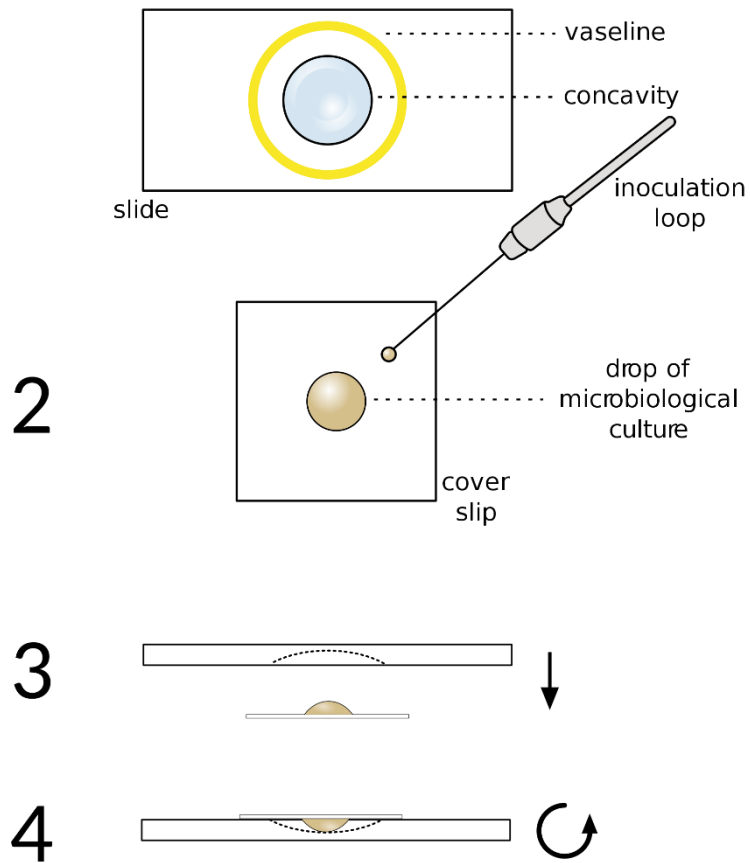

11. Which slide gives you more information, the hanging drop or the stained slide? Why do you say so?
12. Why might it be valuable to know whether a bacterium is motile?
13. Now we have a chance to observe bacteria from your body. These bacteria are called normal microbiota. Why are normal microbiota valuable?

14. Place a drop of methylene blue on a clean slide. Use the rounded end of a sterile toothpick to gently scrape around the base of your teeth in the gingival pockets, and transfer this sample to the drop of methylene blue. Place a cover slip on top. Discard the toothpick in the biohazard container. Sketch the bacteria you can find. Soak the slide in germicide for several minutes before cleaning.

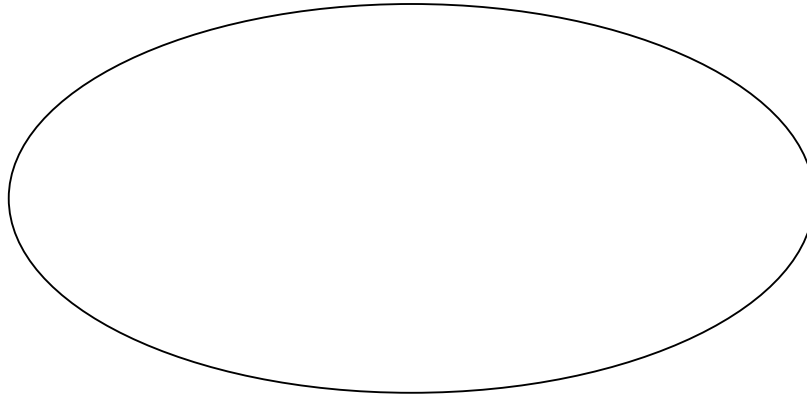

15. When bacteria have enough nutrients, they can multiply rapidly into millions of cells. These bacterial colonies are visible without a microscope. Observe the colonies growing on nutrient agar in the Petri plates, and draw several of these colonies.

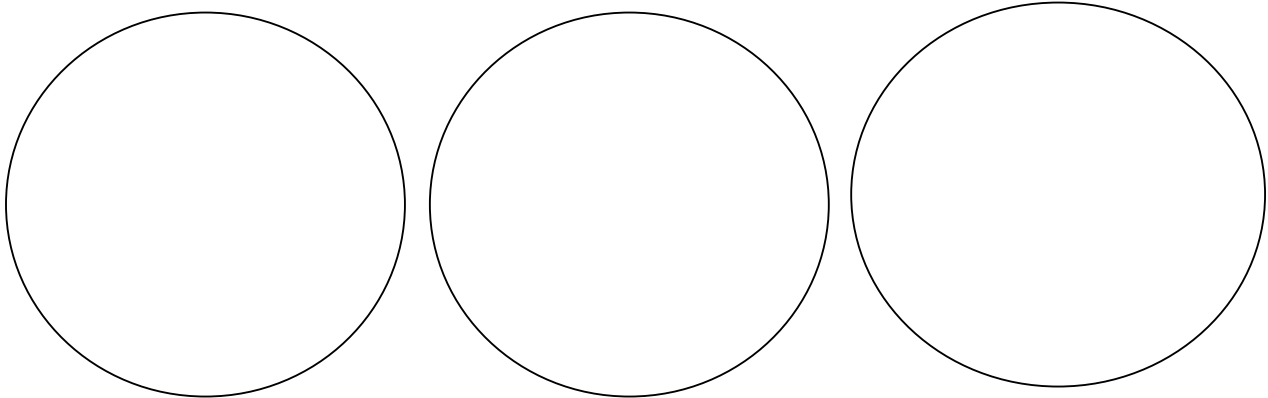

16. For optional practice, you may observe these additional slides. Feel free to compare your observations with the figures in the *Photographic Atlas*.

Mycobacterium tuberculosis: Causes tuberculosis. Bacillus. Clumped together or in cords.

Corynebacterium diphtheriae: Causes diphtheria. Irregular / pleomorphic bacilli, some with club-shaped ends.

Clostridium tetani: Causes tetanus. Long bacilli with terminal spores.

Klebsiella pneumoniae: Causes a severe pneumonia and other diseases. Bacillus, surrounded by a protective capsule.

17. When you are finished, clean all oil off of the slides and return them to their slide boxes.

Checklist for putting the microscope away:

- Dim the lamp and turn it off.
- Hold the very end of the plug when unplugging.
- Remove immersion oil with lens paper, checking all lenses and the stage. (Slides may be cleaned with Kim-wipes, but lenses are to be cleaned only with lens paper. Any other material will scratch the lenses.)
- Turn the 4x objective into position to leave lots of room above the stage.
- Wind up the cord.
- Sign out on the sheet in the front of lab.

Additional review questions:

1. What is the function of immersion oil?
2. Which is the only lens that should touch immersion oil?
3. Why do you think water **wouldn't** work in place of immersion oil?

4. What happens to the size of the field of view as you increase magnification?

5. How does the working distance change as you increase magnification?

6. Which focus knobs can you use to focus each of these objectives?

Scanning:

Low power:

High power:

Oil immersion:

7. Why do we start with the low power lens when looking at a new slide?

8. Define resolution.

9. What is the function of the iris diaphragm?

10. When should microscope lenses be cleaned?

11. How do we clean microscope lenses?

12. Your friend in class is having trouble focusing their microscope. What are some things you could recommend that they check?

13. Why is it important that health care professionals know about microorganisms?

14. What is the main difference between prokaryotic and eukaryotic cells?

15. Why is it important to use immersion oil when using the 100X objective?

16. Are there things that are too small to be seen with a light microscope? Explain.

17. Of the organisms you have looked at today, which are unicellular and which are multicellular?

Unicellular:

Multicellular:

18. Fill in the blanks, with “increases” or “decreases”: As magnification increases, the area of the field of view _____, the depth of the field of view _____, the working distance _____, and the amount of light required _____.

19. Distinguish between morphology and arrangement.

20. What do you think would happen if you tried to view a slide using the oil immersion lens but forgot to add the oil?

Name _____ Date _____

Section # _____

Part 2: Handling, Growing, and Simple Staining Bacteria

Exercise 2: Culturing your Environment

Objectives

- Learn to define terms related to this lab.
- Demonstrate aseptic techniques and laboratory procedures.
- Describe colony characteristics.
- Compare bacterial growth from various sources.
- Describe the value of agar in culture media.

Introduction

Before coming to lab, define these terms:

- Culture medium / media:
- Inoculum:
- Microbial culture:
- Sterile medium:
- Agar (note: this is not a nutrient):
- Agar liquefies/melts at this temperature:
- Agar solidifies/freezes at this temperature¹:
- Agar slant:
- Agar deep:
- Petri dish / Petri plate:

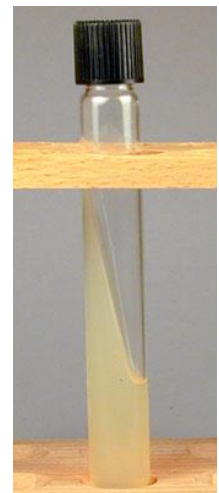

Figure of slant tube from G. E. Kaiser. 2017.

¹ This is special because most materials liquefy and solidify at the same temperature. For example, water both melts **and** freezes at 0°C.

- Chemically-defined media:
- Complex media:
- Nutrient broth:
- Nutrient agar:
- Fastidious organism:
- Selective media:
- Differential media:
- Enrichment media:

Materials (per student):

- 5 petri dishes
- 5 melted deeps of T-soy agar*
- 8 sterile cotton swabs

* T-soy is Tryptic soy agar. Many microorganisms can grow on it. T-soy contains tryptone, soytone, sodium chloride (salt), and agar (to make it solid at room temperature). The mixture is poured into tubes and sterilized in an autoclave at 121°C for 15 minutes. The agar can be kept hot to keep it liquid, or be allowed to cool into deeps or slants.

How to pour petri plates from deeps:

1. Remove cap of tube.

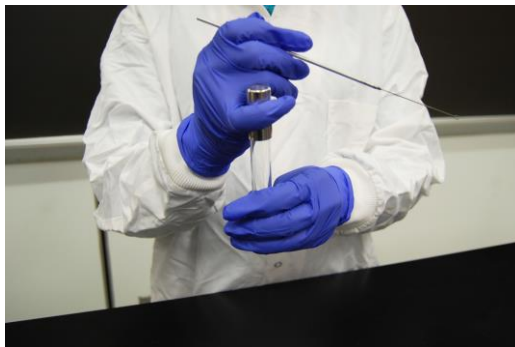

Figure from G. E. Kaiser. 2017.

2. Hold opening of tube at Bacticerator for a few seconds.
3. Pour entire tube into bottom of empty dish (not into the lid!).
4. Gently swirl the dish to spread the agar across the bottom.



Figure from G. E. Kaiser, 2017.

Bacticerator instructions:

1. A light will come on when the switch is in the "ON" position.
2. Once the unit is switched on, wait approximately 10 minutes for the optimal sterilizing temperature (1500°F / 816°C) to be reached.
3. Gently insert the loop or needle, attached to an insulated loop holder, into the Heater Element. DO NOT scrape the sides of the Heater Element. Scraping the sides of the Heater Element will reduce the life of the unit. Insert the loop toward the rear of the heating element to avoid spattering. The loop should remain within the heater element a minimum of five seconds. It is not necessary to obtain a glowing loop to ensure sterility. NOTE: All the demonstrable microorganisms will be destroyed within five seconds.
4. Precautions and Maintenance:
 - Only insulated loop holders should be used when inserting inoculating loops or needles into the heater element.
 - DO NOT use for scalpels, forceps or any sharp objects. The use of such objects can cause element malfunction and void the heater element warranty.
 - Periodic visual inspection of the heater element should be performed to determine if the heater element core is worn. Inspect for small cracks and residue buildup in both the cool and heated conditions. NOTE: In the heated condition, cracks can be seen as small, intensely yellow-orange fissures. If any defects are noted, the heater element should be replaced before element malfunction occurs.
 - DO NOT allow the inoculating loops and needles to stay in the heater element for extended periods of time. This causes the loop holder to become extremely hot and increase the wearing of the loops and needles.
 - The cooling shield can reach temperatures of up to 400°F. Avoid contact with flammable materials.
 - Use unit in accordance with these operating instructions, as protection provided by the equipment may be impaired if instructions are not followed.

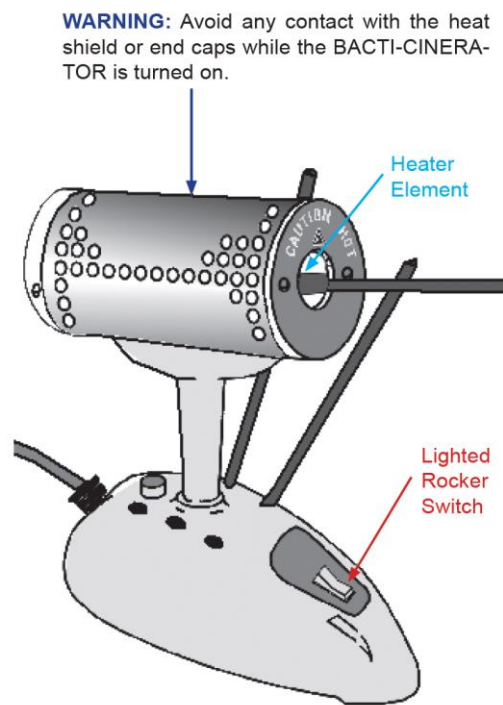

Figure of Bacti-Cinerator from Electron Microscopy Sciences.

Bacti-Cinerator Instructions quoted from Electron Microscopy Sciences.

Procedures for making cultures from your environment:

1. Make five petri plates for yourself. (You may want to take just one or two melted deeps at first, so that they don't solidify before you have a chance to pour them.)
2. Allow the plates to cool for about ten minutes.
3. Mark on the bottom of the plates to divide them. Divide four plates in half, and divide the fifth plate into quarters for your handwashing experiment.
4. Label the bottom of the plates with your name, date, lab time, and eventually indicate the source of each specimen (for example, your shoe).
5. Use sterile swabs to inoculate your 8 half-plates with organisms from unusual places. Be creative! Some creative sources are the trash cans, your phone, up your nose, between your toes, in your belly button, under your armpit, in the bathroom... You can try testing food samples before and after they hit the floor (so long as you discard them after bringing them into lab). You may even bring items from home to test, such as your toothbrush or a kitchen sponge. **Tip:** For dry surfaces, get the swab wet first, using the sterile condensation inside the plate lid.
6. Discard all swabs in the Biohazard waste container / burn box.
7. Use the fifth plate to test your handwashing technique. One method is to touch the first and second quadrants with your unwashed thumbs, then wash your hands, and then touch the third and fourth quadrants with your washed thumbs. You are welcome to use variations.
8. Store your plates upside-down in the assigned incubator until the next lab.

Next lab:

These terms are used to describe bacterial colonies. The “margin” is the edge of the colony.

Form

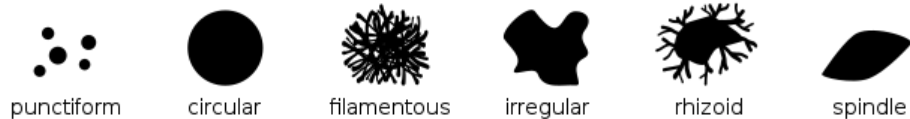

Elevation



Margin



Image from Macedo. 2016. Wikimedia Commons. Accessed 2018.

Observe your plates and record your results. Make note of colony sizes, numbers, colors, forms, margins, and elevations. Also note whether the growth is relatively light, moderate, or heavy compared with your other samples.

Plate incubated at _____ °C for _____ days.

Environmental source 1:

Environmental source 2:

Colony descriptions

Colony descriptions:

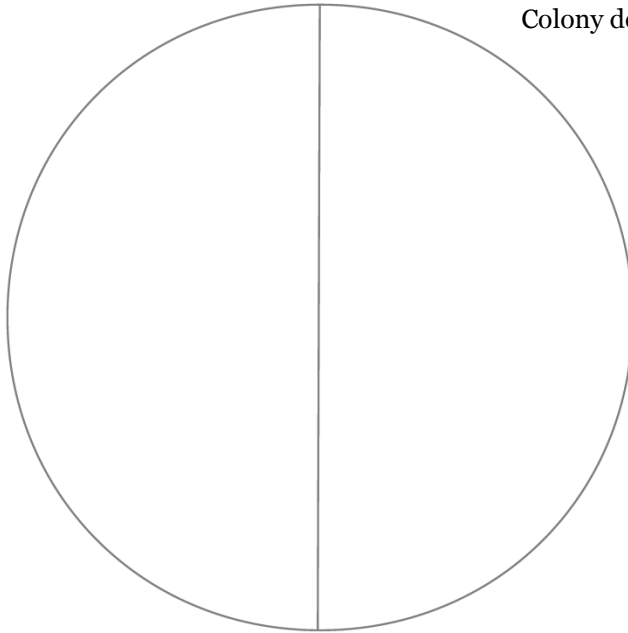

Plate incubated at _____ °C for _____ days.

Environmental source 3:

Environmental source 4:

Colony descriptions:

Colony descriptions:

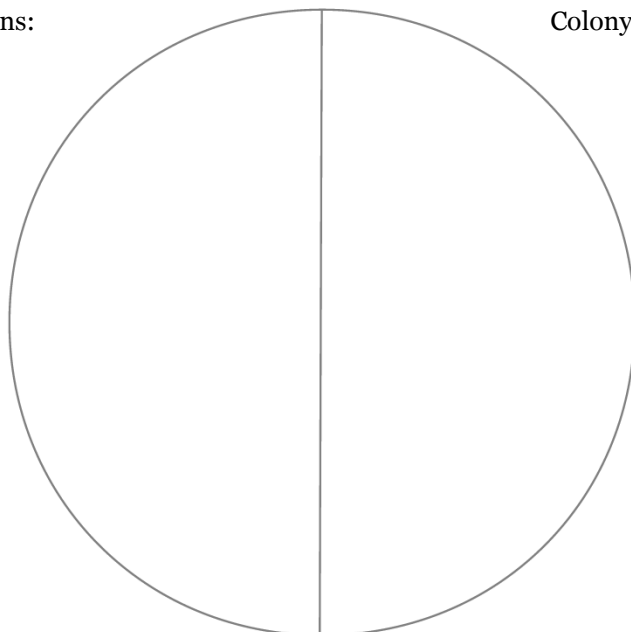

Plate incubated at _____ °C for _____ days.

Environmental source 5:

Environmental source 6:

Colony descriptions:

Colony descriptions:

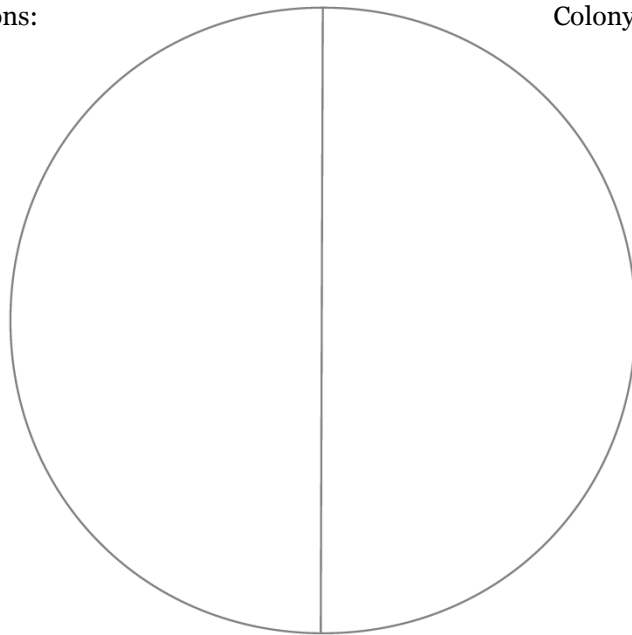

Plate incubated at _____ °C for _____ days.

Environmental source 7:

Environmental source 8:

Colony descriptions:

Colony descriptions:

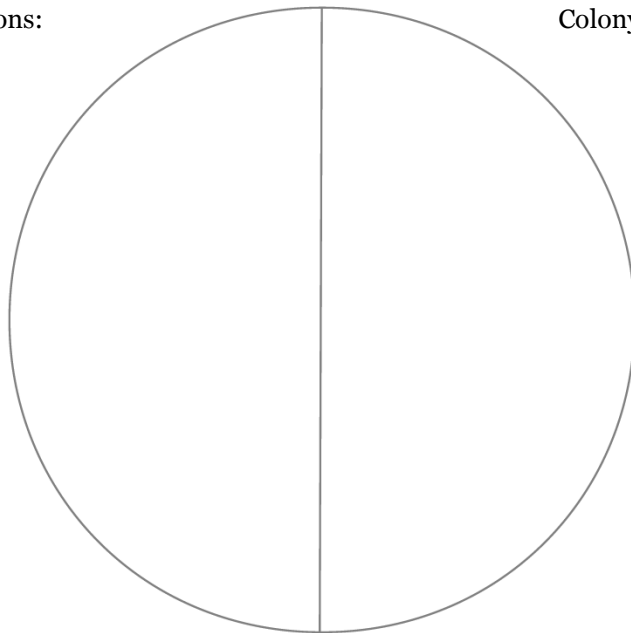

Handwashing plate:

Plate incubated at _____ °C for _____ days.

Source:

Colony descriptions:

Source:

Colony descriptions:

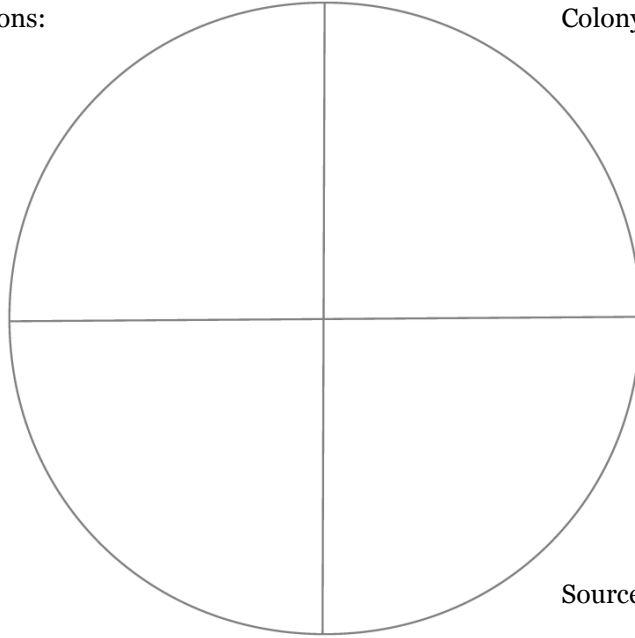

Source:

Colony descriptions:

Source:

Colony descriptions:

Store your plates back in the assigned incubator. You may be able to stain some of the most interesting organisms in a future lab.

Review questions

1. Which environmental sample had the largest number of colonies? Why do you think this happened?

2. Which environmental sample had the least growth? Why do you think this happened?

3. What did you learn about your handwashing technique? Did you expect these results? Why or why not?

4. What is the benefit of washing hands, if they are not sterile afterwards?

5. What is a bacterial colony?

6. Which T-soy ingredients are the bacteria using for nutrients?

7. Which T-soy ingredient is probably **not** being used by bacteria?¹

8. What is the purpose of the agar?

9. Why is agar used, instead of gelatin or starch?

¹ Some marine microorganisms **can** break this down, though, which makes sense.

10. Why do incubators in clinical labs usually operate at 35-37°C?
11. If one of your environmental sources produced no growth, does this mean that the area you swabbed was sterile? Explain.
12. Why are petri plates incubated upside-down?

Name _____

Date _____

Section # _____

Exercise 3: Media and Aseptic Techniques

Objectives

- Learn aseptic technique.
- Learn to sterilize inoculating instruments with a BactiCinerator.
- Describe bacterial growth in slants and broths.

Tip: To avoid fogging inside your goggles, try rubbing any of the following materials on the inside surface, and then letting it dry: mild dish soap, baby shampoo, non-abrasive toothpaste, or shaving cream.

Introduction to aseptic technique

Microorganisms are moved from one medium to another through subculturing. However, because microorganisms are already present in the air and on most surfaces, it can be difficult to move just a single kind of bacteria. Aseptic techniques are used to prevent contamination of the sample.

Essential steps:

1. Sterilize the inoculating needle or loop by inserting the wire into a hot Bacti-Cinerator for five seconds. (Do not leave the loop or needle in the Bacti-Cinerator because the handle will get very hot, and the pressure may crack the heating element.)
2. Once the cap of a tube is removed, airborne microorganisms can fall into the tube and into the cap. To minimize this contamination, do not set the cap down. Hold the open tube at an angle to reduce the amount of area for a microorganism to fall into. Do not leave the tube open for any longer than necessary.
3. Hold the opening of the tube at the mouth of the Bacti-Cinerator for five seconds. This mild heating of the test tube creates an air current that can help prevent airborne organisms from falling into the open tube.
4. (a) If working with a broth, gently swirl the original culture to suspend any particulate matter. Insert the sterile loop into the stock culture, and dip the loop of organisms into the new tube.
(b) If working with a slant, gently touch the surface of the growth with the loop. Inoculate the new tube by gently dragging the loop over the agar surface in a zig-zag line.
5. Before closing a tube again, hold the opening of the tube at the Bacti-Cinerator.
6. Sterilize the inoculating needle or loop again.

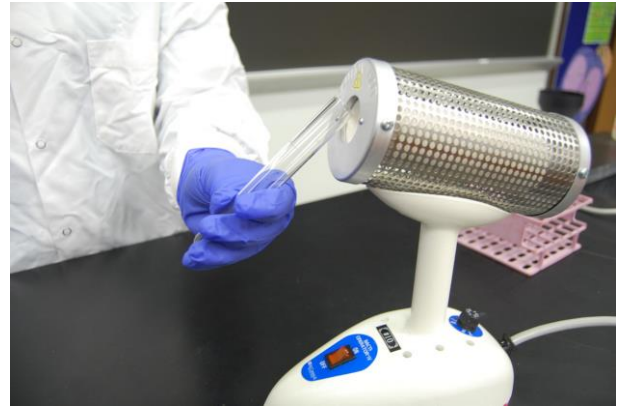
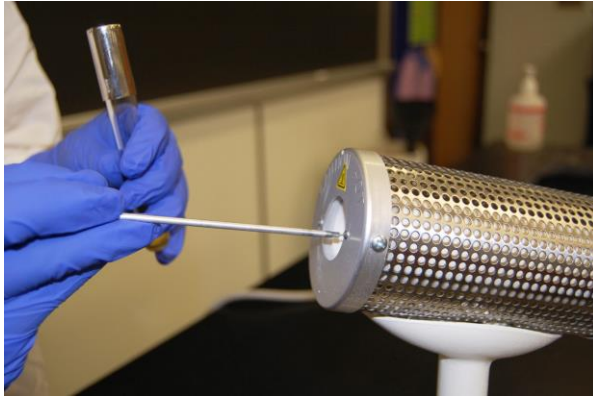

Images of instrument being sterilized, and tube edge being heated. From G. E. Kaiser. 2017.

Note: It is possible to hold two caps in one hand, but it is usually easier to work with just one tube at a time.

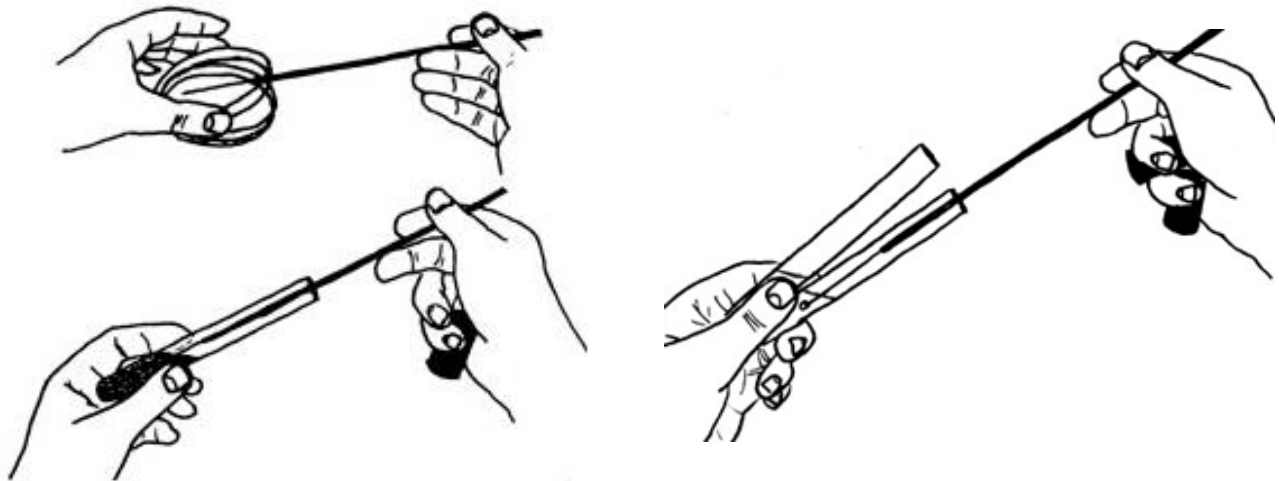
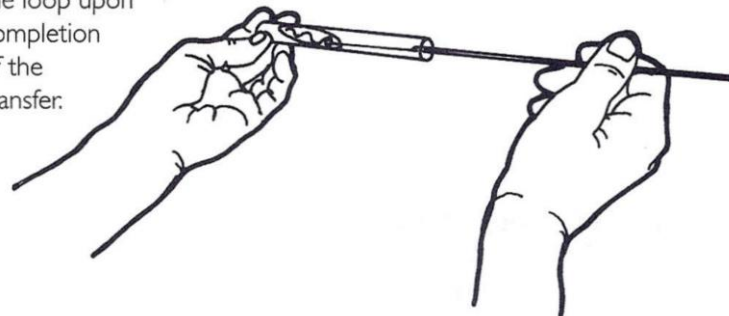

Figure showing how to hold plate lid and tube so that contaminants do not fall into the open containers. Second figure showing how to hold two open tubes at once. Image from J. Lindquist.

Agar slant inoculation:

Begin at the base of the slant surface and gently move the loop back and forth as you withdraw the tube. Be careful not to cut the agar. Sterilize the loop upon completion of the transfer.



Agar slant inoculation figure from M. J. LeBoffe and B. E. Pierce. 2011.

Peer assessment checklist:

Name of student performing steps: _____

Name of observer: _____

Date and time: _____

Have a friend in class observe your technique and complete this checklist for you:

- Upon entering lab, hands are washed for long enough to sing the “Happy Birthday” song twice.
- Lab coat, goggles, and gloves are worn.
- Lab bench is clear of unrelated materials (such as phones).
- Lab table is disinfected before experiment.
- Bactincinerator is warmed up for at least ten minutes.
- Inoculating loop or needle is sterilized.
- Any open tube is held at an angle.
- Any cap is held in the hand when removed.
- Any open tube is held at the Bacti-Cinerator.
- Lab table is disinfected after experiment.
- Before leaving lab, hands are washed for long enough to sing the “Happy Birthday” song twice.

Materials, per student:

- 3 sterile T-soy agar slants
- 3 sterile T-soy broths
- 1 tube of sterile water
- 1 sterile swab

Cultures provided for table:

- *Serratia marcescens* on a T-soy slant (“sir-A-shuh mar-CESS-ens”)
- *Serratia marcescens* in a T-soy broth
- *Staphylococcus aureus* on a T-soy slant (“STAH-fih-low-cock-us AW-ree-us”)
- *Staphylococcus aureus* in a T-soy broth

Instructions:

1. Label your tubes with your name, date, lab time, and the organism each tube will contain. (Write only on the clear glass, not on the lid or the white patch.)
2. Check for cloudiness or growth in the media.
3. Check that the inoculating loop handle is tightly screwed.
4. Use a loop to transfer *Serratia marcescens* from the agar slant to a new slant.
5. Use a loop to transfer *Serratia marcescens* from the broth to a new broth.
6. Use a loop to transfer *Staphylococcus aureus* from the agar slant to a new slant.
7. Use a loop to transfer *Staphylococcus aureus* from the broth to a new broth.
8. Use a loop to transfer sterile water into your last sterile broth.
9. Dip a sterile swab into your sterile water and streak this onto your last slant. Dispose of the swab in the biohazard container.
10. Place your tubes in a plastic beaker and store in the assigned incubator. (A beaker can hold tubes from two students.)

Next lab:

Examine your tubes and record your results. Do not discard your tubes at the end of lab. Store them back in their beaker, because they will be used again for simple staining.

Any turbidity (cloudiness) means that you have growth in the tube. The figure shows some common growth patterns in broths.

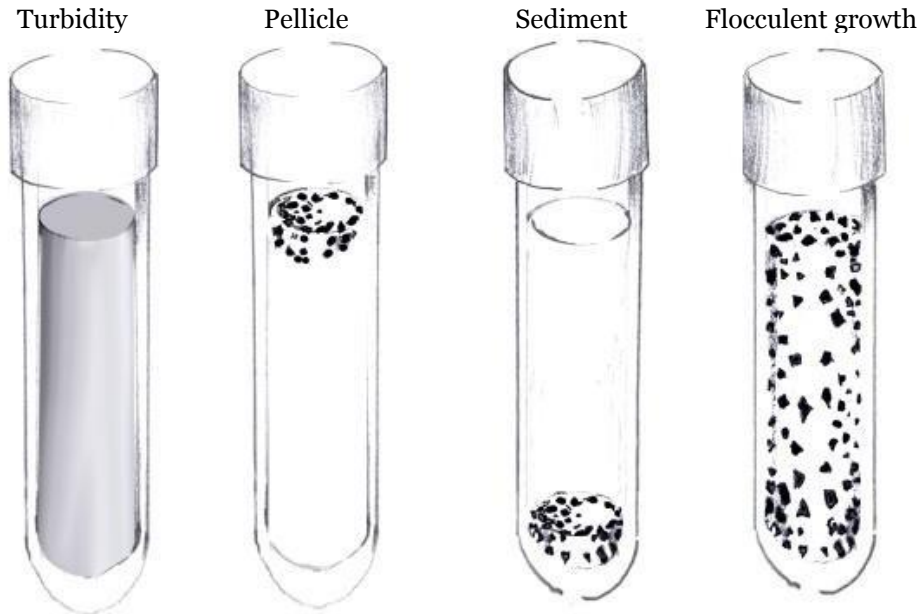

Figure from Petersen, J. and S. McLaughlin. 2016.

Broths: Include colors and broth terms.

Serratia marcescens broth



Staphylococcus aureus broth



Sterile water in broth



This figure shows some common growth patterns on slants.

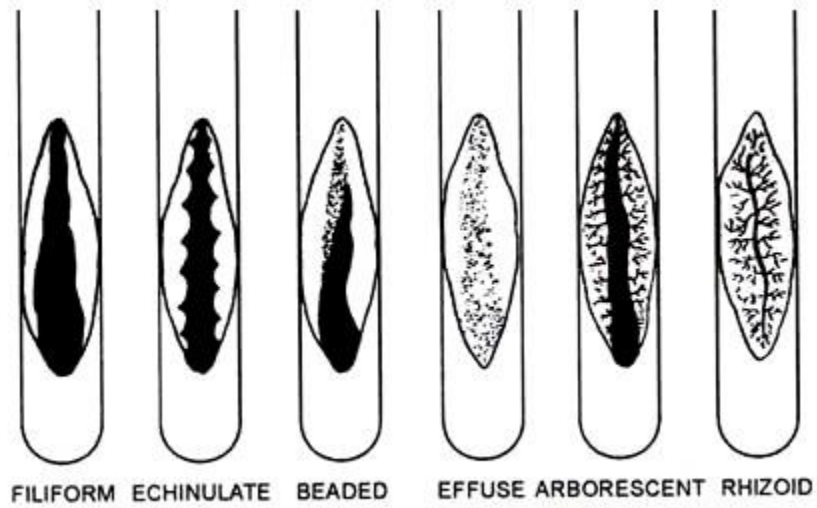

Figure from Shreeja D. Soil Management India. Accessed 2018.

Slants: Include colors, slant terms, and consistency (such as dry, buttery, moist, shiny, slimy, glistening, etc.).

Serratia marcescens slant

Staphylococcus aureus slant

Sterile water swabbed on slant

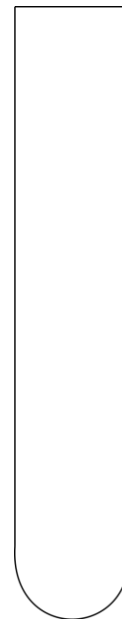

Review questions

1. Can you distinguish the *Serratia marcescens* broth from the *Staphylococcus aureus* broth? Were these results expected? Why or why not?
2. If you see growth in the broth that was inoculated with sterile water, what are some possible sources of contamination?
3. If you wanted to find out whether a broth contained a mixture of species or a single species, how could you do this?
4. Can you distinguish the *Serratia marcescens* slant from the *Staphylococcus aureus* slant? Were these results expected? Why or why not?
5. How can you tell if any of your slants were contaminated by other organisms?
6. Which media provides more information, the slant or the broth? Explain.

7. How can you determine whether media are sterile before you use them?

8. Why do we disinfect the lab bench before working with bacterial cultures?

9. Why is the opening of a tube held at the Bacti-Cinerator before and after transfers?

10. Why are open tubes held in a nearly-horizontal position, rather than vertically?

Name _____

Date _____

Section # _____

Exercise 4: Simple Stains

Objectives

- Learn to clean and label a slide for a bacterial smear.
- Learn to prepare smears from liquid and solid media.
- Compare the shapes and arrangements of bacterial cells.

Materials

- Glass slides (at least three)
- Wax pencil
- Broth and slant cultures of *Serratia marcescens* and *Staphylococcus aureus*, and environmental sources
- Bacteriocide
- Stains
- Stain waste beaker
- Bibulous paper

Instructions

Make smears of your *Serratia*, *Staphylococcus*, and at least three interesting environmental organisms. Observe your smears under oil immersion, and note your observations.

Diagram of slides:

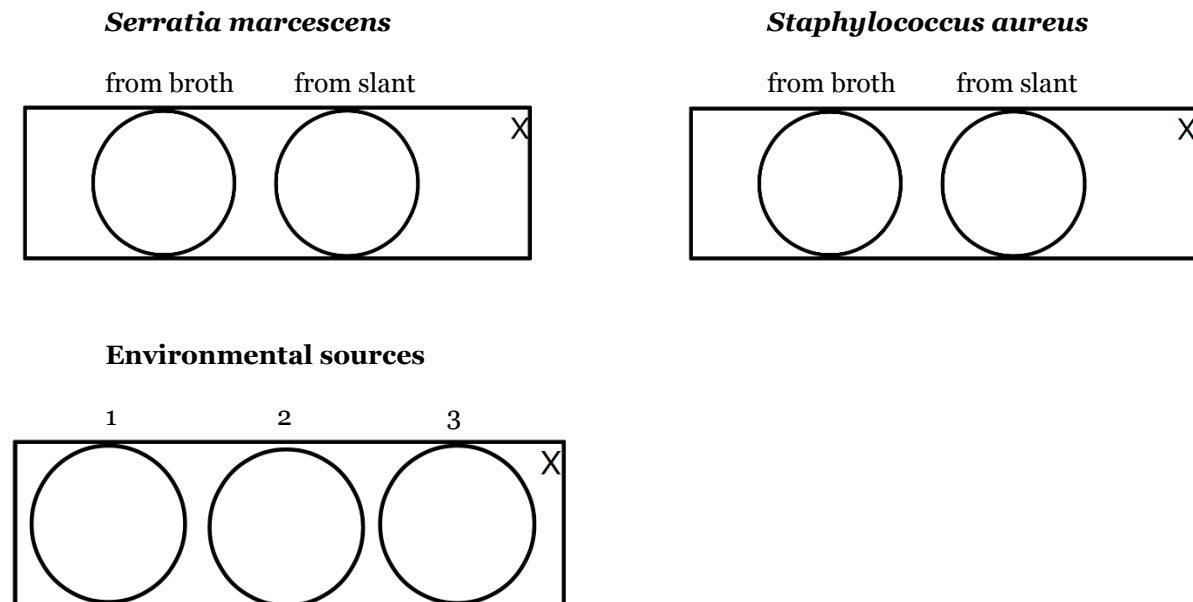

How to make a smear:

1. Clean a glass slide by washing it with soap and water. If any residual stains or waxes are visible on the glass, wash it again. (Oils can prevent your smear from adhering to the glass. Old stains can make it difficult to distinguish your organisms from earlier smears.)
2. Make a wax pencil mark in the upper right-hand corner of the slide. This will be a useful reference point, so that you can later determine whether your smear is on top of the glass, or is underneath. (This is an issue because the oil objective must be very close to your smear in order to be in focus. If the slide is upside-down, the oil objective will never get close enough, and you will not get a focused image.)
3. Label your slide with your initials and some indication of which bacteria the slide will hold.
4. Sometimes it is helpful to draw a circle where you intend to place bacteria, to make it easier to find them later.
5. If your bacteria are coming from a broth: Dip a sterile loop into the broth, and drag the loop over the glass, spreading the liquid. The more you spread the liquid, the more efficiently it will dry.

If your bacteria are coming from a slant: Place a loop of water on the slide – not a drop, but a loop. (If there is sterile water available, using it can reduce the chance that you include contaminants in your

smear.) Use a sterile loop to barely tap onto the surface of the slant growth, and drag the loop through the water on the slide.

6. Wait for the slide to dry completely.

Note: The best way to reduce this drying time is to use tiny amounts of liquid, and then to spread the liquid as much as possible across the glass. If you have large amounts of liquid on the glass, it can easily take more than 30 minutes to dry!

Warning: It may be tempting to hold the wet smear over the hot Bacti-Cinerator to speed the drying process, but this will not help. The bacterial cells will get cooked by the hot water, and the cells will look as though they are fused together.

7. Once your slide looks dry, wait another few minutes to be sure.
8. Don't panic. A good smear is often invisible at this point, or may look like a thin whitish layer or pale film. You should be able to read a printed page through the smear. If the smear is too thick, piles of cells will make it difficult to see the shape of individual cells. One strategy for dealing with too-thick smears is to look at the edge of the slide, where cells may be more spread out.
9. Heat-fix your slide by holding it directly above the Bacti-Cinerator for five seconds. Use a slide-holder to prevent burns. Heat-fixing helps make the bacteria adhere to the glass.



Figure of heat-fixing method from D. Cain. 2016. Collin College Microbiology. Accessed 2018.

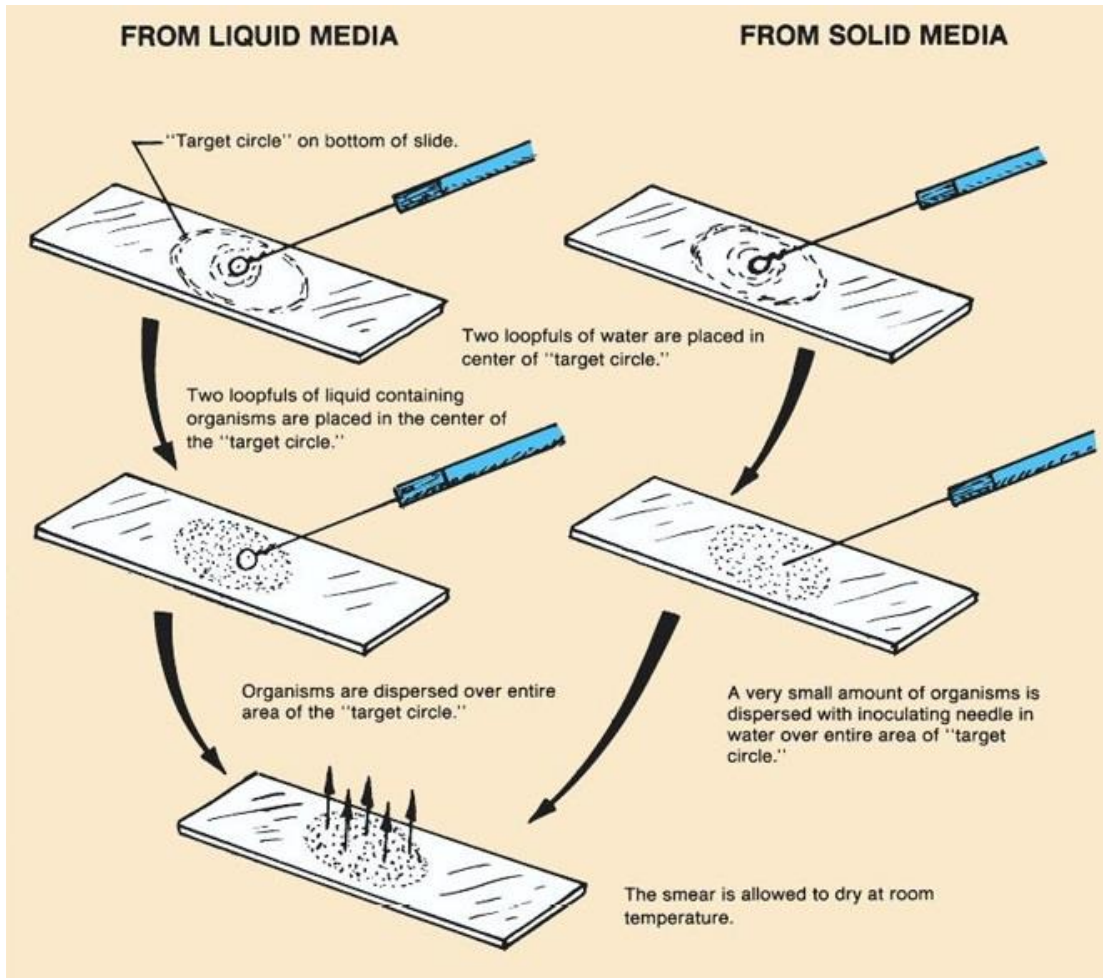

Figure of smear method from Microscope Science. Microscope Slide Techniques. Accessed 2018.

Stain your smear:

1. Dip your slide into stain for one minute. Crystal violet, methylene blue, and safranin are available for simple stains.
2. Remove the slide from the stain container, and hold it over a stain-waste beaker.
3. Use the squeeze-bottle of water to gently rinse your slide, until the water runs off clear.
4. Gently blot your slide dry in bibulous paper.

Observe your smears:

1. Stained smears do not require a cover slip. When you use the oil immersion lens, just place a drop of oil directly onto the smear.
2. When you are done viewing a smear, gently dab off the oil with a Kimwipe or lens paper.

Results

Draw diagrams of the smears you made.

***Serratia marcescens* from broth**

Total magnification: 1000x

Morphology:

Cell arrangement(s):

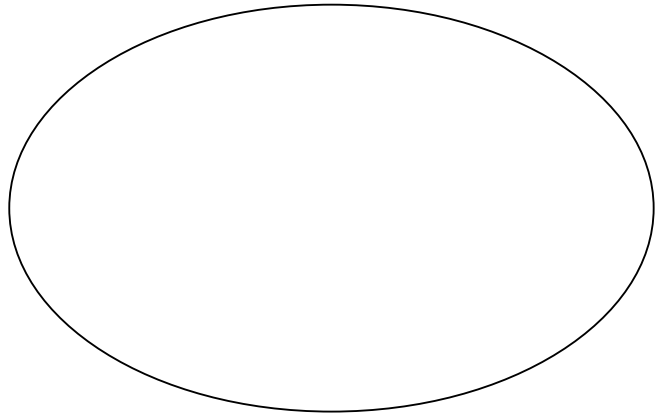

***Serratia marcescens* from slant**

Total magnification: 1000x

Morphology:

Cell arrangement(s):

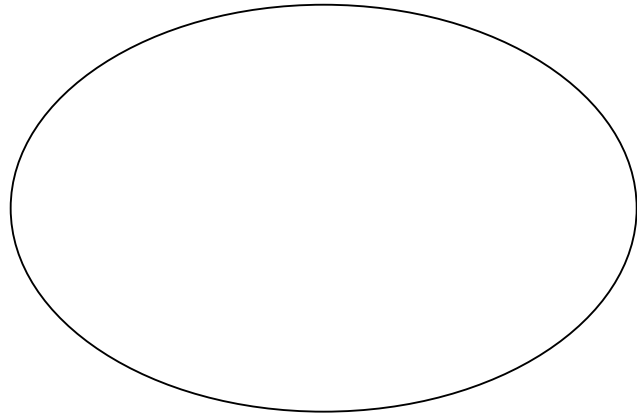

***Staphylococcus aureus* from broth**

Total magnification: 1000x

Morphology:

Cell arrangement(s):

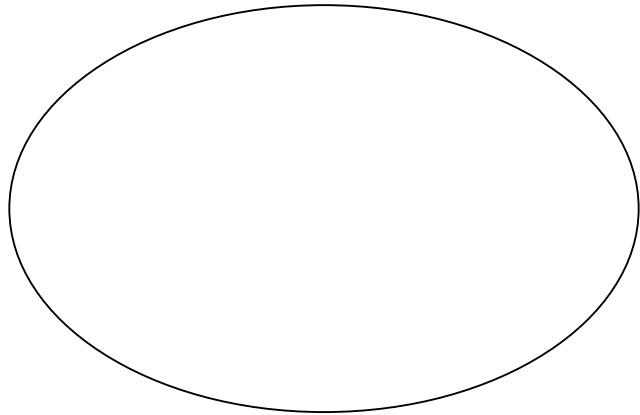

***Staphylococcus aureus* from slant**

Total magnification: 1000x

Morphology:

Cell arrangement(s):

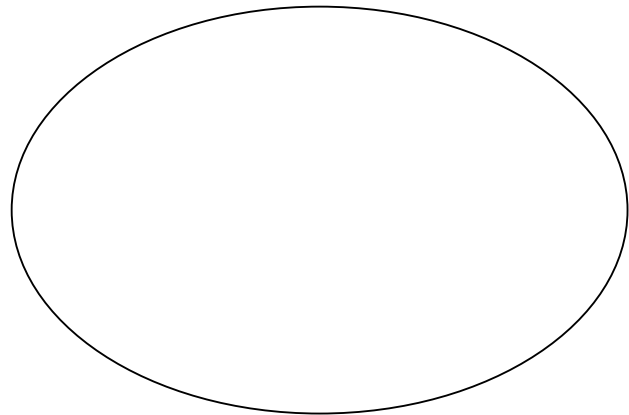

Environmental cultures

Make smears of as many colonies from your environmental plates as time allows. Record your observations of at least three here.

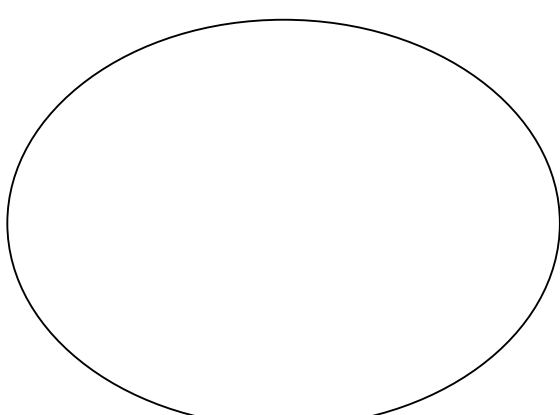
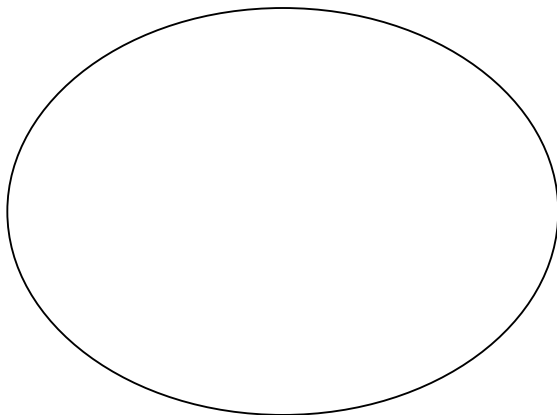
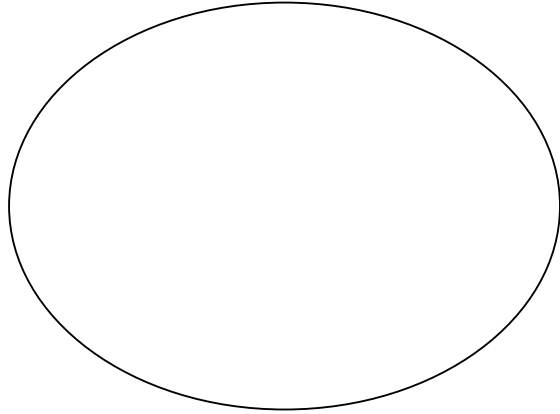
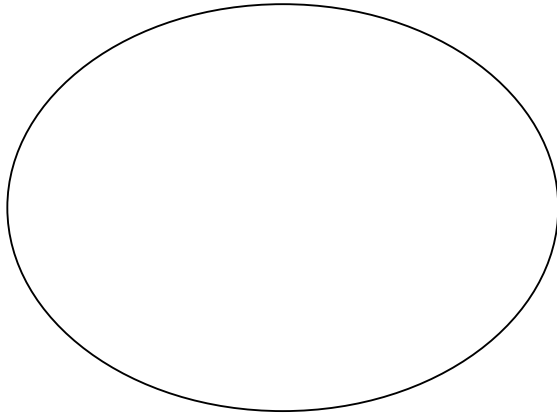

Disposal / Clean-up:

1. Clean all slides. (A drop of acid-alcohol or ethanol works well, along with a dry paper towel. Soap and water also work well. Dry all slides completely before returning them.)
2. Discard culture tubes and petri plates.
3. Empty stain-waste beakers into sink, and rinse them with water.
4. Clean microscope.

Review Questions

1. How are the two smears of *Serratia marcescens* different from each other?
2. How are the two smears of *Staphylococcus aureus* different from each other?
3. What is the purpose of simple staining?
4. Why are thick smears harder to observe under a microscope?
5. Why must smears be air-dried, rather than dried over the Bactincinerator?
6. Why is it important not to overheat the smear during heat-fixing?

Name _____

Date _____

Section # _____

Part 3: Differential and Structural Staining

Exercise 5: Gram Stain, Acid-Fast Stain, and Spore Stain

Objectives

Become proficient in making and viewing Gram stain, acid-fast stain, and endospore stain slides.

Introduction

Most types of cells do not have much natural pigment and are therefore difficult to see under the light microscope unless they are stained. Several types of stains are used to make bacterial cells more visible. In addition, specific staining techniques can be used to determine the cells' biochemical or structural properties, such as cell wall type and presence or absence of endospores. This type of information can help scientists identify and classify microorganisms, and can be used by health care providers to diagnose the cause of a bacterial infection.

One type of staining procedure that can be used is the simple stain, in which only one stain is used, and all types of bacteria appear as the color of that stain when viewed under the microscope. Some stains commonly used for simple staining include crystal violet, safranin, and methylene blue. Simple stains can be used to determine a bacterial species' morphology and arrangement, but they do not give any additional information.

Scientists will often choose to perform a differential stain, as this allows them to gather additional information about the bacteria they are working with. Differential stains use more than one stain, and cells will have a different appearance based on their chemical or structural properties. Some examples of differential stains are the Gram stain, acid-fast stain, and endospore stain.

Gram Stain

This commonly-used staining procedure was first developed by the Danish bacteriologist Hans Christian Gram in 1882 (published in 1884) while working with tissue samples from the lungs of patients who had died from pneumonia. Since then, the Gram stain procedure has been widely used by microbiologists to obtain important information about the bacterial species they are working with. Knowing the Gram reaction of a clinical isolate can help the health care professional make a diagnosis and choose the appropriate antibiotic for treatment.

Gram stain results reflect differences in cell wall composition. Gram-positive cells have thick layers of peptidoglycan (a carbohydrate) in their cell walls; gram-negative bacteria have very little. Gram-positive bacteria also have teichoic acids, whereas gram-negatives do not. Gram-negative cells have an outer membrane that resembles the phospholipid bilayer of the cell membrane. The outer membrane contains lipopolysaccharides (LPS), which are released as endotoxins when gram-negative cells die. This can be of concern to a person with an infection caused by a gram-negative organism.

Gram stains are best performed on fresh cultures—older cells may have damaged cell walls and not give the proper Gram reaction. Also, some species

are known as gram-variable, and so both gram-positive and gram-negative reactions may be visible on your slide. Errors such as leaving on decolorizer too long can affect the results. In some cases, most cells will appear gram-positive while a few appear gram-negative. This suggests damage to the individual cells or that decolorizer was left on for too long; the cells should still be classified as gram-positive if they are all the same species rather than a mixed culture.

Although the vast majority of bacteria are either gram-positive or gram-negative, not all bacteria can be stained with this procedure (for example, a genus of bacteria called *Mycoplasma* has no cell walls and therefore stains poorly with the Gram stain).

Acid-fast stain

Most bacterial species are either gram-positive or gram-negative, however some organisms have different cell wall properties that make them difficult to stain with this method. For example, some species of bacteria have a waxy lipid (mycolic acid) in their cell walls. These organisms generally do not Gram stain very well (those that do would usually appear gram-positive) and these cells are instead more clearly visible with the acid-fast staining technique.

Acid-fast staining was developed by Robert Koch in 1882 and later modified by other scientists. Koch used the method to observe the “tubercle bacillus” — what we now call *Mycobacterium tuberculosis* — in sputum samples. While acid-fast and Gram staining are both differential stains, the acid-fast stain is much more specific. Many bacteria are either gram-positive or gram-negative, but very few are acid-fast. Two acid-fast genera that are important as human pathogens are *Mycobacterium* and *Nocardia*: Pathogenic species include *M. tuberculosis*, *M. leprae*, *M. bovis*, *M. avium*, and *N. asteroides*. The protozoan parasite *Cryptosporidium* can also be stained using this

procedure.

There are two major methods of acid-fast staining — both involve techniques that make the cell wall more permeable to the primary stain. The Ziehl-Neelson method uses steam heat to allow stain to penetrate, whereas the Kinyoun (cold method) uses a wetting agent mixed in with the primary stain. In this lab we will be using the Kinyoun method.

Endospore stain

Endospores are the most resistant forms of life. They can resist desiccation (drying), boiling, and radiation. In addition most disinfectants and antibiotics cannot penetrate an intact spore coat. For this reason endospores are difficult to eliminate from the environment with standard methods of disinfection, and organisms that produce endospores are difficult to treat in the case of an infection.

The production of endospores is a survival mechanism for particular bacterial species. When conditions are favorable, vegetative bacterial cells will continue to grow and divide; however when nutrients are depleted, these cells will begin to form endospores. Endospores are not metabolically active, but contain all the materials needed to regenerate a cell. When conditions for growth are again favorable, the spore will germinate and form a cell that is identical to the cell that produced it. Endospores are produced by certain types of gram-positive bacilli, like *Clostridium* and *Bacillus*, as well as other species. Endospore-forming pathogens include *C. tetani*, *C. botulinum*, *C. difficile*, and *B. anthracis*.

In this lab we will use the Schaeffer-Fulton method (without heat) to view endospores. Since we are not using heat, it is important to leave the stain on for a long time to allow it to penetrate the spore coat.

Materials

- Slides (at least three)
- Cultures of *E. coli*, *Staphylococcus aureus*, *Mycobacterium smegmatis*, and *Bacillus cereus*¹.
- Stains

¹ “MY-co-back-teer-ee-um smeg-MAH-tiss” and “buh-SILL-us SEER-ee-us”

Instructions

Make a Gram stain:

1. Make smears on a slide according to the diagram. (Clean slide, label with wax¹, spread organisms, air dry, and heat-fix.)
2. Dip slide in crystal violet for 30-60 seconds. (Primary stain)
3. Rinse off slide into stain waste beaker.²
4. Dip slide in Gram's iodine for 30-60 seconds. (Mordant³)
5. Rinse again.
6. Dip slide in 95% ethanol for 3-5 seconds.⁴ (Decolorizer⁵)
7. Rinse yet again.
8. Dip slide in 0.5% safranin for 60 seconds. (Counterstain⁶)
9. Rinse once more.
10. Blot slide dry in bibulous paper.
11. Observe slide under oil immersion on microscope. No cover slip is needed.
12. Repeat the above steps until you achieve the expected results.⁷

Make an acid-fast stain:

1. Make smears on a slide according to the diagram.
2. Dip slide in carbol fuchsin for 20 minutes. (Primary stain⁸)
3. Rinse slide over stain-waste beaker.
4. Dip slide in acid-alcohol for 3-5 seconds. (Decolorizer)
5. Rinse again.
6. Dip slide in methylene blue for 30 seconds. (Counterstain)
7. Rinse once more.
8. Blot slide dry in bibulous paper.
9. Observe slide under oil immersion on microscope. No cover slip is needed.
10. Repeat the above steps until you achieve the expected results.⁹

Make an endospore stain:

1. Make smears on a slide according to the diagram.
2. Dip slide in malachite green for 30 minutes. (Primary stain¹⁰)
3. Rinse slide over stain-waste beaker. (Decolorizer)
4. Dip slide in 0.5% safranin for one minute. (Counterstain)
5. Rinse once more.
6. Blot slide dry in bibulous paper.
7. Observe slide under oil immersion on microscope. No cover slip is needed.
8. Repeat the above steps until you achieve the expected results.¹¹

¹ Other labeling methods are likely to wash off, especially in ethanol and acid-alcohol.

² Rinse until water runs off clear. There is no need to dry the slide between staining steps.

³ A mordant is a substance used to set or stabilize stains or dyes; in this case, Gram's iodine acts like a trapping agent that complexes with the crystal violet, making the crystal violet-iodine complex clump and stay contained in thick layers of peptidoglycan in the cell walls.

⁴ This is a critical step. Smears that are too thick will not release their primary stain during this step. Sometimes 8-10 seconds of decolorization can help with overly thick smears.

⁵ Cells that have thick peptidoglycan layers in their cell walls are much less affected by the decolorizing agent; they generally retain the crystal violet dye and remain purple. However, the decolorizing agent more easily washes the dye out of cells with thinner peptidoglycan layers, making them again colorless.

⁶ This stains the decolorized cells pink, and is less noticeable in the cells that still contain the crystal violet dye.

⁷ Gram-positive organisms should be violet, and Gram-negative organisms should be red or pale red.

⁸ Time acts as the mordant in this type of acid-fast stain. Other acid-fast stain protocols use heat to make the primary stain penetrate cells.

⁹ Acid-fast organisms should be hot-pink. Non-acid-fast organisms should be blue.

¹⁰ Like the acid-fast stain, time acts as the mordant in this type of endospore stain. Other endospore stain protocols use heat to make the primary stain penetrate cells.

¹¹ Endospores should be green, and all cells should be red or pale red. Some organisms with waxy cell walls may appear green, but these are not endospores. Compare sizes to tell the difference: Endospores are smaller than the cells that made them, and careful searching may reveal a red cell with a spore inside. If the green structures are identical in size to the red structures, or if there are no red structures, the green items are probably not endospores.

Gram stain appearances

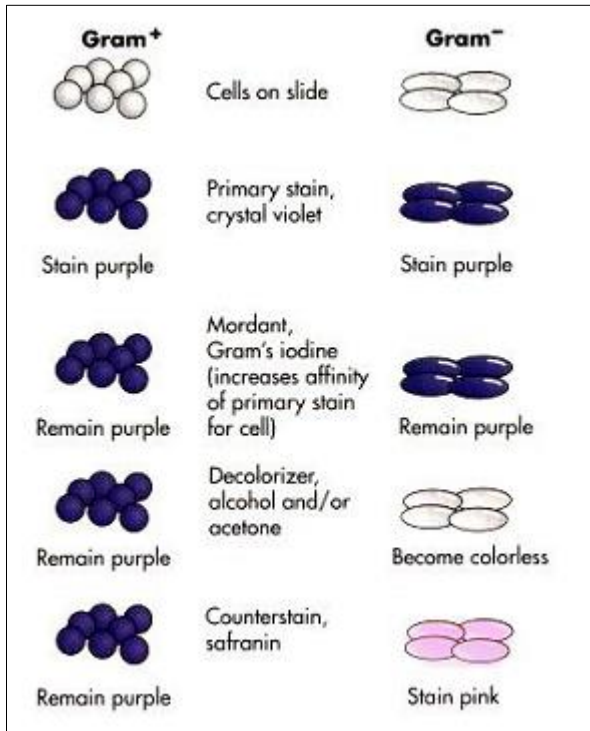

Gram stain diagram from Biology – LibreTexts. 2016. Accessed 2018.

Endospore positions

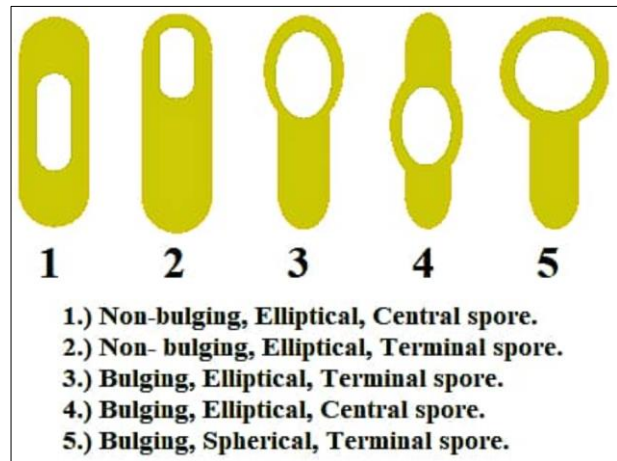

Spore position diagram from S. Batra. 2017. Endospore Staining. Paramedics World. Accessed 2018.

Life cycle of a spore-forming bacterium.

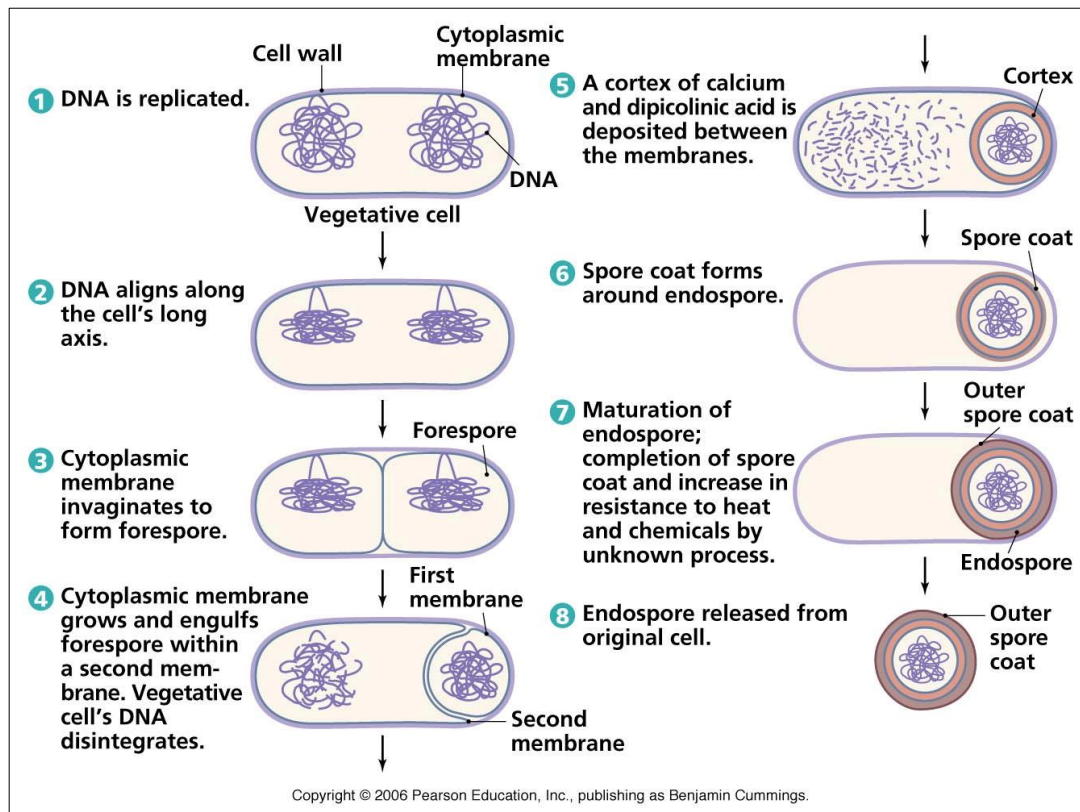

Observations

Draw diagrams of the slides you made, along with notes of your observations.

Disposal / Clean-up

1. Any stain waste that contains acid-alcohol must be discarded in the hazardous waste container in the fume hood.
2. You may wish to save your slides in the slide box to review later. If so, use lens paper or a Kimwipe to gently dab off any immersion oil. (If you wipe the slide, you will wipe off your organisms.)
3. When you have finished your observations of these slides, you may clean, dry, and return the slides.

Slide-cleaning tips:

- Put a drop of acid-alcohol on the slide, and wipe with a paper towel. Most of the stain should come off.
- Remove wax with a dry paper towel.
- Soap and water also works, but be careful to dry the slides afterwards.

Review questions

1. What is a differential stain?
2. What is the mordant in the Gram stain? Why is it needed?
3. What is the decolorizer in the Gram stain? Why is it needed?
4. What is the counterstain for the Gram stain? Why is it needed?
5. What major structural differences distinguish the gram-positive and gram-negative cell walls?

6. Why does the age of the bacterial culture matter for Gram staining?

7. List the chemicals used in the major steps of the Gram stain. (You can leave out any rinsing steps.) Fill in the color of the cells after each step.

Step	Chemical	Appearance	
		Gram-positive cells	Gram-negative cells
1			
2			
3			
4			

8. Could you use a Gram stain instead of an acid-fast stain to get the same information? Why or why not?

9. What are the Gram reactions of *Mycobacterium* and *Bacillus*?

10. When is it appropriate to use an acid-fast stain?

11. How might *Mycobacterium*'s acid-fast cell wall affect its ability to cause disease?

12. Name two genera of bacteria that are acid-fast. Name a disease associated with each.

13. Are bacterial endospores a form of reproduction? Why do you say so?

14. Why is it useful for *Clostridium* to be able to make an endospore?

15. Why is awareness of endospores important for people in clinics and in food production?

16. This flowchart helps distinguish among organisms by asking questions that have one of two possible answers. As a result, this flowchart can also be called a dichotomous key (from Greek *dikho-* 'in two' + *temnein* 'to cut'). Complete the flowchart by properly placing these genera: *Bacillus*, *Corynebacterium*, *Escherichia*, *Mycobacterium*, *Neisseria*, and *Staphylococcus*. You may need to look up additional information about these genera.

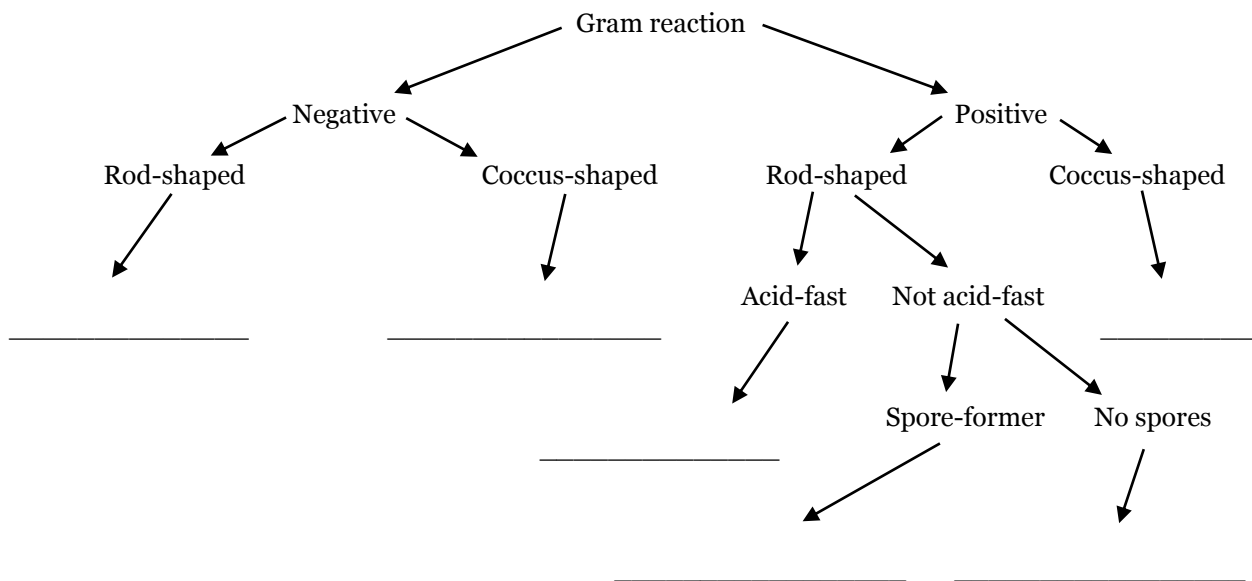

17. Construct your own flowchart for these genera. The information in the table will be useful.

Genera	Morphology	Gram reaction	Motile?	Capsule?	Arrangement	Endospore?
<i>Clostridium</i>	Bacilli	+	+	–	Pairs, chains	+
<i>Enterobacter</i>	Bacilli	–	+	–	Singles, pairs	–
<i>Klebsiella</i>	Bacilli	–	–	–	Singles, pairs	–
<i>Lactobacillus</i>	Bacilli	+	Rarely	–	Chains	–
<i>Staphylococcus</i>	Cocci	+	–	–	Pairs, clusters	–
<i>Streptococcus</i>	Cocci	+	–	Some species	Pairs, chains	–

18. Imagine that you have used the Gram staining procedure to stain an L-form bacterium (a bacterium that lacks a cell wall). What color will the bacterium be after the staining procedure is finished?

19. Match the unexpected results with all of their potential explanations. Explanations can be used multiple times.

Unexpected results

- _____ Organism appears red, but is actually Gram-positive.
- _____ Organism appears violet, but is actually Gram-negative.
- _____ Organism has no color.
- _____ Cells appear to be fused together.
- _____ No cells are visible on the slide.
- _____ Organism appears hot-pink, but is not acid-fast.
- _____ Organism appears blue, but is acid-fast.

Potential explanations

- A. Slide was decolorized too long.
- B. Slide was not decolorized long enough.
- C. Smear was too thick, and held on to the primary stain.
- D. Cells were overheated on slide, either during the drying or heat-fixing process.
- E. Smear was not heat-fixed.
- F. Culture was more than 24 hours old.

Identification of Unknown Bacteria

Microbiologist: _____ Date: _____

Culture number: _____

Objective

Practice differential staining and identify an unknown bacteria species by interpreting your staining results.

Instructions

1. Record your culture number above.
2. Perform the Gram stain, acid-fast stain, and endospore stain on your unknown organism.
3. Record your results below.
4. Have your instructor initial your Gram stain results, to check that your interpretation is reasonable.
5. Dispose of any stain waste in the hazardous-waste container.

Gram stain

Acid-fast stain

Endospore stain

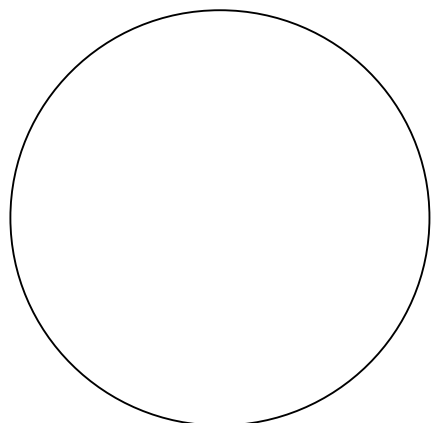
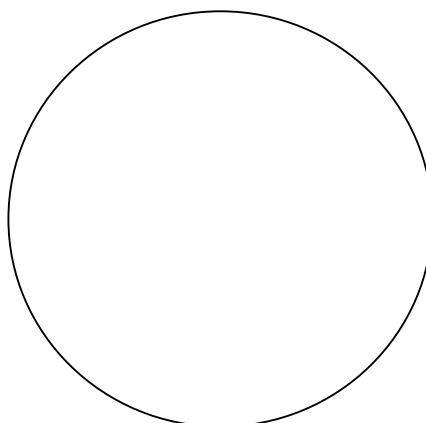
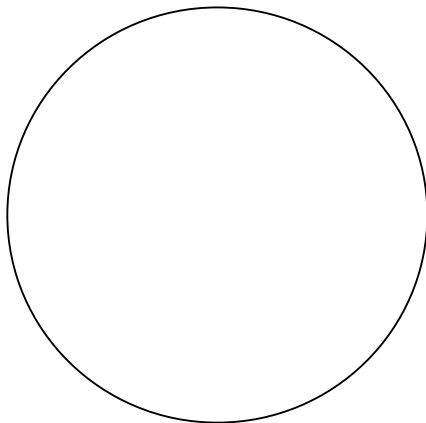

Instructor initials: _____
(for Gram stain)

- What is the cell shape?
- What is the cell arrangement?
- What is the cell's Gram reaction?

- Is the unknown acid-fast?

- Does the unknown produce endospores?

- What is the species name of your unknown?

Part 4: Eukaryotic Microorganisms

Exercise 6: Fungi

Objectives

- Learn to distinguish among types of hyphae.
- Learn yeast morphology (budding, pseudohyphae).
- Learn to distinguish among several different fungi based on their physical characteristics.
- Learn vocabulary associated with fungi parts.
- Learn the importance of HardyCHROM differential culture media.
- See the parts of lichen.

Introduction

So far our laboratory exercises have been primarily focused on prokaryotic organisms—those that lack a nucleus and other membrane-bound organelles. However, there are other types of eukaryotic microorganisms that exist in nature, some of which cause human disease. In this exercise we will examine representative types of eukaryotic microorganisms: fungi, protozoa, and parasitic worms (helminthes), and learn about the diseases that they cause.

The Fungi

Fungi are heterotrophs (organisms that require organic carbon). In nature they are important saprotrophs—organisms that decompose dead organic matter. Many fungi produce enzymes that decompose woody plant material—thus making them of critical importance for nutrient recycling in forests. Some types of fungi live in a symbiotic relationship with a photosynthetic algae or bacterium (lichens)—others live in symbiosis with plant roots (mycorrhizae). Fungi are also an important food source for humans and other organisms, and are used in food production as well. Fungi have a cell wall composed primarily of chitin (a polymer of glucose).

Members of the Kingdom Fungi exist as multinucleate filaments (molds) or unicellular yeasts. Molds have long branching cellular structures called hyphae that grow continuously without complete division of cytoplasm. Several hyphae may form a visible mat called mycelium. Most hyphae grow along the substrate (vegetative hyphae) but those that produce spores extend

upwards to disperse them (aerial or reproductive hyphae). Hyphae may or may not have septa that partially separate the cytoplasm.

Yeasts are unicellular fungi with an oval or spherical shape that replicate either by uneven or even cell division (uneven cell division is called budding). Some fungi exhibit thermal dimorphism: they grow as filamentous molds at room temperature, but grow as yeasts at 37°C.

Among the human pathogens, many can cause opportunistic infections by taking advantage of a weakened or immunocompromised host. Other species of fungi produce toxins that can affect humans when consumed: some affect humans indirectly causing disease in crop plants and animals that humans rely on for food.

Fungi are often grouped based on the types of spores produced during sexual reproduction.

Zygomycota form zygospores in sexual reproduction and form sporangiospores (encased in a sac known as a sporangium) in asexual reproduction. Zygomycota usually have aseptate / coenocytic hyphae. An example of Zygomycota:

- *Rhizopus stolonifer* (black bread mold)

Ascomycota form ascospores (encased in a sac known as an ascus) in sexual reproduction, and form unprotected conidiospores in asexual reproduction. Ascomycota usually have septate hyphae. Examples of Ascomycota:

- *Penicillium notatum*: produces penicillin

- *Aspergillus*—includes *A. fumigatus* (causes aspergillosis) and *A. flavus* (produces carcinogenic aflatoxins)
- *Saccharomyces* (Baker's yeast): used in baking and alcohol production
- *Candida albicans*: causes yeast infections and thrush
- *Pneumocystis jiroveci*: leading cause of pneumonia among AIDS patients

Basidiomycetes form basidiospores in sexual reproduction but do not have a well-defined asexual mode of reproduction. The mushroom is a

macroscopic fruiting body of this type of fungus—basidiospores are formed on the underside of the mushroom cap (basidiocarp). Although mushrooms are clearly visible without a microscope, most of the living biomass of these fungi exists as microscopic hyphae. Examples of Basidiomycota:

- *Agaricus* (edible)
- *Amanita* (poisonous)
- *Cryptococcus neoformans*: found in pigeon droppings; can cause severe infections in immunocompromised patients

Define the following terms, regarding fungi:

- mycology:
- mycosis:
- mold:
- hyphae:
 - septate hyphae:
 - aseptate / coenocytic hyphae:
 - vegetative hyphae:
 - reproductive / aerial hyphae:
 - pseudohyphae:
- mycelium:
- yeast:
- budding:
- dimorphic fungi:
- fungal spores:
 - asexual fungal spores:
 - conidiospores / conidia:
 - sporangiospores:
 - sporangium:
 - sexual spores / zygospores:

Materials

- *Saccharomyces cerevisiae* (baking yeast), both living and on a slide
- *Candida albicans* slide
- *Rhizopus* sp., living and on a slide
- *Penicillium* sp., living and on a slide
- *Aspergillus* sp., living and on a slide
- *Trichophyton* sp. (ringworm fungus) slide
- *Coccidioides immitis* slide
- *Pneumocystis jiroveci*
- Lichen

Instructions

1. Prepare a wet mount of *Saccharomyces cerevisiae* (baking yeast, “sac-uh-row-MY-sees sair-uh-VIZ-ee-ee”) . Include a drop of blue stain to increase contrast. When you are done observing this slide, it can be cleaned with soap and water.

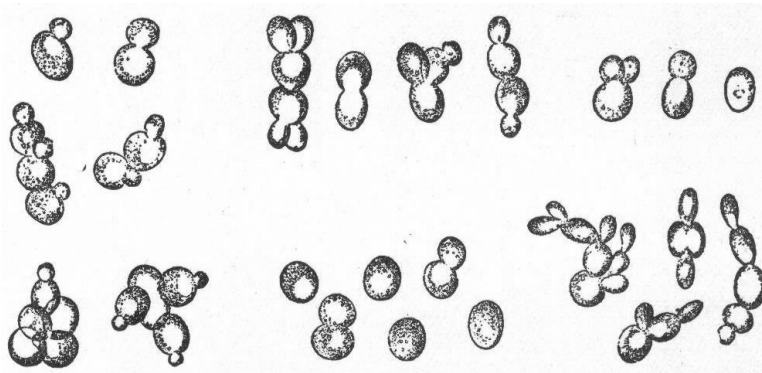
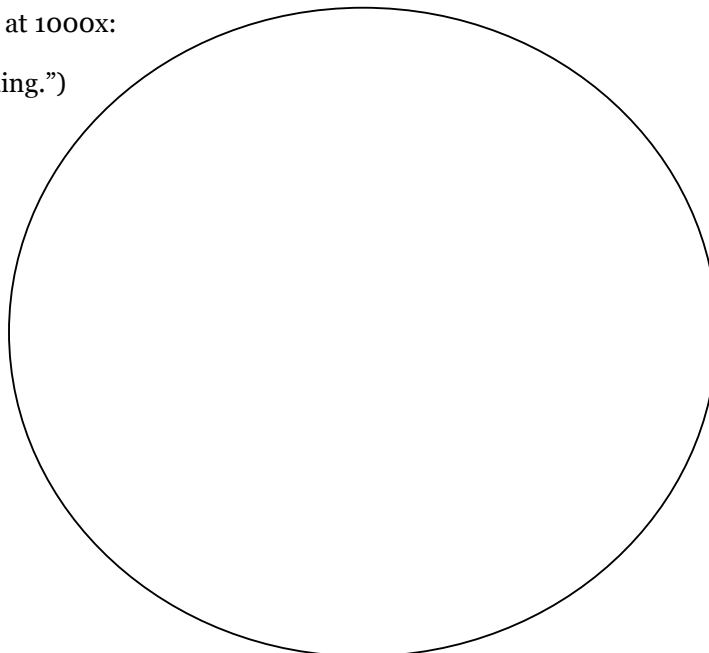

Figure of budding yeast from The New Student's Reference Work, 1914 edition, volume 5, page 137.
Retrieved from commons.wikimedia.org.

Wet mount observations, at 1000x:

(Observe and label “budding.”)



2. Observe the prepared slide of *Candida albicans* (can-DEE-duh AL-bih-cans) at 1000x:

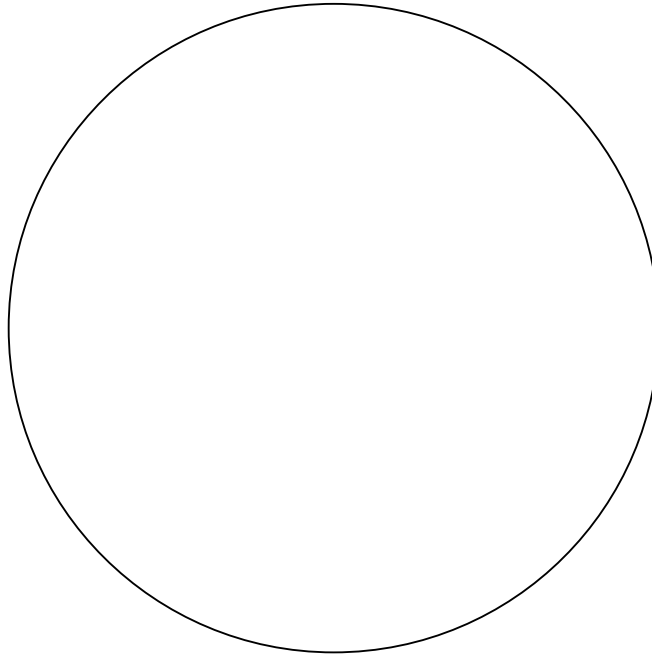

3. It can be difficult to determine which specific yeast species is causing an infection. Differential media can make species grow in different colors, due to the way specific enzymes in the yeast react with the medium. Record the colors associated with these species on the HardyCHROM™ Candida plate.

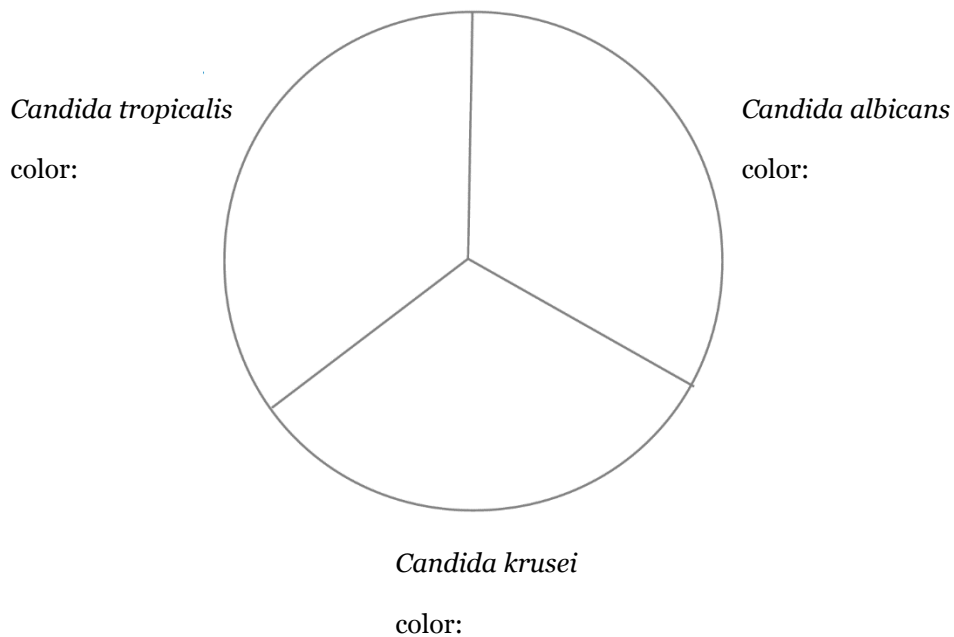

4. Use the dissecting microscope to examine the living mycelium of *Rhizopus* sp. (RYE-zow-pus). Do not open the culture. Sketch the overall mold colony, and the aerial hyphae. Note the color.

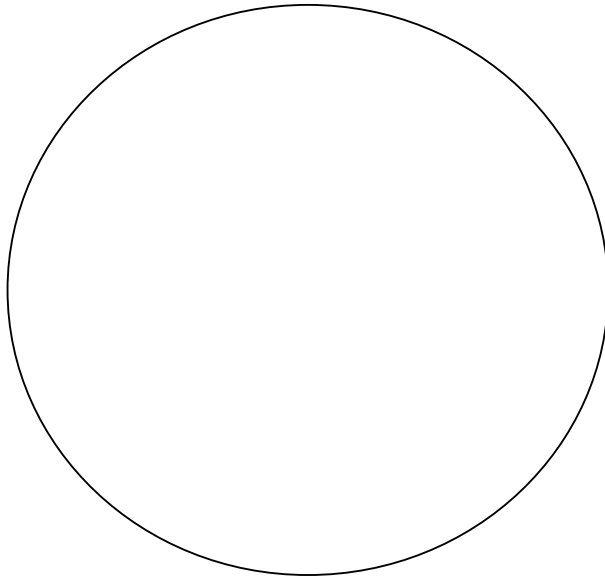

5. Observe the prepared slide of *Rhizopus* sp. at 100x (low power). Sketch and label the aseptate hyphae, sporangium, sporangiospores, and zygospores. (These may be found on separate slides.)

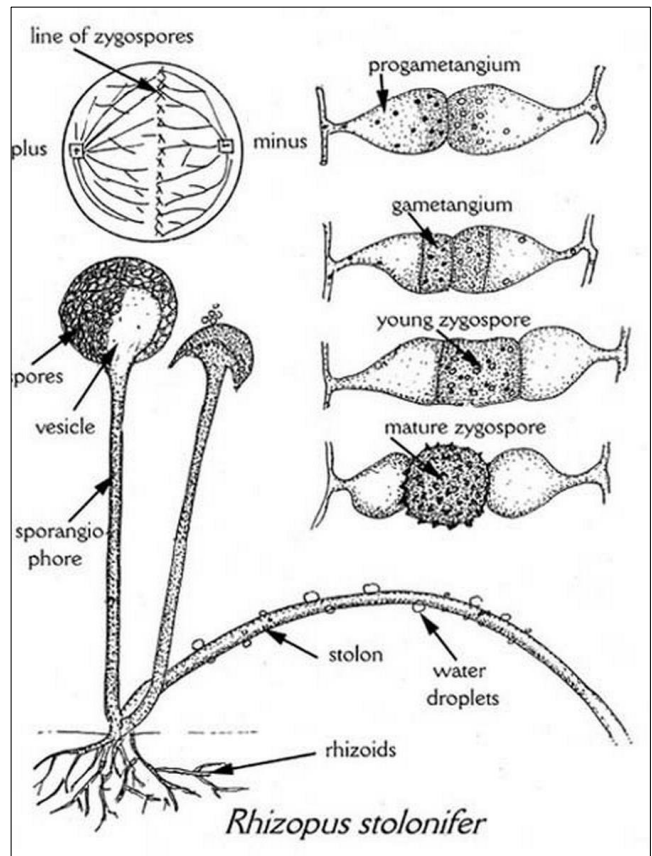
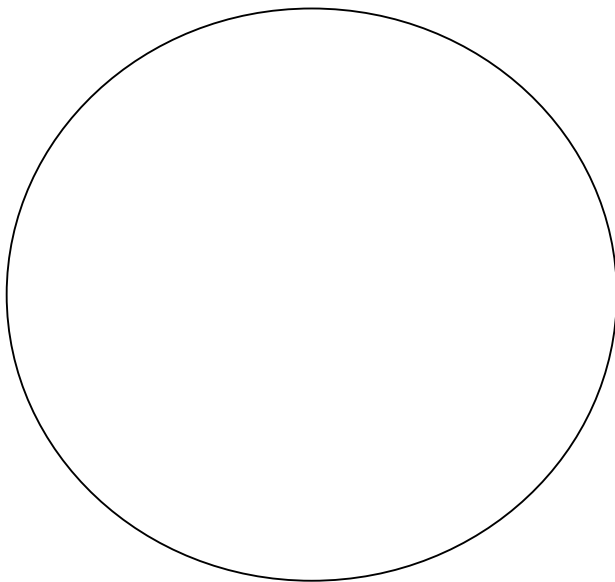

Figure of *Rhizopus* life stages from G. Barron. 2013. The Atrium. University of Guelph. Accessed 2018.

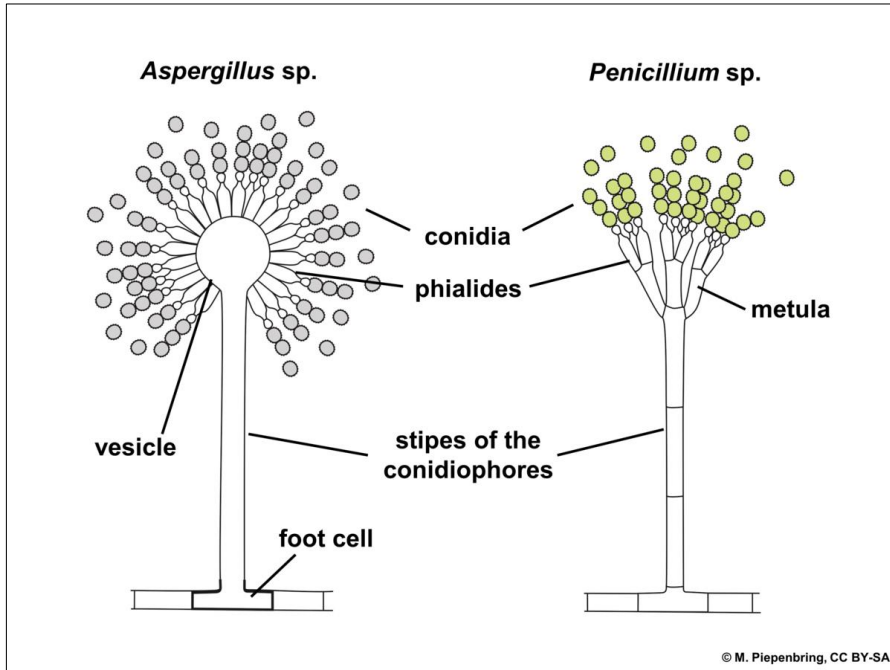
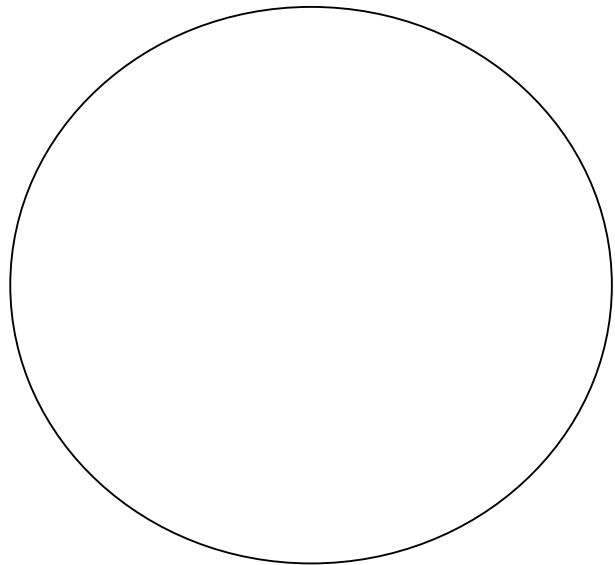
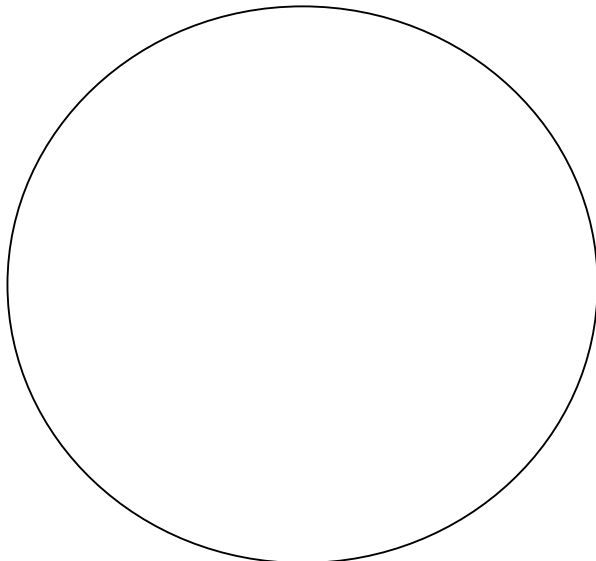

Figure showing structures of *Aspergillus* and *Penicillium* aerial hyphae.

6. Use the dissecting microscope to examine the living mycelium of *Penicillium* sp. (pen-uh-SILL-ee-um). Do not open the culture. Sketch the overall mold colony, and the aerial hyphae. Note the color.

7. Observe the prepared slide of *Penicillium* sp. at 1000x. Sketch and label the septate hyphae, conidiophore, and conidiospores / conidia.



8. Use the dissecting microscope to examine the living mycelium of *Aspergillus* sp. (ass-purr-GILL-us). Do not open the culture. Sketch the overall mold colony, and the aerial hyphae. Note the color.

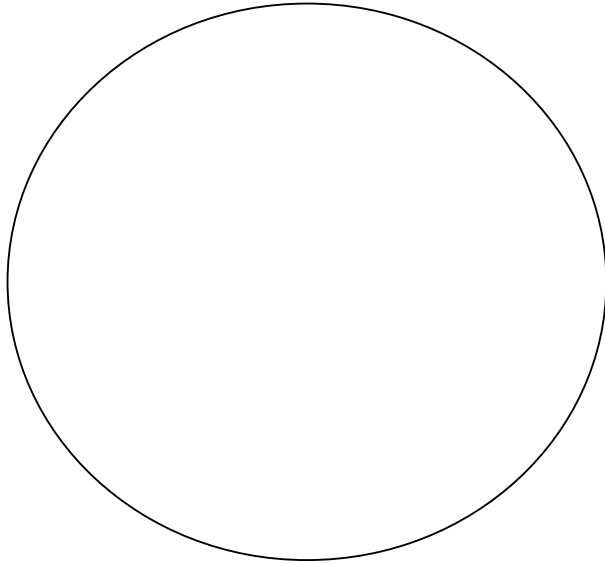

9. Observe the prepared slide of *Aspergillus* sp. at 1000x. Sketch and label the septate hyphae, conidiophore, and conidiospores / conidia.

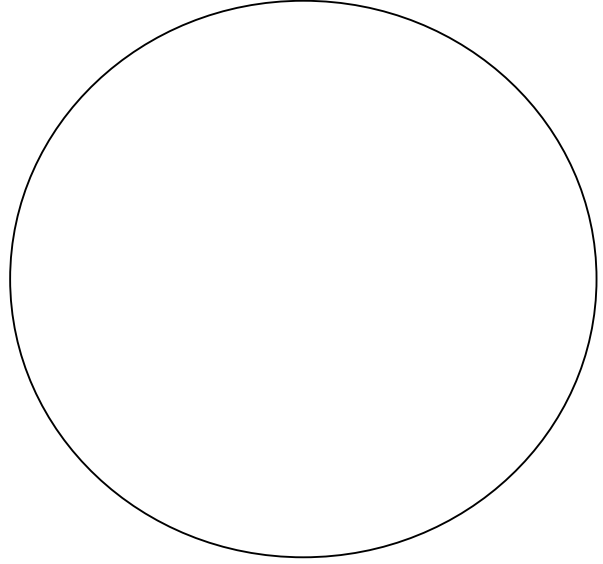

10. Observe the prepared slide of *Trichophyton* sp. (ringworm fungus, “trick-oh-FY-tun”). Some other fungi that cause ringworm are *Epidermophyton* spp. and *Microsporum* spp. This slide shows a section of infected skin. Find the multicellular spores at 1000x.

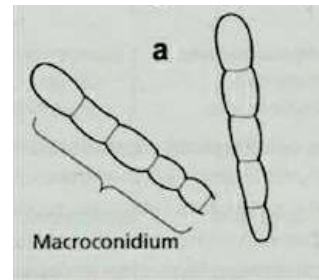
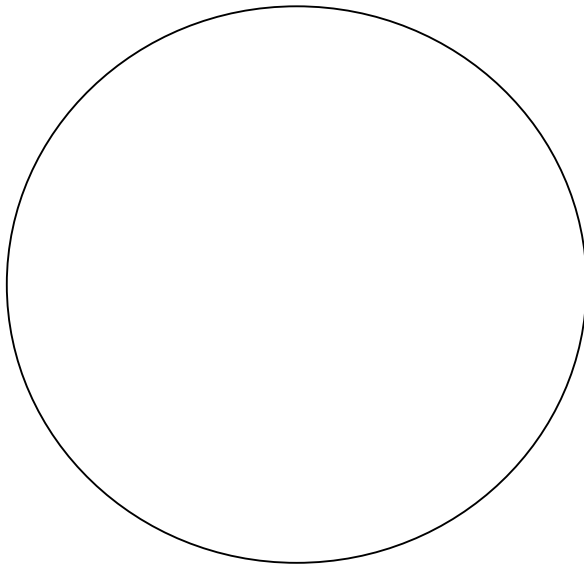

Trichophyton in part a of this figure. From Jim Deacon, University of Edinburgh.

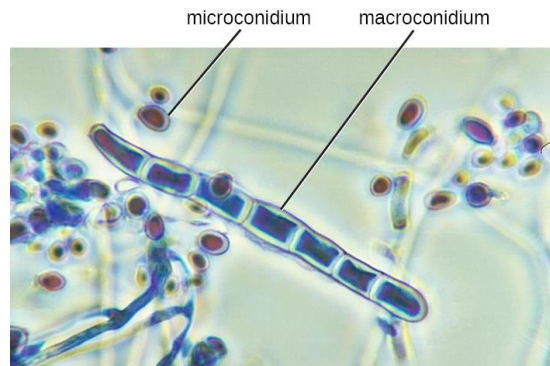

Microscope image of *Trichophyton* from OpenStax Microbiology.

11. Observe the prepared slide of *Coccidioides immitis* (COCK-sid-ee-OY-dees imm-EYE-tiss) at 1000x. Find the arthroconidia.

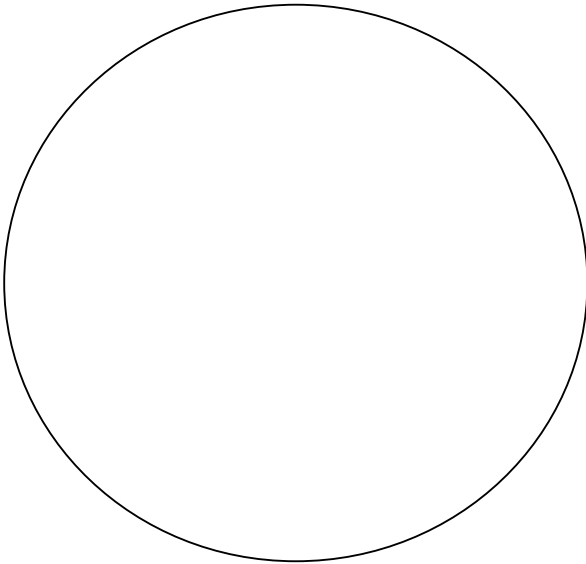

Arthroconidia image from CDC/Dr. Hardin, 1965. Wikimedia Commons.

Name of disease caused by this organism:

Part(s) of the body affected:

How the pathogen is transmitted:

12. Observe the prepared slide of *Pneumocystis jirovecii* (NEW-mow-siss-tuss JYE-row-veh-chi) at 1000x. This slide shows part of a crushed rat lung. Find the tiny round cysts with eight intracystic bodies.

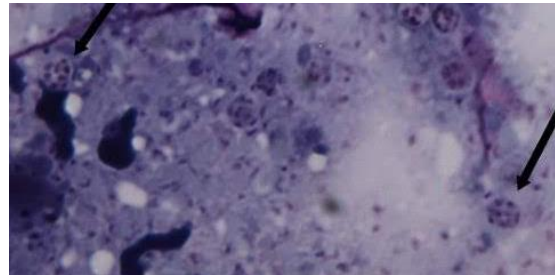
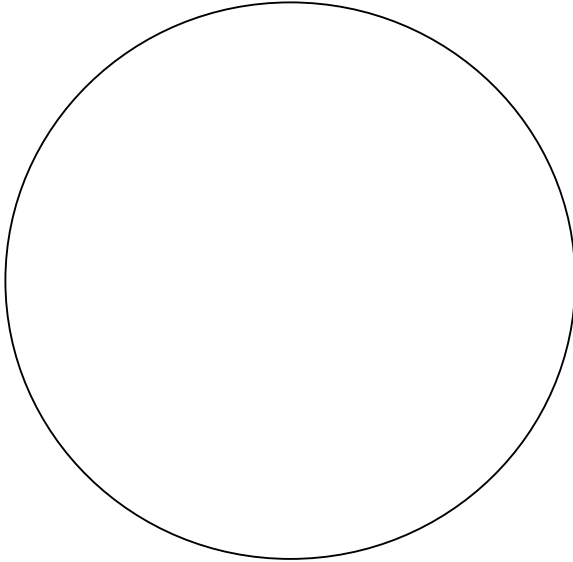

Pneumocystis (at arrows) image from Cindy Anderson, Mt. SAC.

Name of disease caused by this organism:

Part(s) of the body affected:

How the pathogen is transmitted:

13. Make a wet mount of the crushed **lichen** (LIKE-enn). Find the fungal hyphae and algae cells at 400x (high power). Label your drawing.

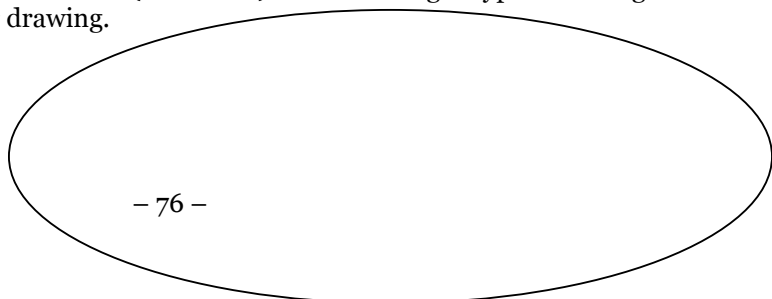

Clean-up

Clean all slides with Kimwipes or lens paper. Remove all oil from your microscope.

Review questions

1. Both *Penicillium* sp. and *Aspergillus* sp. reproduce asexually with conidia. How can you tell these organisms apart with a microscope? How about without a microscope?

2. What disease can be caused by *Aspergillus* sp.?

What part of the body is affected?

How is the disease transmitted?

3. What are the roles of the algae and the fungus in a lichen?

4. Clinical application: A 44-year-old man with HIV is receiving antibiotics through an intravenous catheter. The antibiotics are to help treat a kidney infection. The patient develops a fever. Subsequent cultures from the patient's blood, the needle tip, and from the insertion site all show growth of an organism with large oval-shaped cells. The cells reproduce by budding.

(a) What is your guess about the identity of the pathogen?

(b) How do you think the antibiotics may have contributed to this outcome?

(c) What do you think the portal of entry was for this pathogen?

5. Clinical application: An 83-year-old woman is hospitalized with pneumonia. She is given penicillin and is discharged seven days later, when her symptoms subside. The same patient is readmitted again with pneumonia, two weeks later. A lung biopsy shows no bacteria or viruses. The patient is given broad-spectrum antibiotics, and she returns home after 8 days in the hospital. When the patient develops pneumonia again, a bronchoscopy shows septate hyphae in her lung tissue. The patient keeps no pets, she is not a gardener, and she is not fond of the outdoors. Investigators find some sparrows nesting outside her bedroom window, and some *Aspergillus* is cultured from her humidifier.

(a) What is your guess about the identity of the pathogen?

(b) Why did it take so long to diagnose this pathogen?

(c) Why did the woman's infection keep returning?

Name _____

Date _____

Section # _____

Exercise 7: Protists

Objectives

Compile information about several protozoa, and learn to distinguish among them based on unique physical characteristics.

Introduction

Protists are an informal grouping of eukaryotes that are not plants, animals, or fungi. Algae and protozoa are examples of protists.

Protozoa (singular: protozoan) are protists that make up the backbone of many food webs by providing nutrients for other organisms. Protozoa are very diverse. Some protozoa move with help from hair-like structures called cilia or whip-like structures called flagella. Others extend part of their cell membrane and cytoplasm to propel themselves forward. These cytoplasmic extensions are called pseudopods (“false feet”). Some protozoa are photosynthetic; others feed on organic material. Some are free-living, whereas others are parasitic, only able to survive by extracting nutrients from a host organism. Most protozoa are harmless, but some are pathogens that can cause disease in animals or humans.

They are found in all types of habitats, including soil, freshwater and saltwater. Protozoans do not have cell walls, but many are surrounded by a proteinaceous outer covering called a pellicle. Both sexual and asexual modes of reproduction occur in this group.

Protozoan pathogens vary in their mode of transmission, or method of gaining access to a new host. Some are transmitted by vector (an insect or arthropod that transmits a microbial pathogen), by

ingestion of contaminated food or water, or even by sexual contact. Many species form a dormant stage called a **cyst** that is resistant to adverse environmental conditions. This allows cysts to exist outside of a host cell for some time, and the cyst is often the stage that is transmitted to a new host. The feeding (or metabolically-active) form of these organisms is known as a **trophozoite** (TRO-fo-ZO-ite).

Protozoa are often informally grouped based on the type of structures they use for locomotion (motility).

- Amoebozoans use cytoplasmic projections called pseudopodia.
 - ex: *Entamoeba histolytica*
- Flagellates use flagella.
 - *Trypanosoma gambiense*
 - *Trypanosoma cruzi*
 - *Giardia lamblia (intestinalis)*
 - *Trichomonas vaginalis*
- Ciliates use cilia.
 - *Balantidium coli*
 - *Paramecium* spp. (non-pathogenic)
- Apicomplexans have no means of locomotion in their mature form.
 - *Plasmodium vivax*
 - *Toxoplasma gondii*

Materials

- *Amoeba proteus* (living)
- *Paramecium* sp. (living)
- *Entamoeba histolytica* slide
- *Balantidium coli* slide
- *Trypanosoma cruzi* slide
- *Trypanosoma brucei gambiense* slide
- *Trichomonas vaginalis* slide
- *Giardia lamblia* slide (also known as *G. intestinalis* and *G. duodenalis*)
- *Leishmania donovani* slide
- *Plasmodium vivax* slide
- *Toxoplasma gondii* slide
- *Cryptosporidium parvum* slide

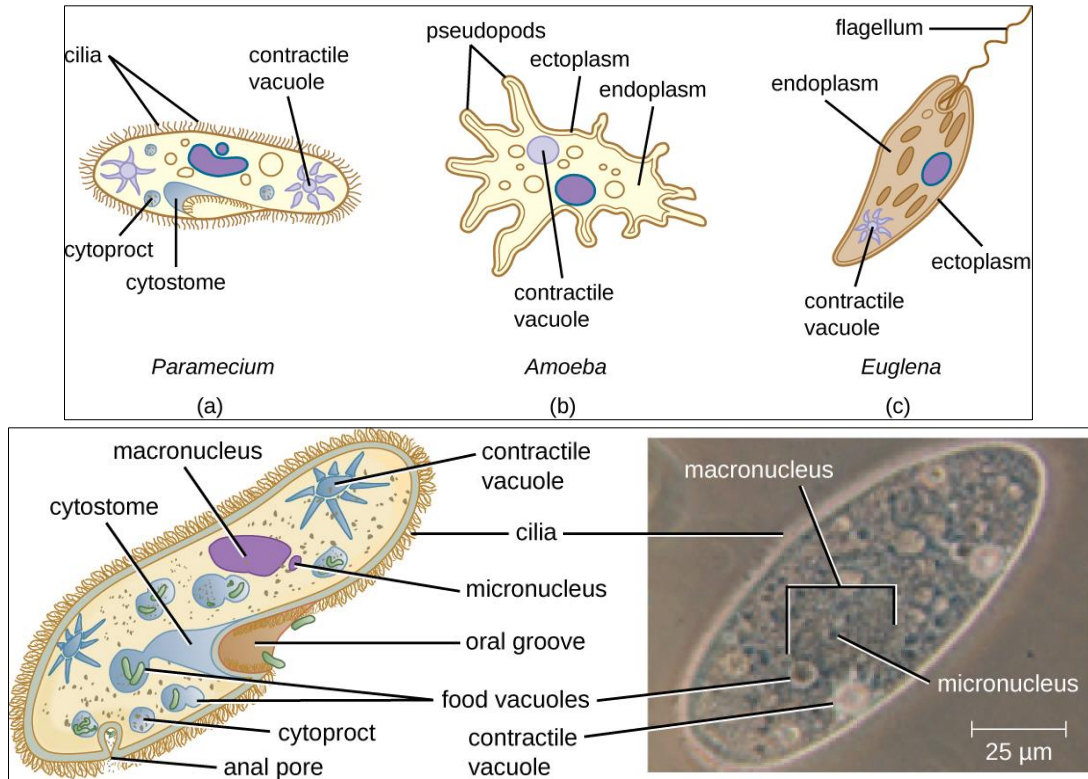

Amoeba and *Paramecium* figures from OpenStax Microbiology, 2016.

Instructions

1. Make a wet mount slide of *Amoeba proteus* (uh-MEE-buh PRO-tee-us). Use a flat slide but no cover slip. The amoebas are fragile. Use a dropper to retrieve one or two from the bottom of the culture container. It may take several tries to capture one from the culture container. Observe at 100x (low power). The small, fast-moving organisms are usually other protozoans called *Chilomonas*, which feed on the rice grain. The *Chilomonas* then serve as food for the large, slow-moving amoebas.

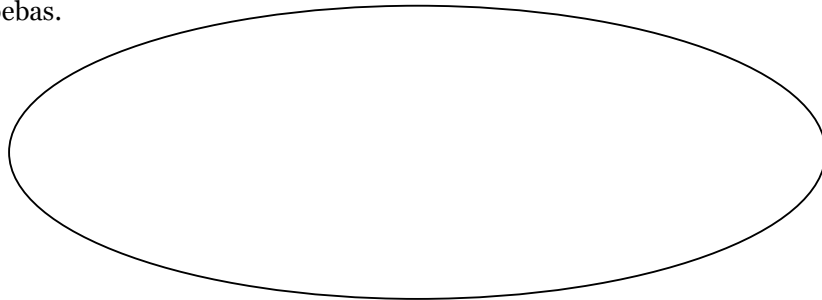

2. Make a wet mount slide of *Paramecium* sp. (pare-uh-MEE-see-um) and add a drop of methyl cellulose to slow them down. It may take several tries to capture one from the culture container. Observe at 100x.

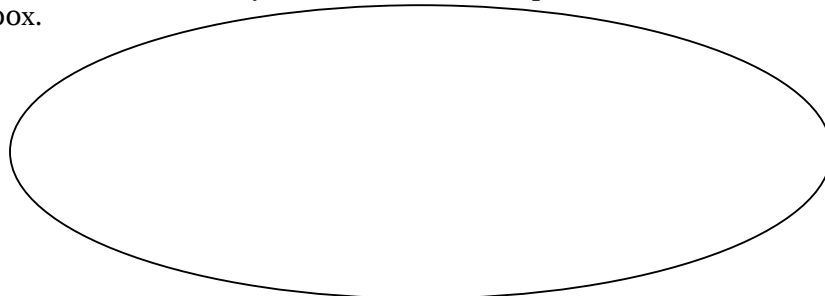

3. Observe these remaining slides to find the suggested life stages and features.

Entamoeba histolytica (en-tuh-MEE-buh hiss-toe-LIH-tih-kuh). This is a fecal smear; draw at 400x; notice the bull's-eye nuclei.

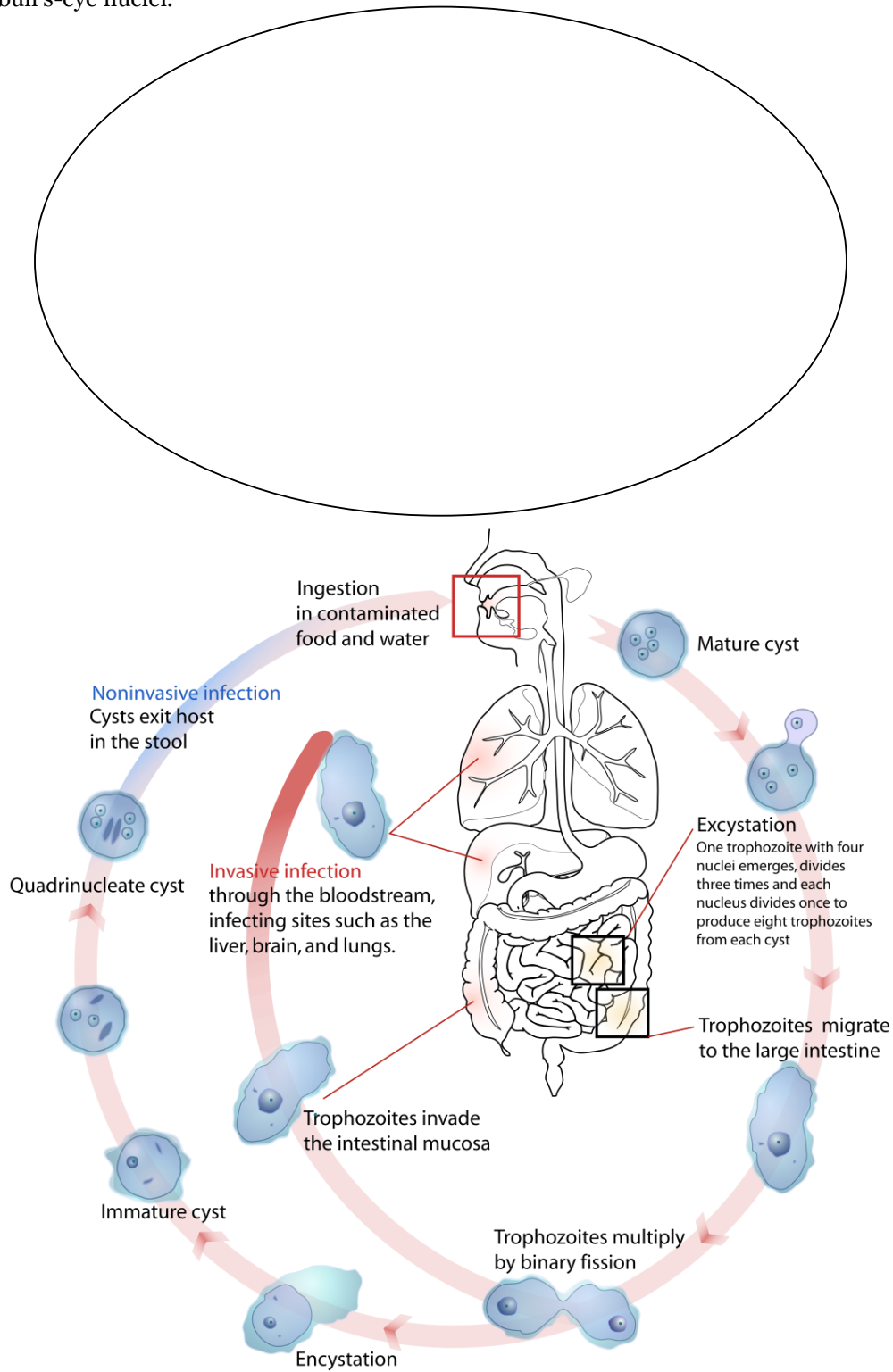
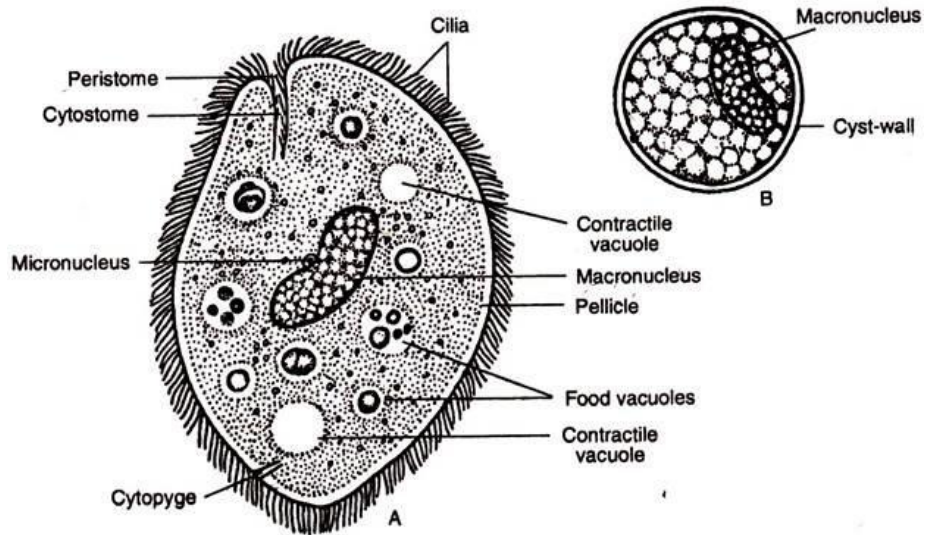
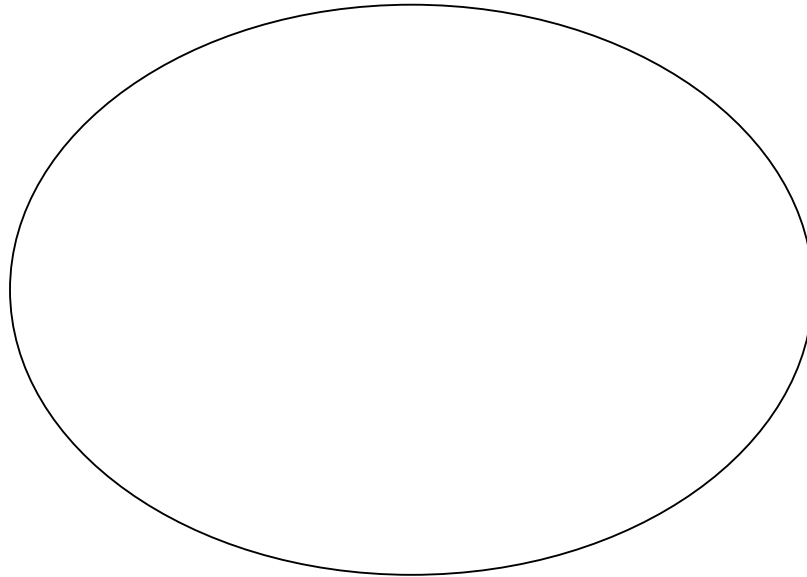

Figure of *Entamoeba histolytica* from LadyofHats, Public domain, Wikipedia. 2008.

Balantidium coli (bal-ann-TIDD-ee-umm COAL-eye). This is a fecal smear; draw at 400x or 1000x; try to find a trophozoite and a cyst; notice the shape of the macronucleus.



Balantidium coli figure from "Example of Phylum Protozoa: Balantidium coli."
Khusboo Jain. www.biologydiscussion.com. Accessed 2018.

Trypanosoma cruzi (trih-PAN-oh-soam-uh CRUISE-eye). Draw at 1000x; notice the flagella attached to an undulating membrane.

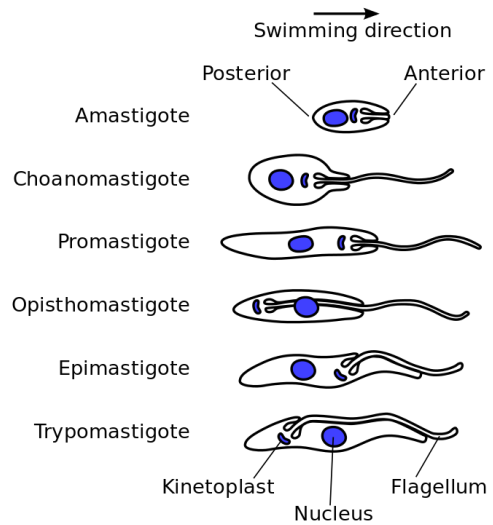
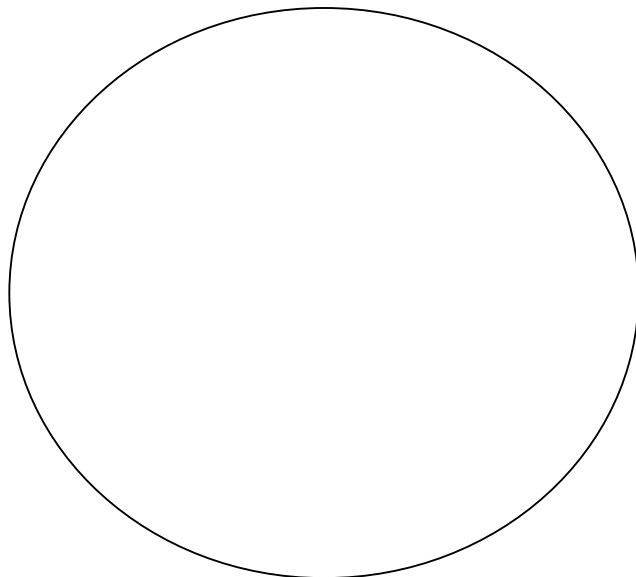

Figure of trypanosomatid morphologies. Notice the swimming direction, and that the position of the flagellum changes. The names of these stages are beyond the scope of this course. (From Zephyris, Public domain, Wikipedia. 2011.)

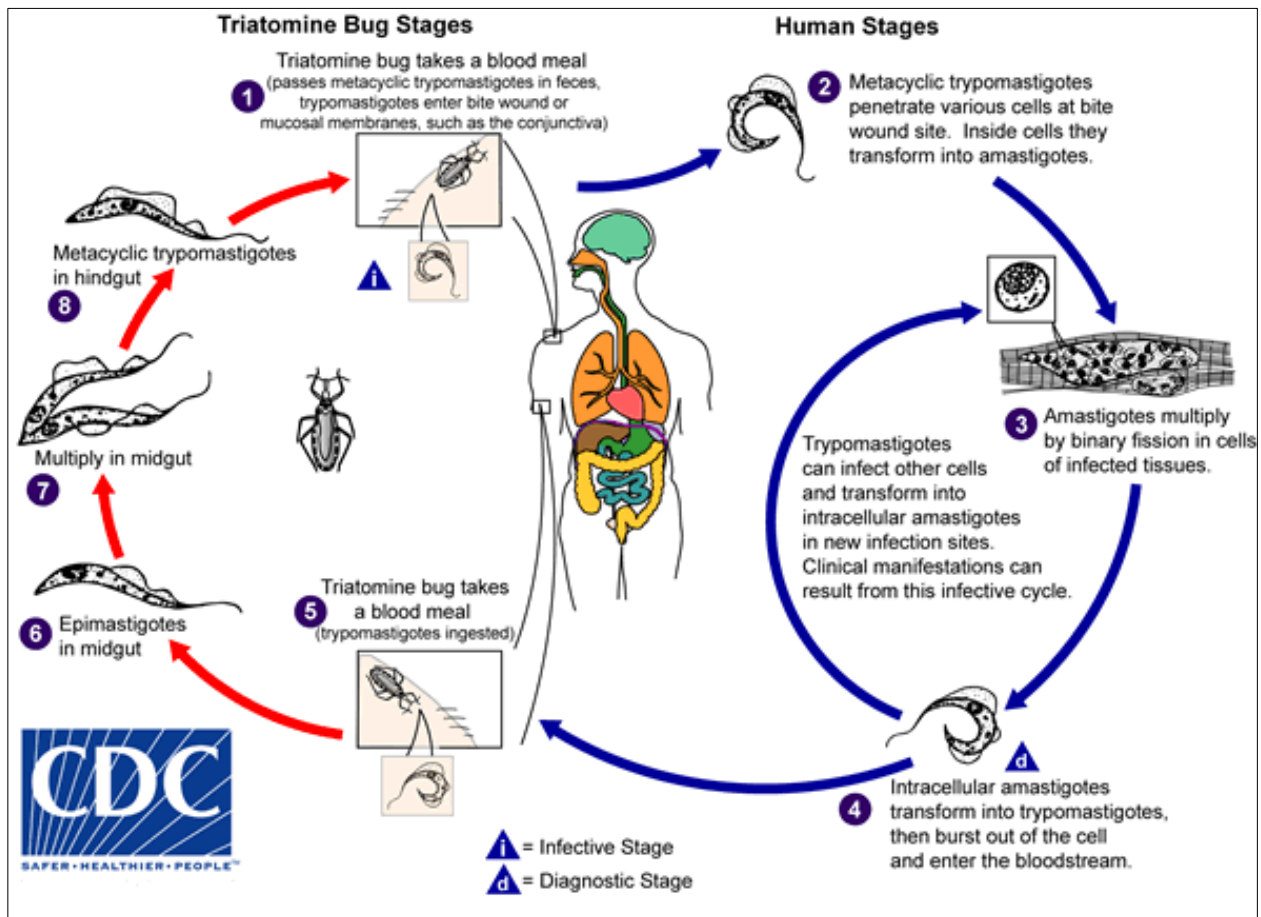
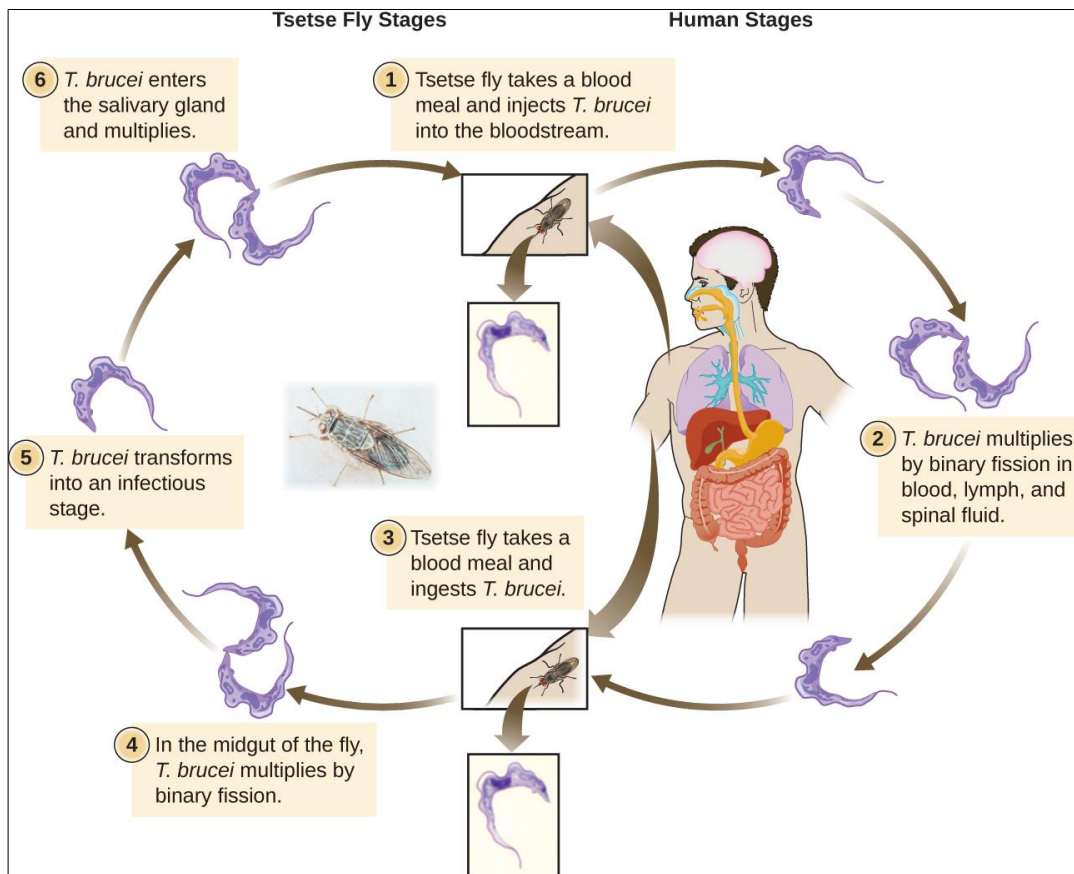
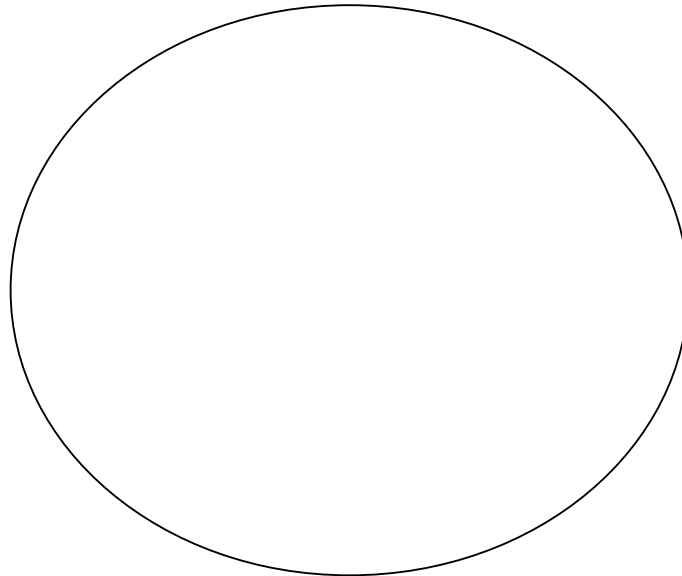
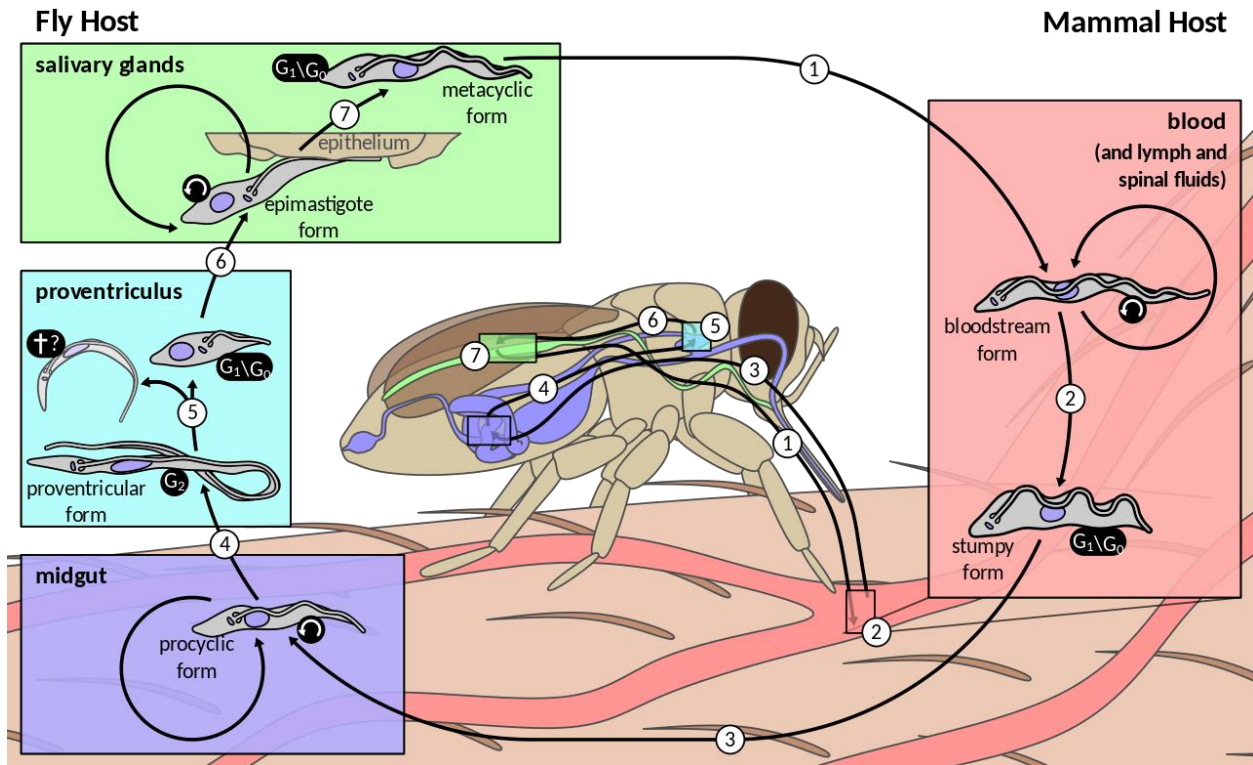

Figure of *Trypanosoma cruzi* life cycle. *T. cruzi* can also be transmitted through blood transfusions, organ transplantation, transplacentally, and in laboratory accidents. From CDC. Accessed 2018.

Trypanosoma brucei gambiense (trih-PAN-oh-soam-uh BRUCE-ee-eye gam-bee-EN-say). Draw at 1000x; notice the flagella attached to an undulating membrane.



Life cycle of *Trypanosoma brucei*. The cycle in the fly takes approximately 3 weeks. Humans are the main reservoir for *Trypanosoma brucei gambiense*, but this species can also be found in animals. Wild game animals are the main reservoir of *T. b. rhodesiense*. (OpenStax College Microbiology. Accessed 2018.)



Another life cycle of *Trypanosoma brucei*, focusing more attention on the vector. From Zephyris, Public domain, Wikipedia. 2016.

Trichomonas vaginalis (trick-oh-MOAN-us vah-gin-AL-iss). Draw at 1000x; try to find the multiple flagella, some attached to an undulating membrane.

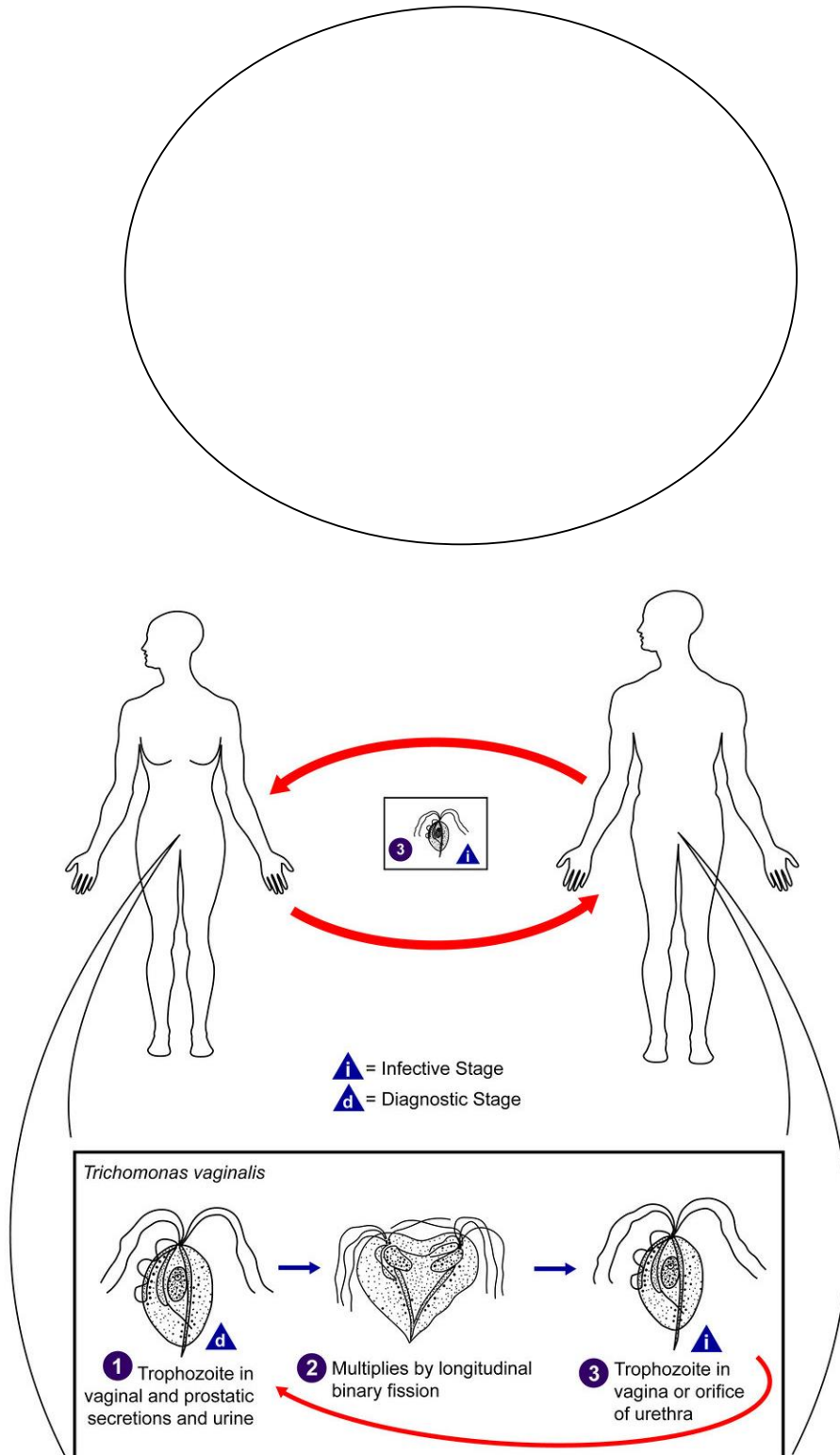

Figure of *Trichomonas vaginalis* life cycle from CDC/Alexander J. da Silva, PhD/Melanie Moser. Public Health Image Library. Accessed 2018.

Giardia lamblia (gee-ARR-dee-uh LAMB-lee-uh). This is a fecal smear; draw at 1000x; try to find the multiple flagella, and the adult nuclei that can look like eyes.

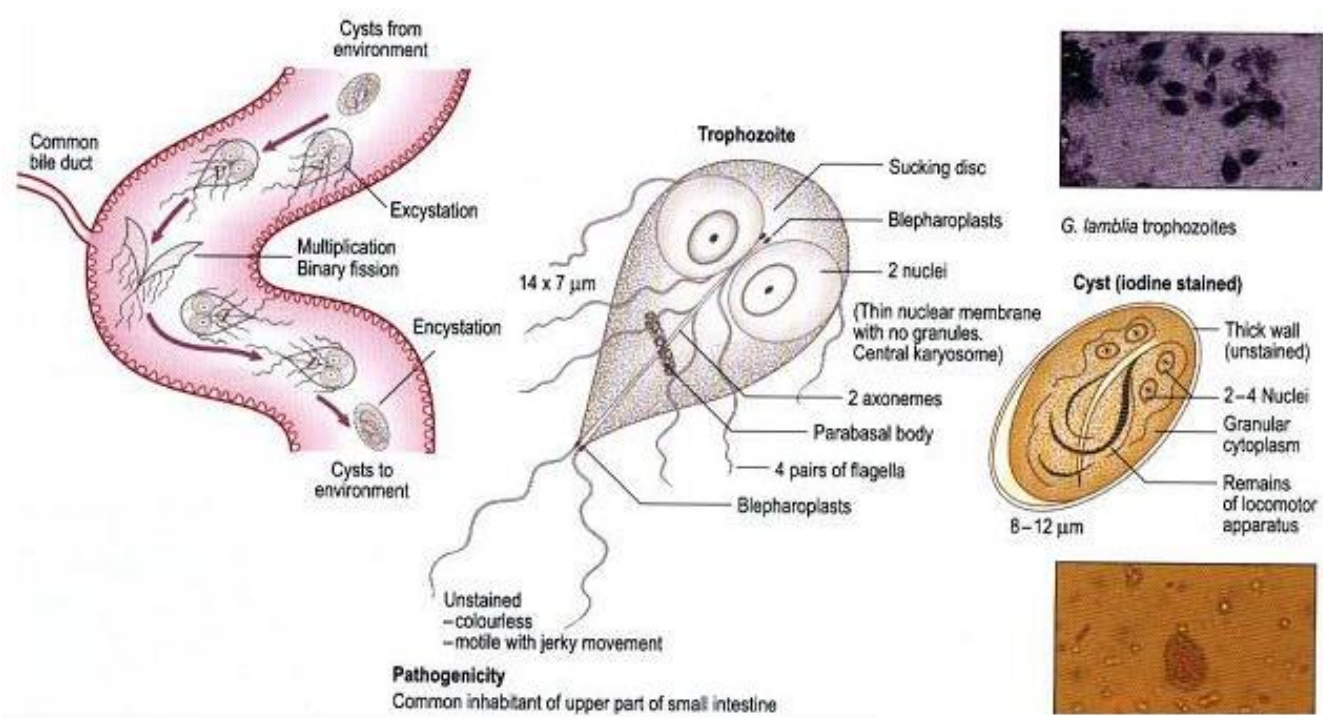
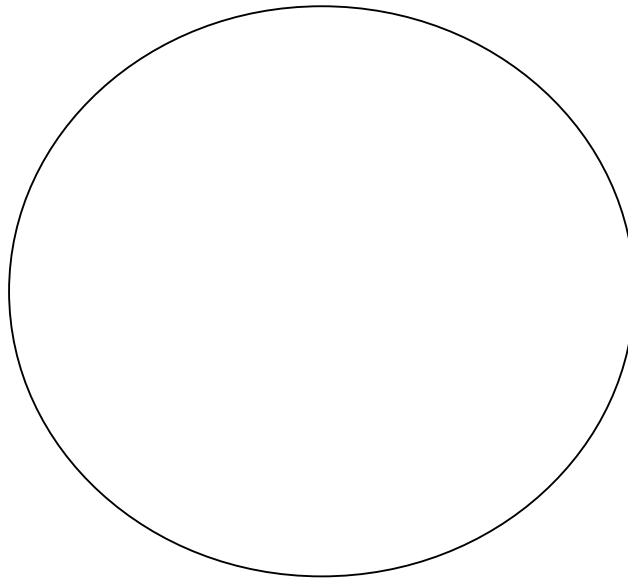

Figure of *Giardia lamblia* life cycle and morphology from Medical Laboratories website. www.medical-labs.net. Accessed 2018.

Leishmania donovani (lesh-MANE-ee-uh DAH-no-VAH-nee). Draw at 1000x; notice the flagella.

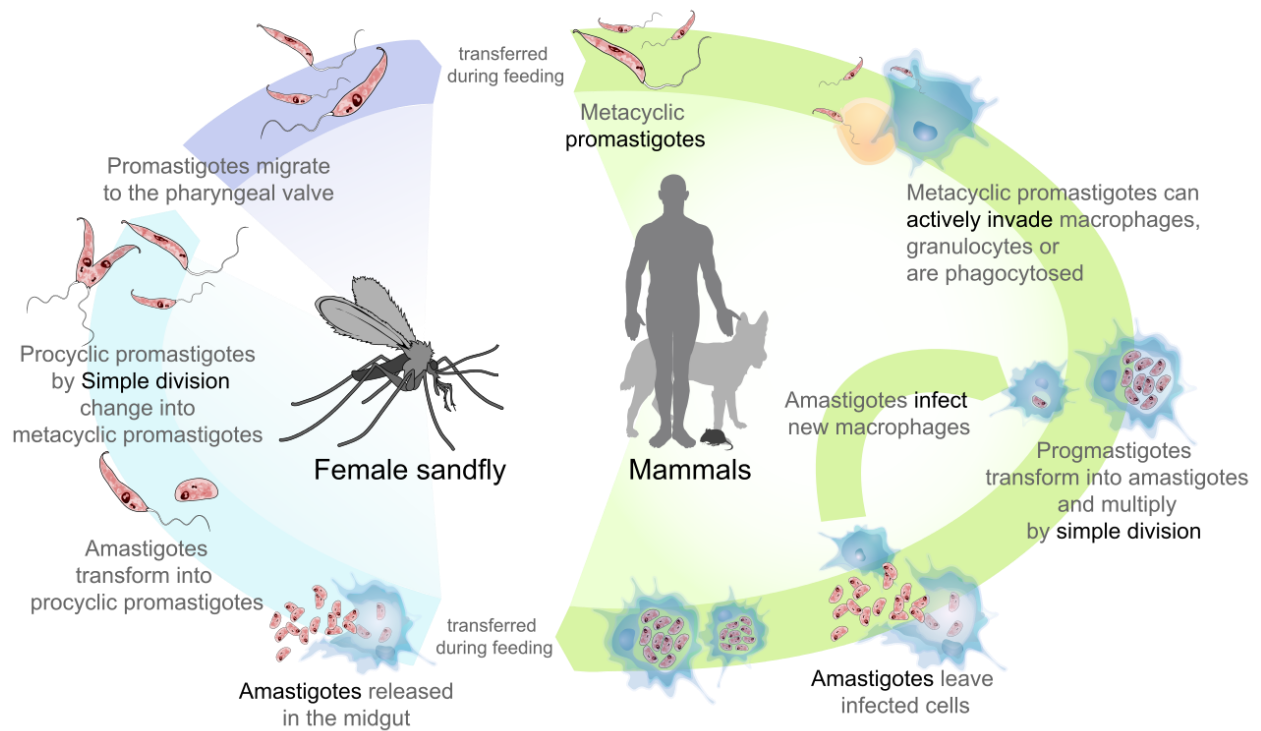
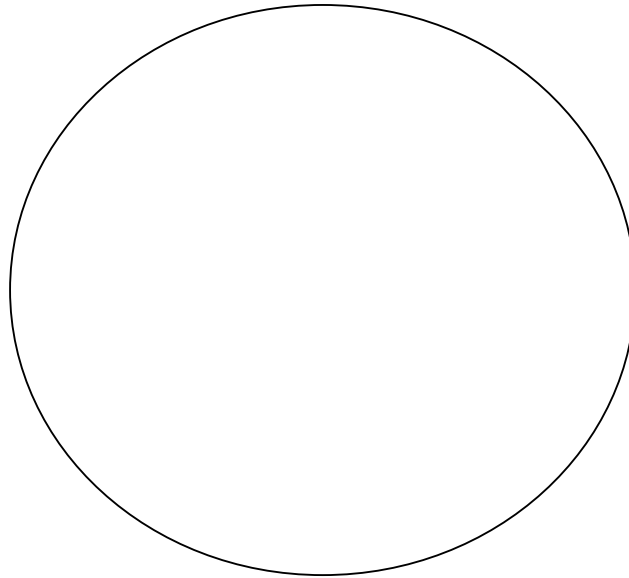
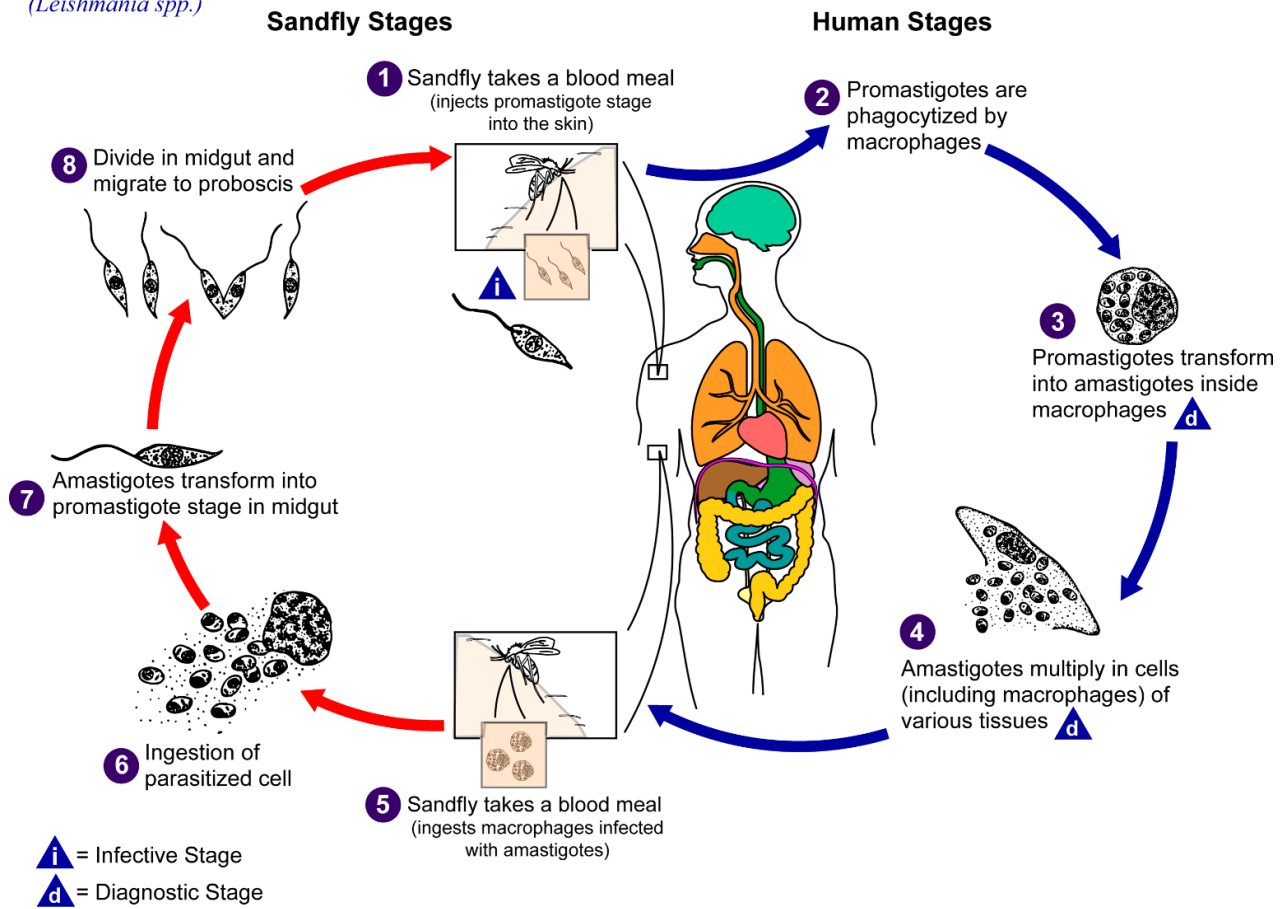

Figure of *Leishmania donovani* life cycle from LadyofHats, Public domain, Wikipedia. 2008.

Leishmaniasis

(*Leishmania spp.*)



Another life cycle of *Leishmania donovani* from CDC/Alexander J da Silva/Melanie Moser. Accessed 2018.

Plasmodium vivax (plaz-MOH-dee-um VYE-vax). Draw at 1000x; notice the ring stage.

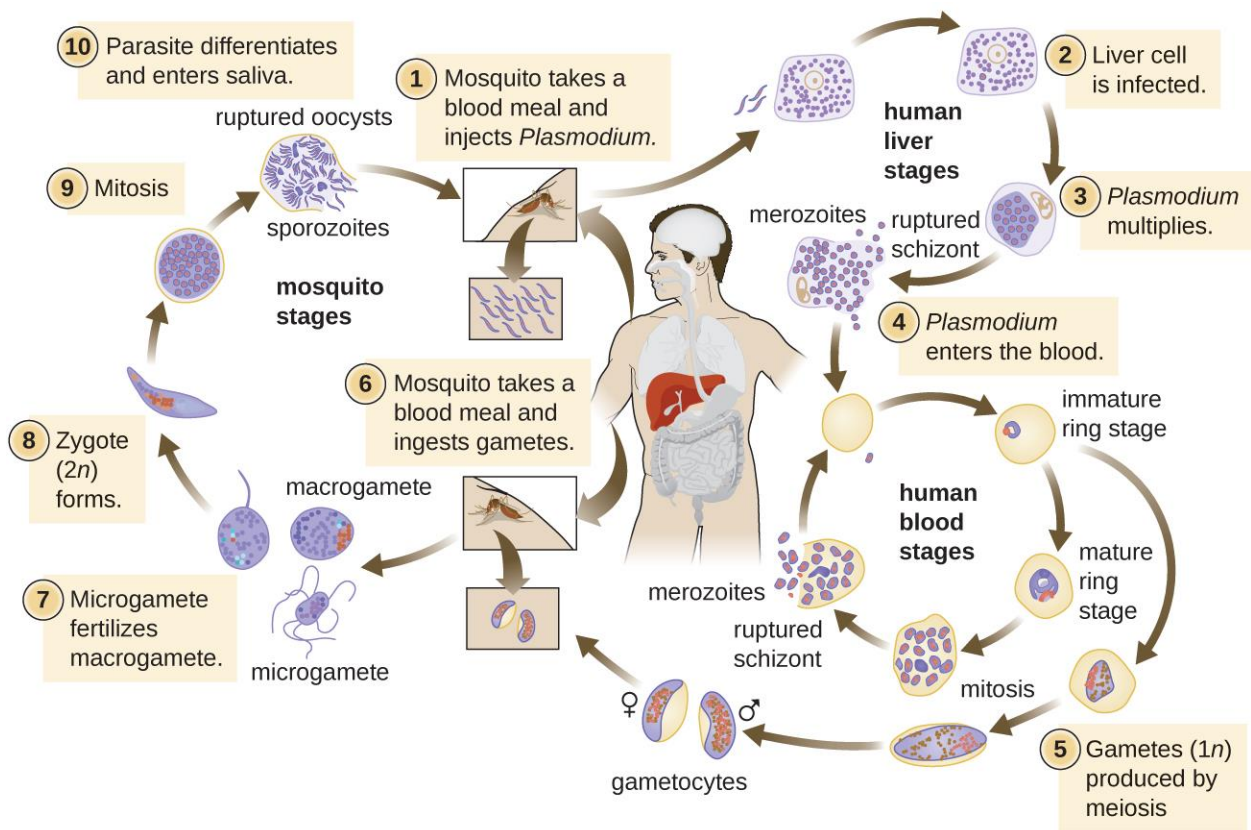
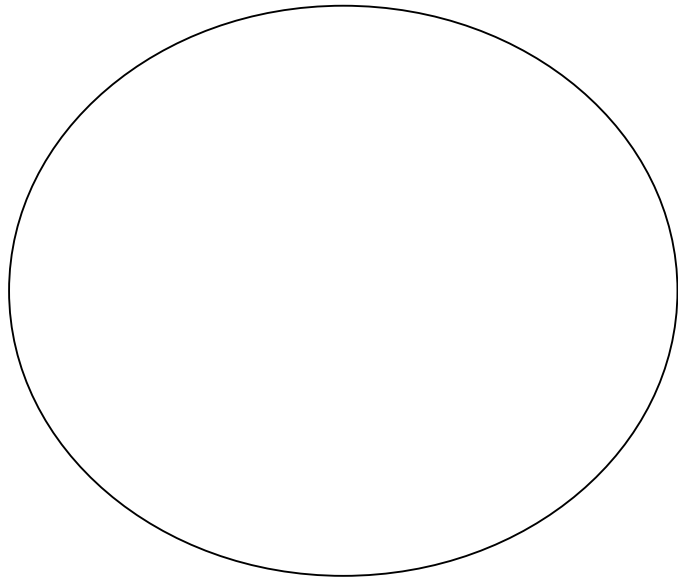
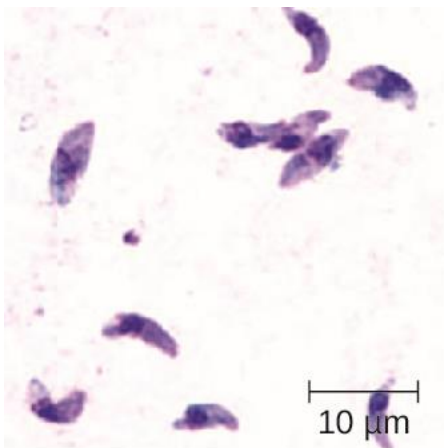
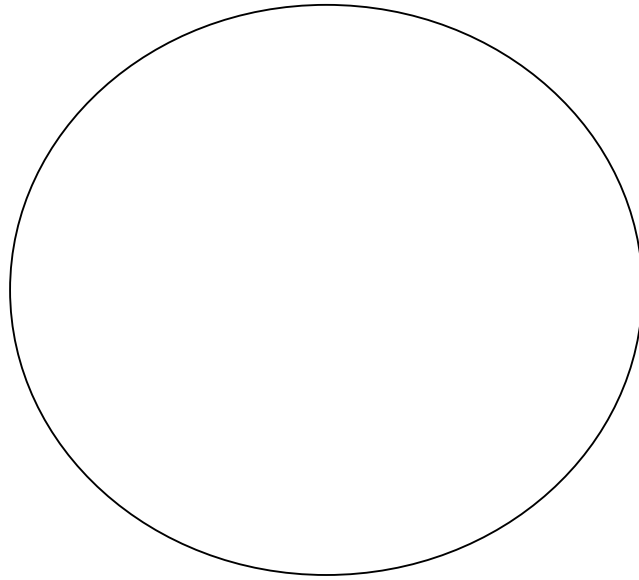

Figure of *Plasmodium* life cycle from OpenStax College Microbiology. Accessed 2018.



A blood smear (human blood stage) shows an early trophozoite in a delicate ring form (upper left) and an early stage schizont form (center) of *Plasmodium falciparum* from a patient with malaria. From OpenStax College Microbiology. Accessed 2018.

Toxoplasma gondii (TALKS-oh-plaz-muh GONE-dee-eye). Draw at 1000x; find the tachyzoites.



(a)

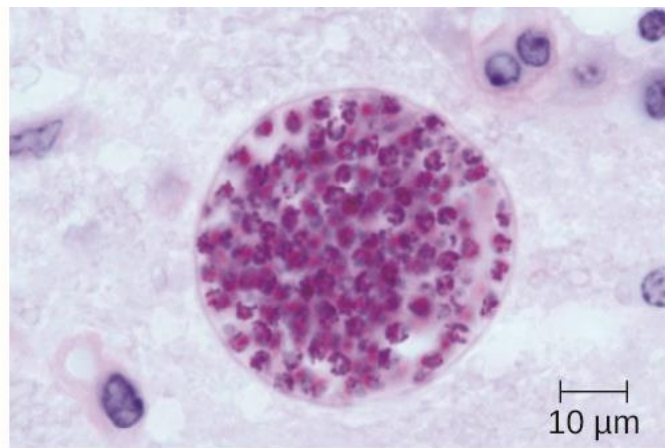

(b)

(a) Giemsa-stained *Toxoplasma gondii* tachyzoites from a smear of peritoneal fluid obtained from a mouse inoculated with *T. gondii*. Tachyzoites are typically crescent shaped with a prominent, centrally placed nucleus. (b) Microscopic cyst containing *T. gondii* from mouse brain tissue. Thousands of resting parasites (stained) are contained in a thin parasite cyst wall. From OpenStax College Microbiology. Accessed 2018.

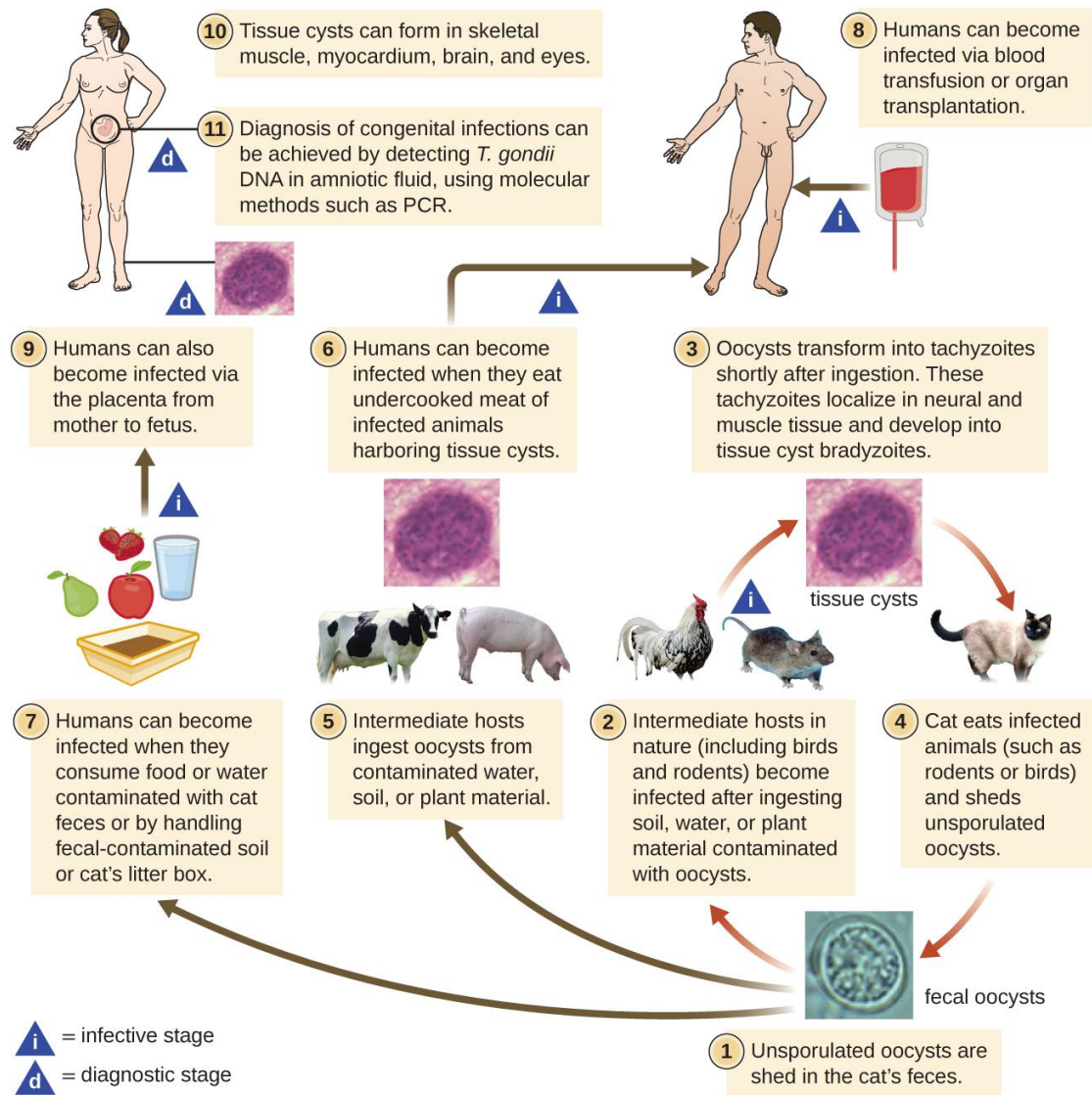
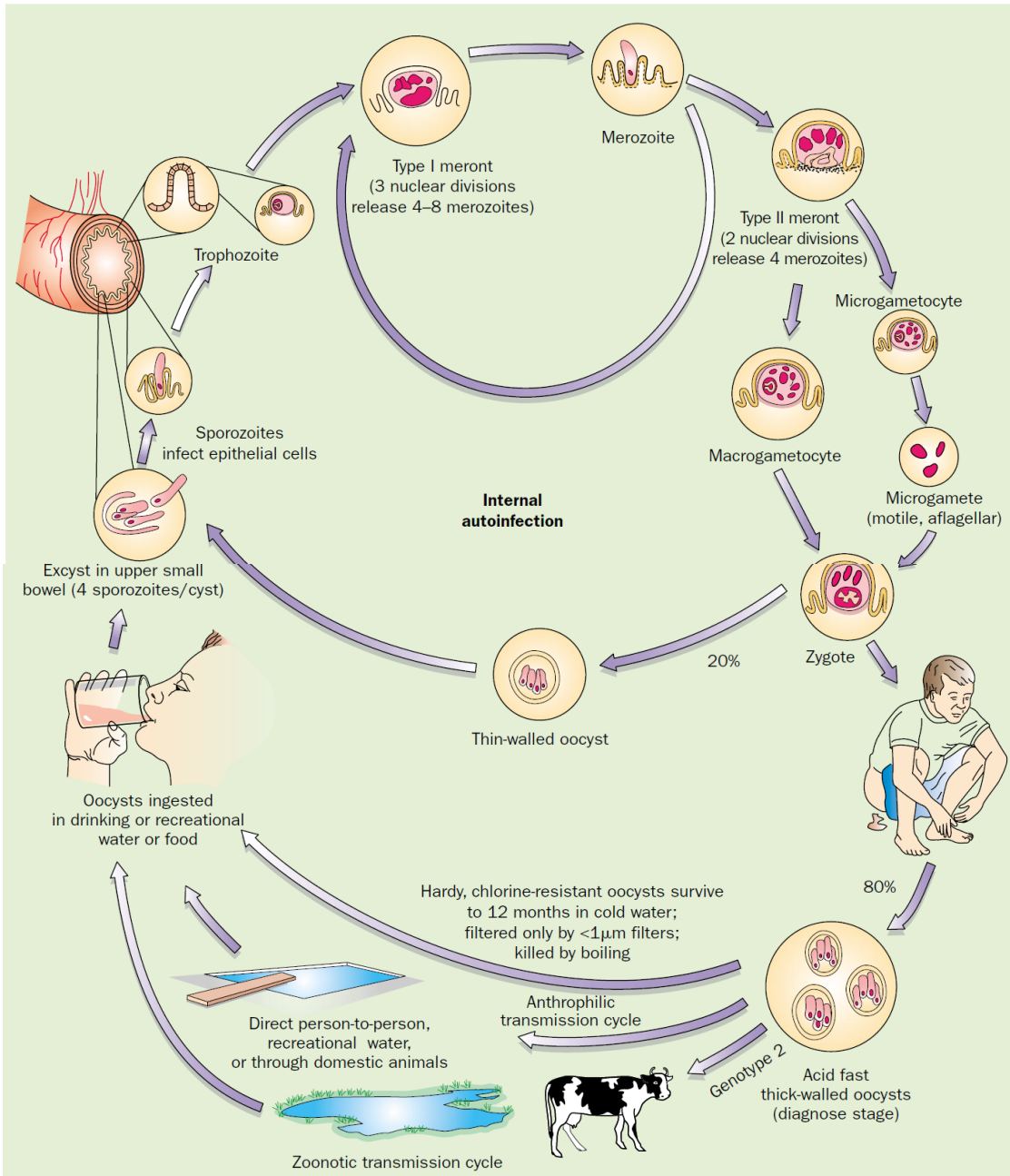
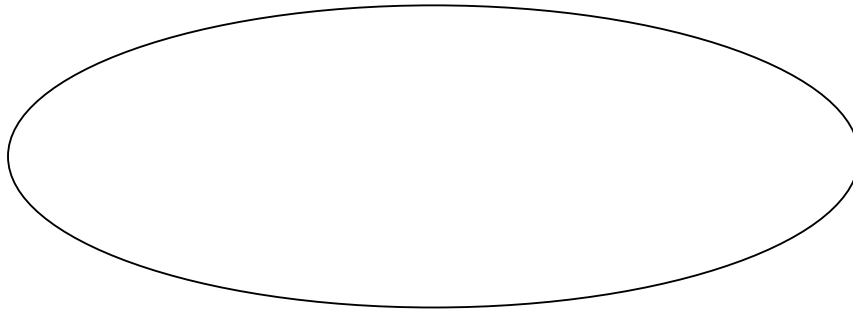

Figure of *Toxoplasma gondii* life cycle from OpenStax College Microbiology. Accessed 2018.

Cryptosporidium parvum (krip-toe-spoh-RID-ee-um PAR-vumm). Draw at 1000x; find the oocysts.



Cryptosporidium parvum life cycle from Kosek, et al. 2001. *Cryptosporidium*: an update. *The Lancet, Infectious Diseases*. 1: 262-269.

Review questions

Complete this table:

Species	Mode of motility	Disease in people	How transmitted to a person	Where found in human body	Other info (optional)
<i>Amoeba proteus</i>		none	n/a	n/a	
<i>Paramecium</i> sp.		none	n/a	n/a	
<i>Entamoeba histolytica</i>					
<i>Balantidium coli</i>					
<i>Trypanosoma cruzi</i>					
<i>Trypanosoma brucei gambiense</i>					
<i>Trichomonas vaginalis</i>					
<i>Giardia lamblia</i>					
<i>Leishmania donovani</i>					
<i>Plasmodium vivax</i>					
<i>Toxoplasma gondii</i>					
<i>Cryptosporidium parvum</i>					

Exercise 8: Parasitic Worms and Arthropod Vectors

Objectives

Compile information about several worms and arthropods, and learn to distinguish among them based on unique physical characteristics.

Introduction

Helminthes are parasitic worms that take resources from other living organisms. They are multicellular heterotrophs in the kingdom Animalia. There are two major phyla (a taxonomic grouping below the kingdom) that contain parasitic worms that are important to humans.

1. Phylum Platyhelminthes: These worms are commonly called flatworms because of their flat body structure. They do not have respiratory or circulatory structures, or a digestive tract, and thus rely on diffusion of nutrients and other chemicals. Two distinct types of Platyhelminthes exist: (a) trematodes, or flukes, and (b) cestodes, or tapeworms.
2. Phylum Nematoda (roundworms): These worms have more complex organ systems and are found in many types of habitats on Earth; a few species are parasitic to humans and other organisms.

Helminthes vary in their mode of transmission and the part of the body infected. Some are transmitted by cysts, eggs, or larval stages of development. Many parasitic worms infect the digestive tract but may be disseminated to other body parts as well. The severity of a parasitic worm infection varies with type of worm, number of individual organisms present, and whether or not they spread to other organs.

Arthropod vectors

Disease-causing organisms can be transmitted in many different ways. Some are transmitted by contaminated food or water, some by respiratory droplet, and some by sexual contact. Some pathogens are also transmitted to humans by vectors including insects (flies, mosquitoes) and arthropods (ticks, mites).

Vectors themselves are not microscopic organisms, but transmit microbes in one of two ways:

1. Mechanical vectors carry microbes on their body (e.g., a fly landing on your food).
2. Biological vectors carry microbes within their body, and will transmit to a new host via bite or sting (e.g., mosquito bite transmitting malaria; tick bite transmitting Lyme disease).

Diseases caused by vector-borne pathogens are difficult to control or eradicate because it would be necessary to kill all of the individual organisms that carry the pathogen. Disease prevention for vector-borne pathogens include the use of insecticides and insect repellents (which pose their own health risks), avoiding contact with the vector by using mosquito netting, or avoiding being outside in areas when/where the vector is most active.

In this lab you will observe a few common arthropod vectors. Arthropods have a segmented exoskeleton and jointed appendages. The medically-important arthropods include two classes: Class Insecta, whose adults have six legs (such as fleas, flies, lice, and mosquitoes), and Class Arachnida, whose adults have eight legs (such as spiders, ticks, and mites).

Define the following terms:

- Larval stage of parasite:
- Intermediate host:
- Definitive host:
- Dioecious:
- Monoecious / hermaphroditic:
- Fluke:
- Scolex of tapeworm:
- Proglottid of tapeworm:
- Vector:

Materials

- *Taenia saginata*
- *Clonorchis sinensis*
- *Fasciola hepatica*
- *Schistosoma haematobium*
- *Ascaris lumbricoides*
- *Necator americanus*
- *Enterobius vermicularis*
- *Trichinella spiralis*
- *Wuchereria bancrofti*
- *Toxocara canis*
- *Pediculus humanus* ssp.
- Flea
- Tick
- Mosquito

Instructions Observe the following slides and preserved specimens. Use the spaces provided to draw diagrams that will help you remember the organism.

Flatworms

Taenia saginata (tae-KNEE-uh sa-gin-AH-ta). Label the adult scolex, suckers, and proglottids.

Life-size drawing:

Magnified drawing:

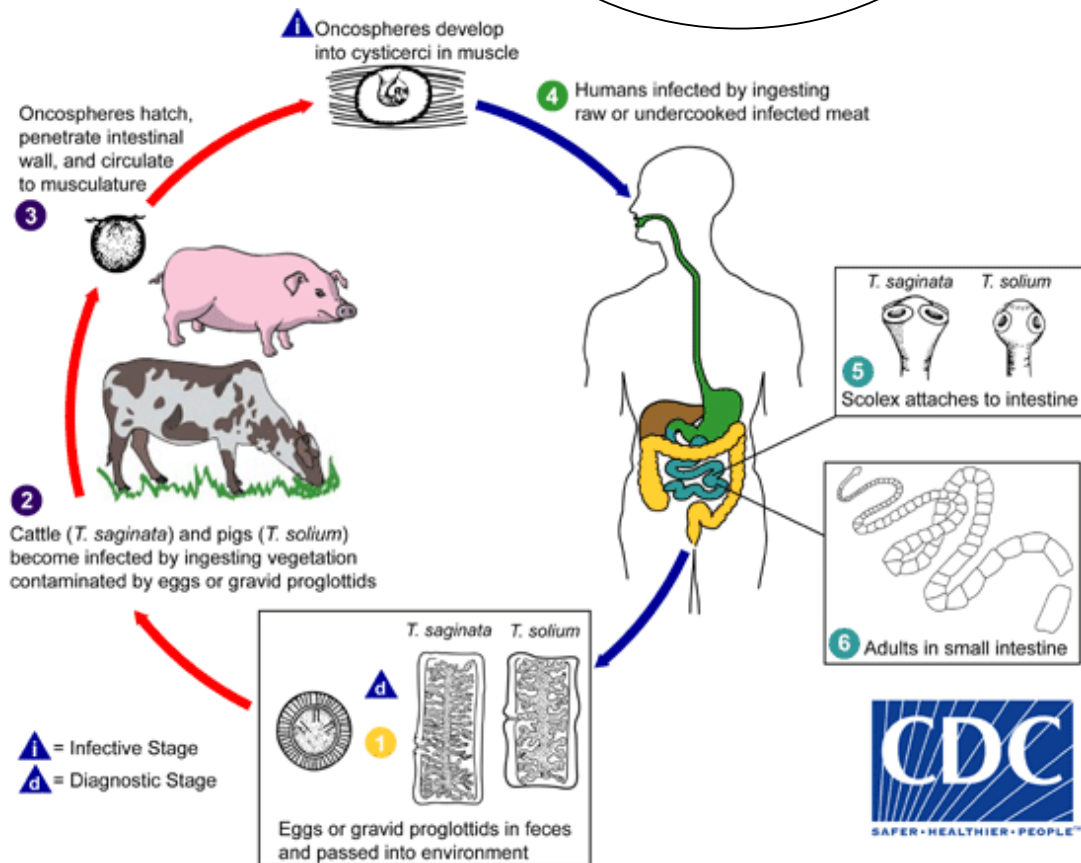
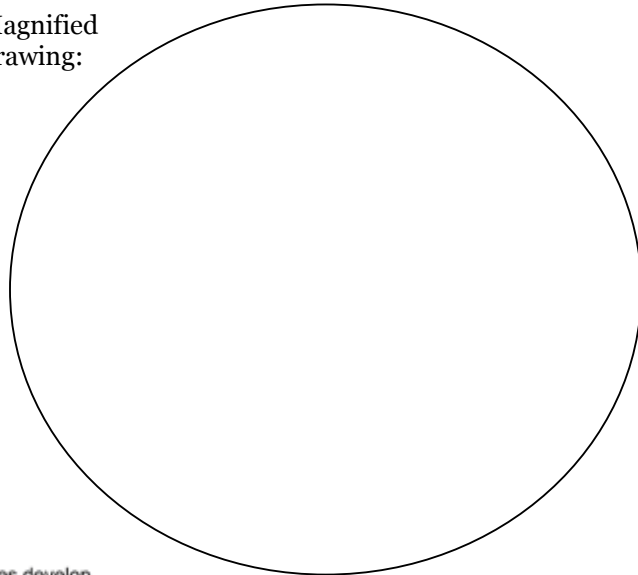

Image of *Taenia saginata* life cycle from CDC.

Clonorchis sinensis (clon-OR-kiss sin-EN-sis). Find and label the adult oral sucker, ventral sucker/acetabulum, uterus, and testes. Notice the shape and size compared with *Fasciola*.

Life-size drawing:

Magnified drawing:

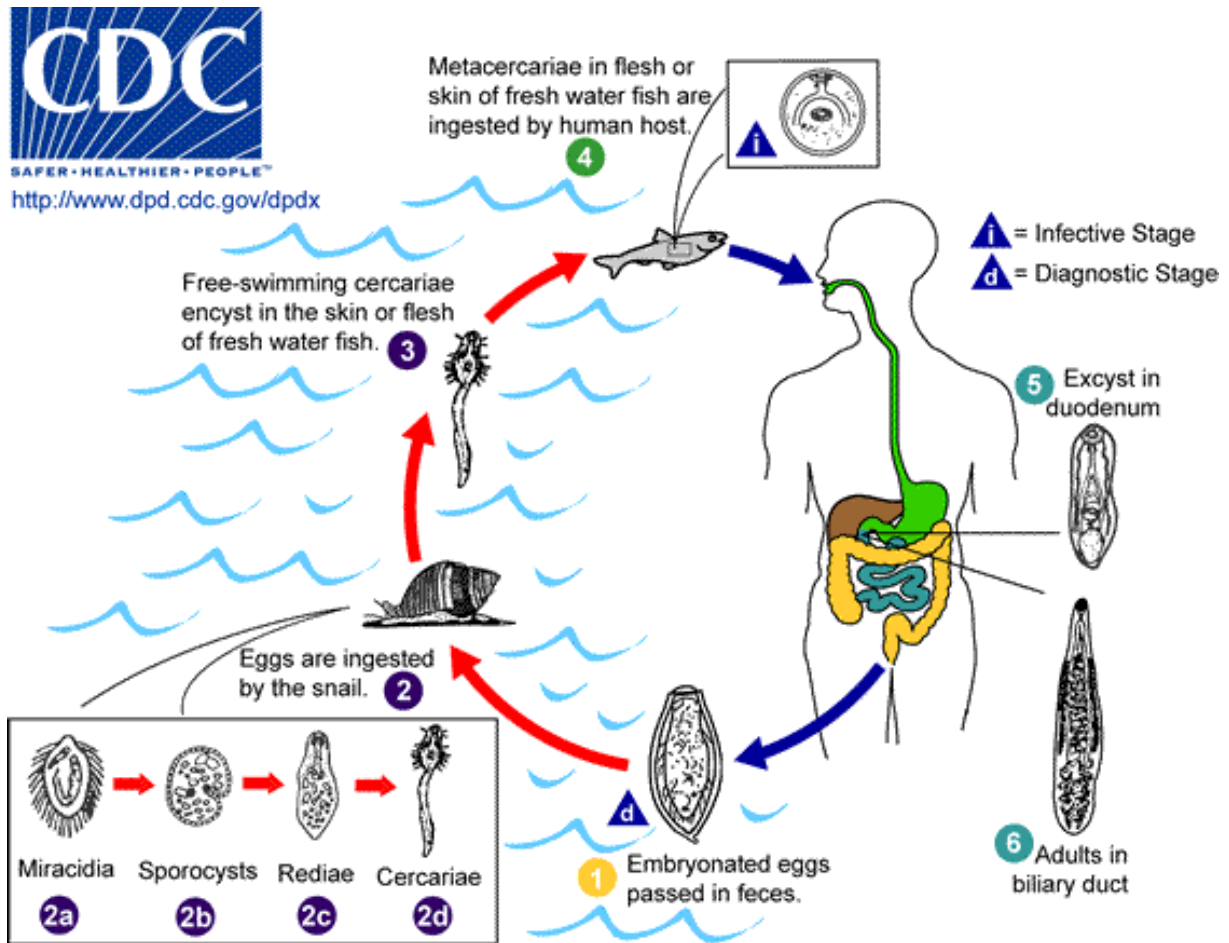
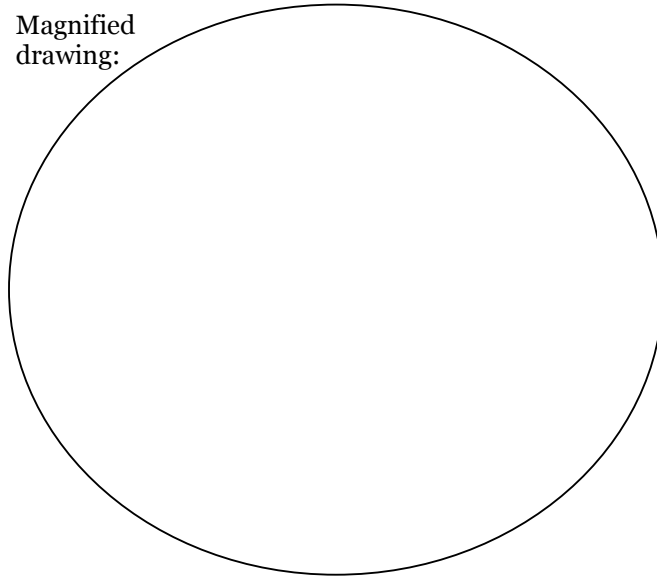

Figure of *Clonorchis sinensis* life cycle from CDC.

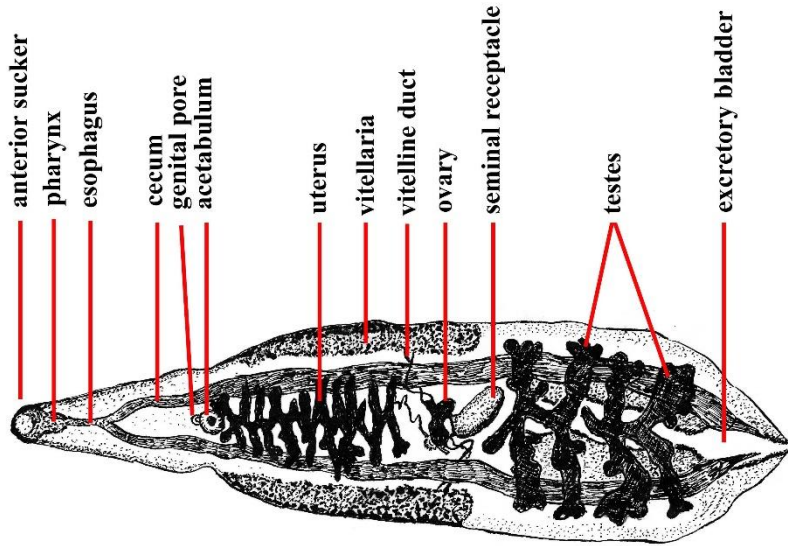

Figure of *Clonorchis sinensis* from Jarrod Wood, Animal Parasitology, Biology 265. Kansas State University. Accessed 2018.

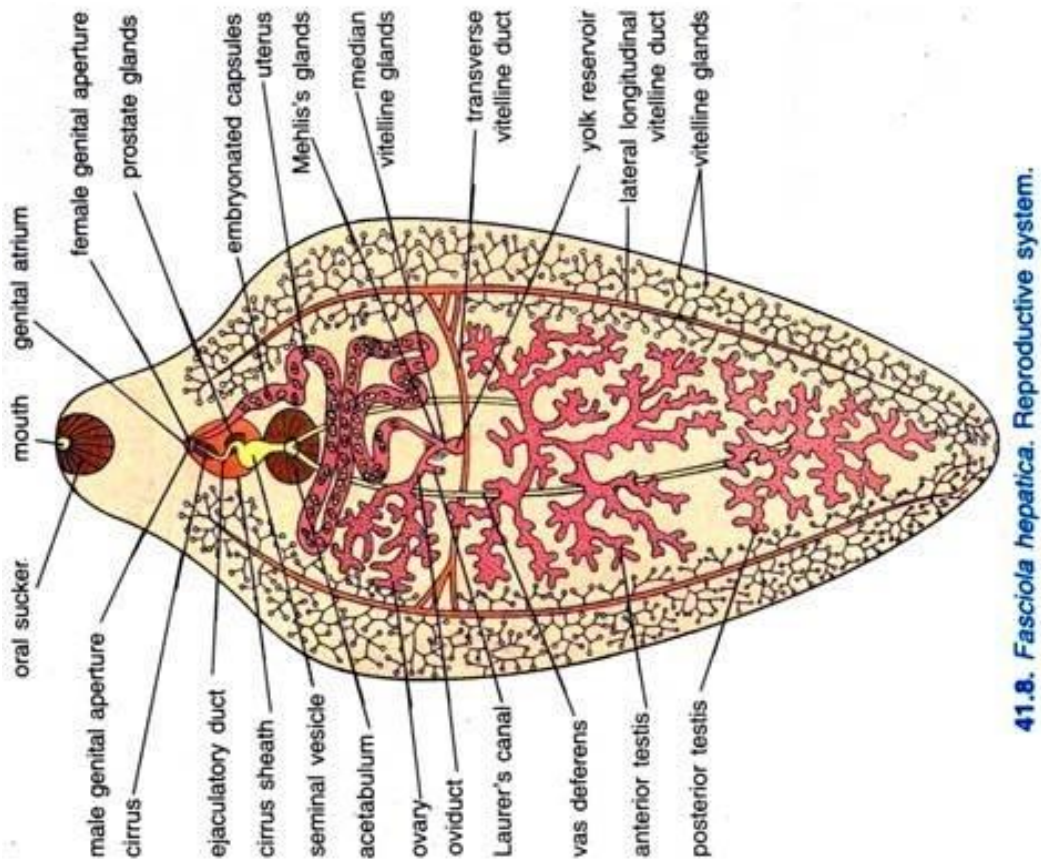

Diagram of *Fasciola hepatica* anatomy from Richa Shah, BiologyDiscussion.com. Accessed 2018.

Fasciola hepatica (fash-ee-OL-uh hih-PAT-ih-kuh). Label the adult oral sucker, ventral sucker/acetabulum, ovary, and testes. Notice the shape and size compared with *Clonorchis*.

Life-size drawing:

Magnified drawing:

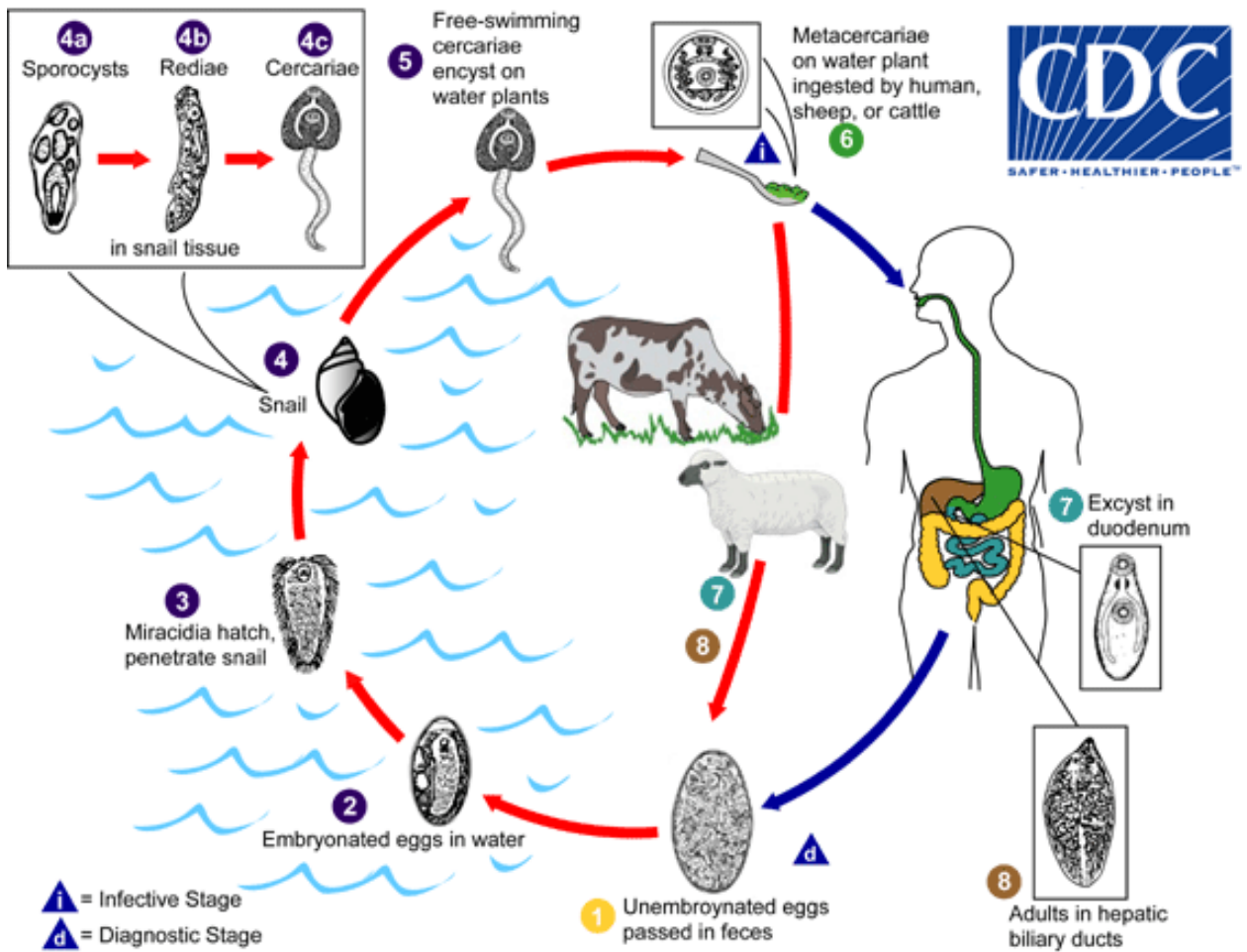
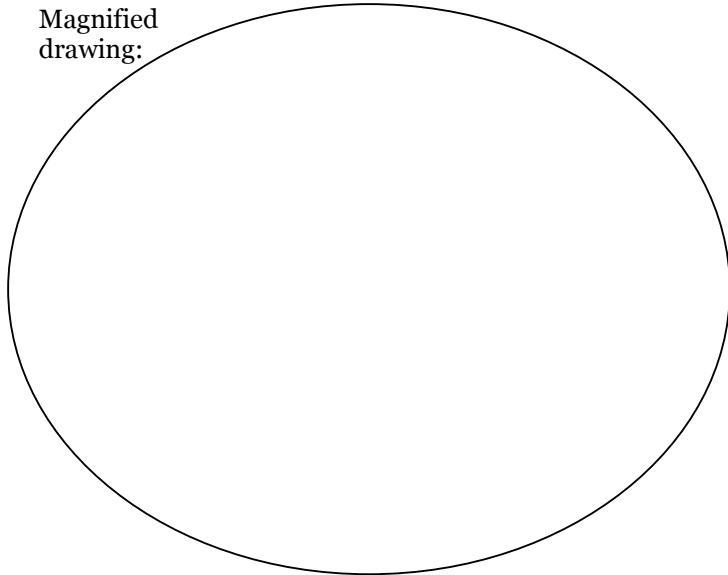
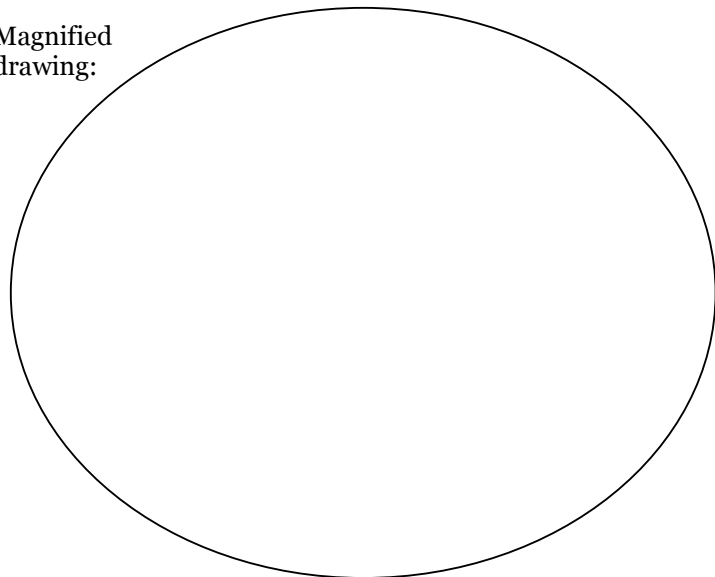

Figure of *Fasciola hepatica* life cycle from CDC.

Schistosoma haematobium (shiss-toe-SO-muh hee-muh-TOE-bee-um). Find and label the gynecophoric groove in the adult male. Notice the male and female arrangement.

Life-size drawing:

Magnified drawing:



Schistosome Life Cycle & Transmission

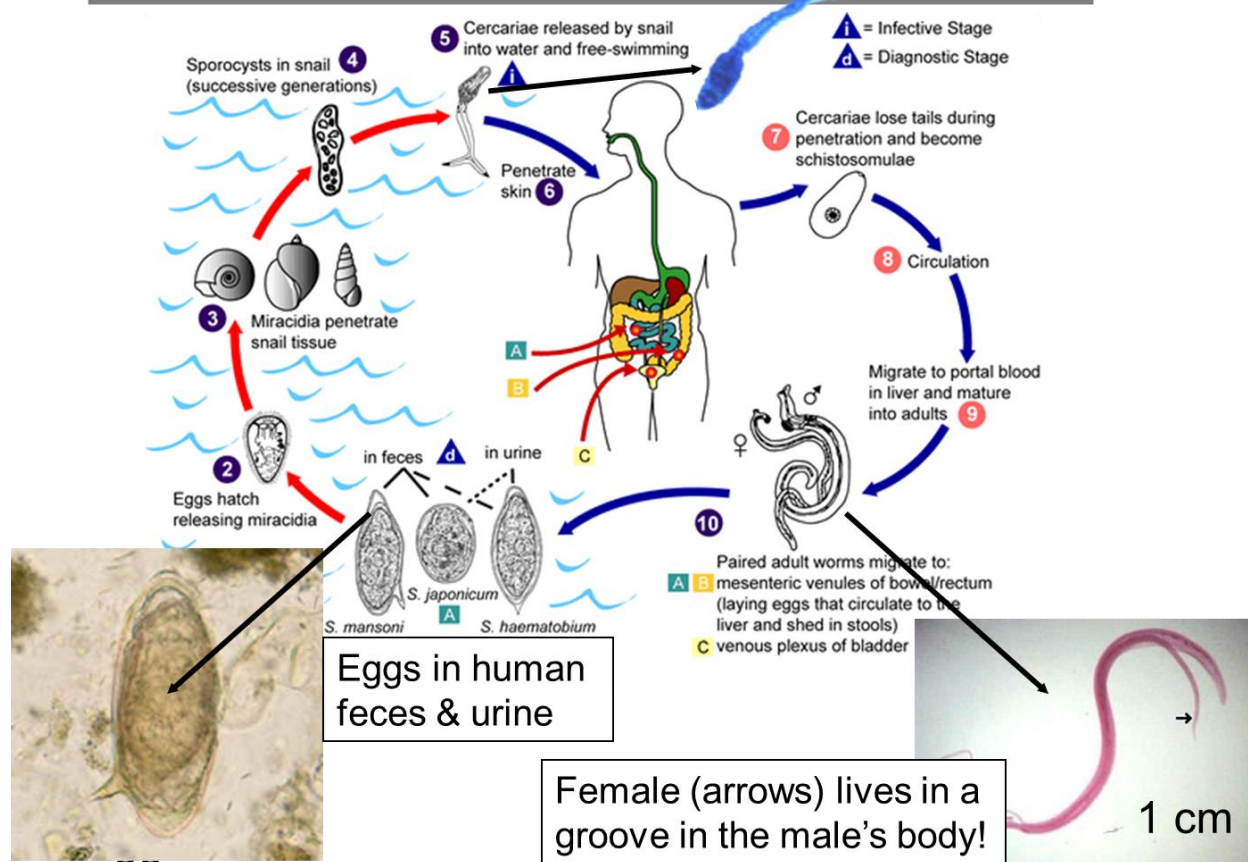

Figure of *Schistosoma* life cycle from Wayne W. LaMorte, 2016. Animal-related Infection. Boston University School of Public Health. Accessed 2018.

Roundworms

Ascaris lumbricoides (ASS-car-iss lum-brick-OY-dees). Observe the adults. Notice the size, and label the male vs. female tail shape.

Life-size drawing:

Magnified
drawing:

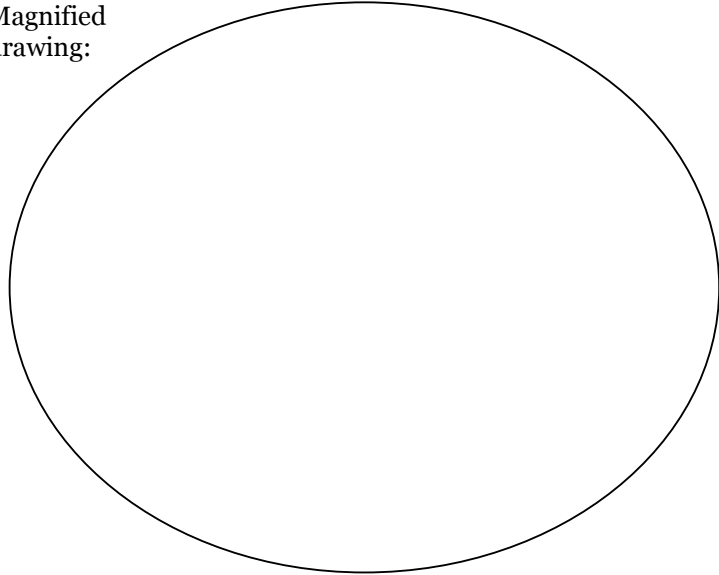

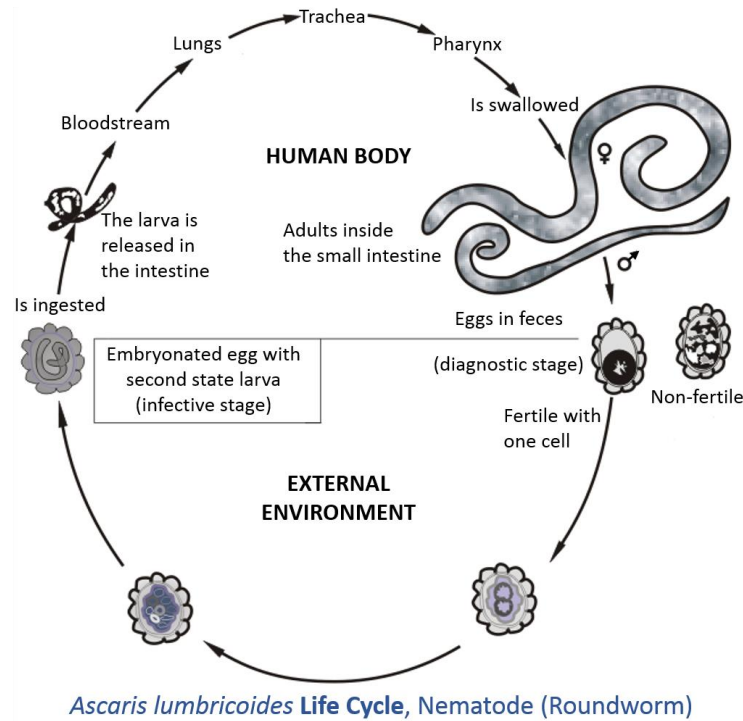

Figure of *Ascaris lumbricoides* life cycle from Wikimedia Commons. commons.wikimedia.org. Accessed 2018.



(a)



(b)

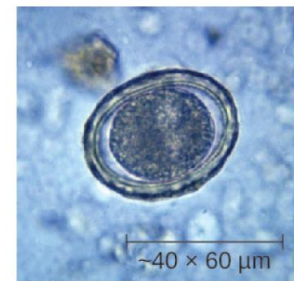

(c)

(a) Adult *Ascaris lumbricoides* roundworms can cause intestinal blockage. (b) This mass of *A. lumbricoides* worms was excreted by a child. (c) A micrograph of a fertilized egg of *A. lumbricoides*. Fertilized eggs can be distinguished from unfertilized eggs because they are round rather than elongated and have a thicker cell wall. (credit a: modification of work by South African Medical Research Council; credit b: modification of work by James Gathany, Centers for Disease Control and Prevention; credit c: modification of work by Centers for Disease Control and Prevention) From OpenStax Microbiology.

Necator americanus (neh-CAY-tur uh-MER-ih-CAN-iss). Observe the adult. Notice the size and shape.

Life-size drawing:

Magnified drawing:

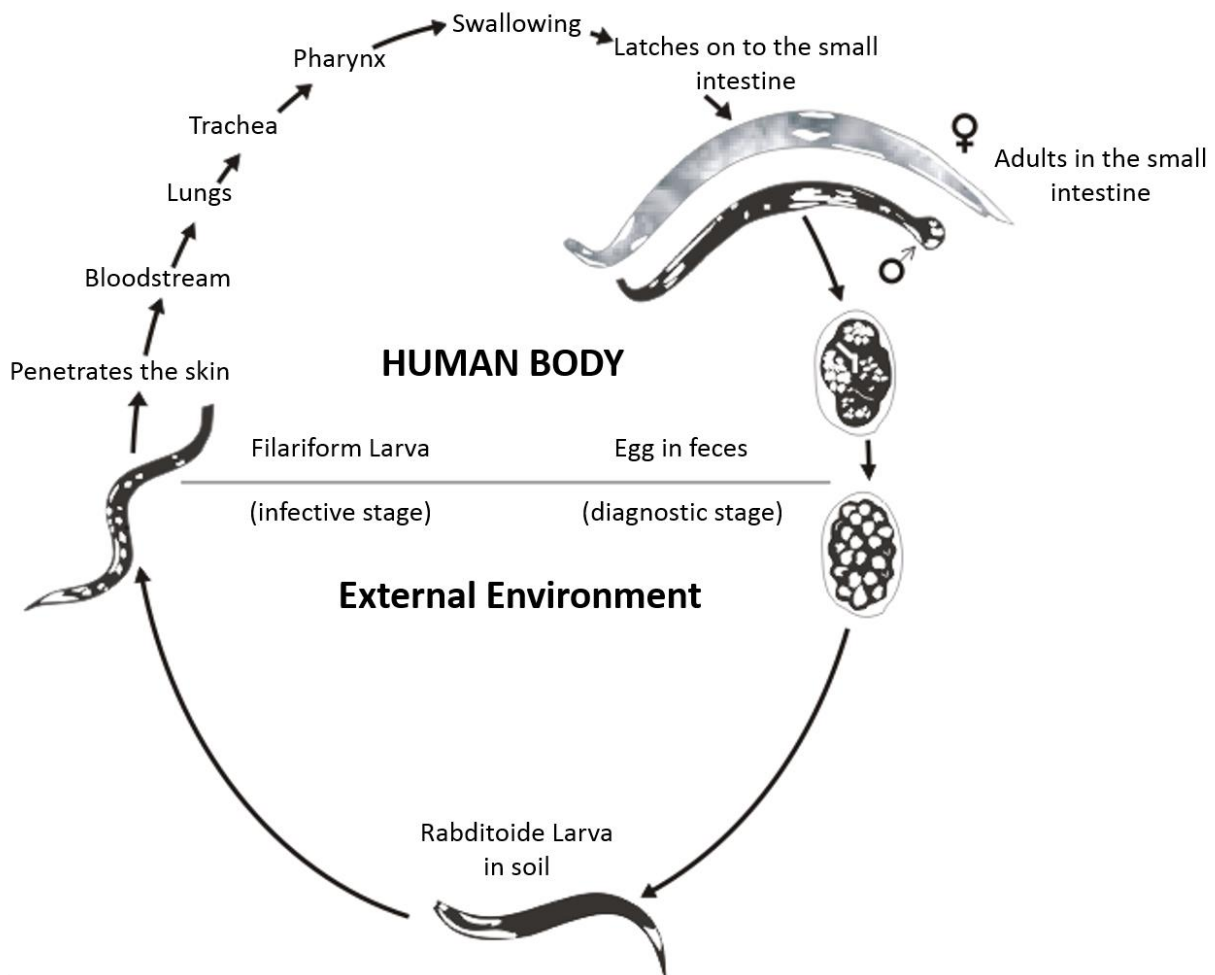
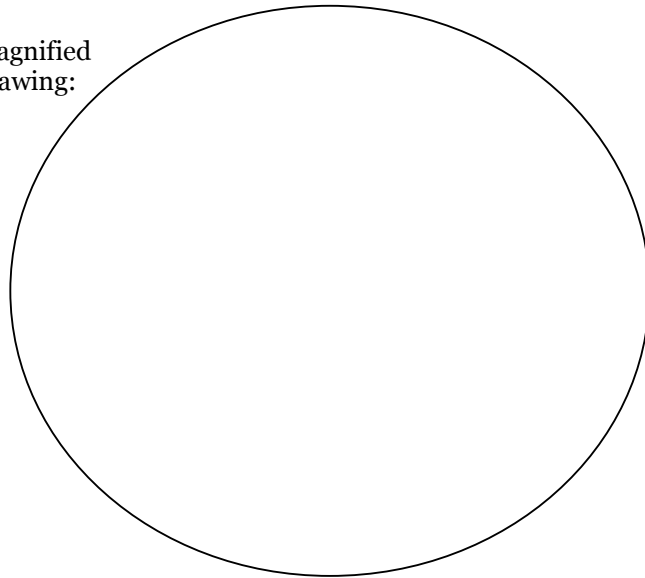

***Necator americanus* Life Cycle, Nematode (Hookworm)**

Figure of *Necator americanus* life cycle from Wikimedia Commons. commons.wikimedia.org. Accessed 2018.

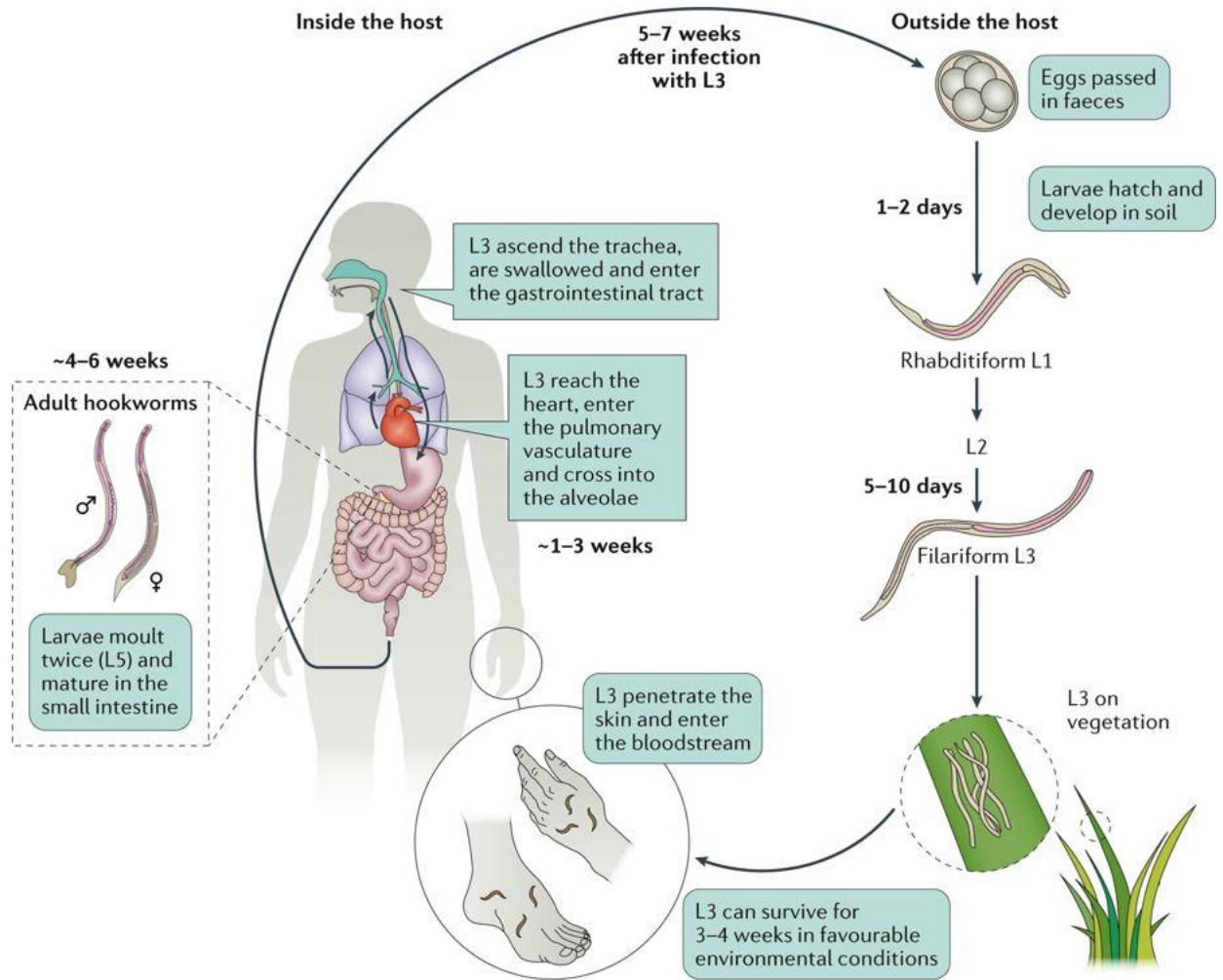

Nature Reviews | Disease Primers

Another figure of *Necator americanus* life cycle from A. Loukas et al. 2016. Hookworm infection. Nature Reviews Disease Primers 2: article 16088. Accessed 2018.

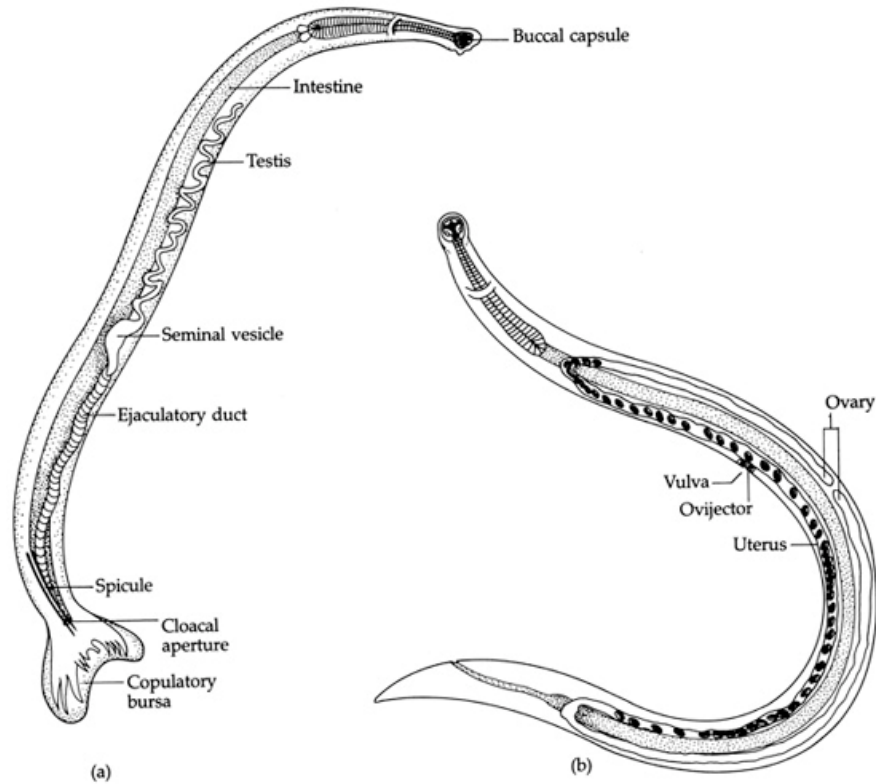

Figure of *Necator americanus* anatomy, (a) male, (b) female. From Wayne W. LaMorte. 2016. *Animal-related Infection*. Boston University School of Public Health. Accessed 2018.

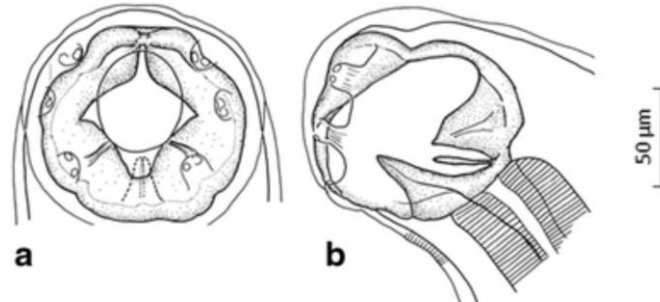
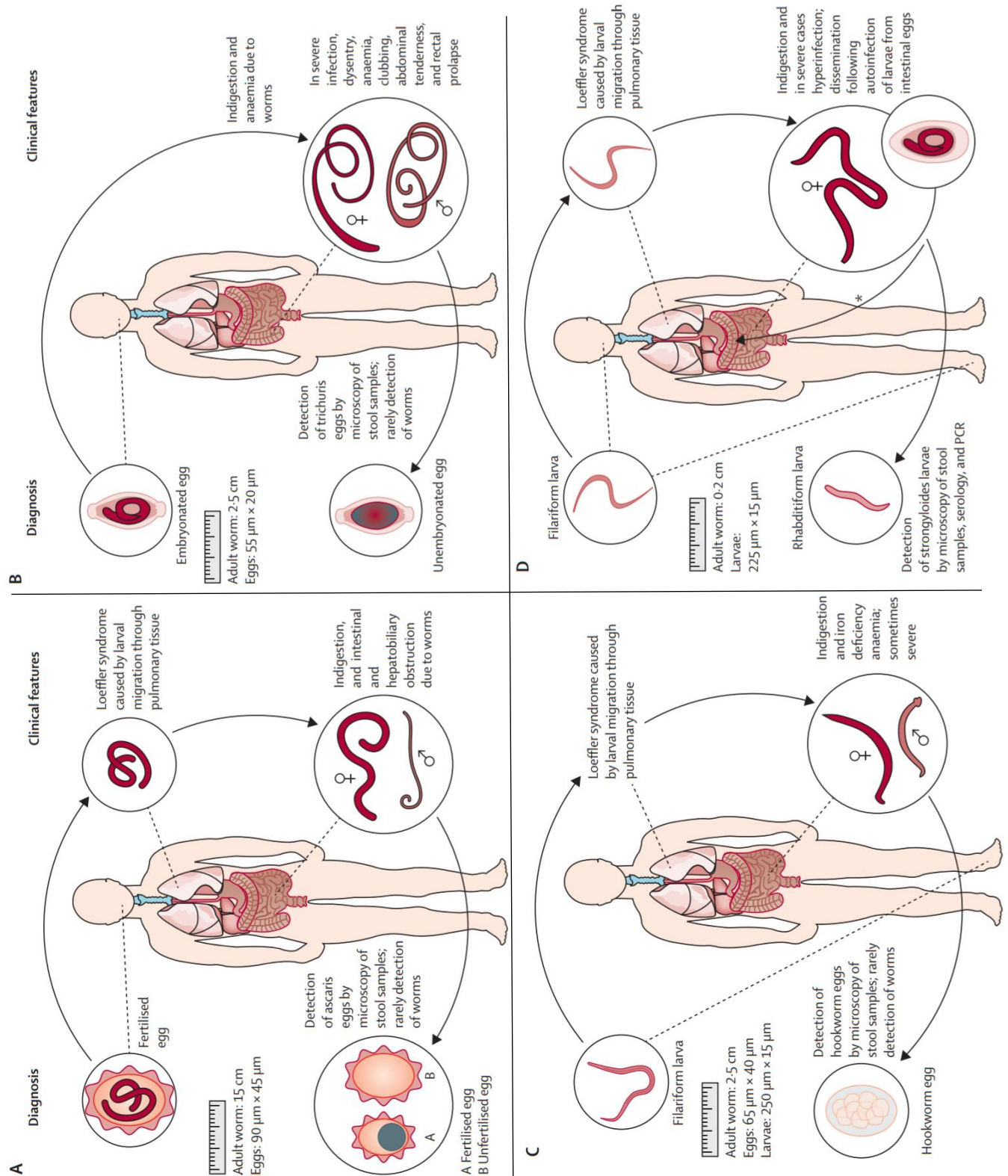

Figure of *Necator americanus* buccal capsule (a, b) from B. Kalousova et al. 2016. Adult hookworms (*Necator* spp.) collected from researchers working with wild western lowland gorillas. *Parasites & Vectors* 9:75.



Photo of *Necator americanus* buccal capsule with two cutting plates visible, from J. C. Fox. *Veterinary Clinical Parasitology Images*. Oklahoma State University College of Veterinary Medicine. Accessed 2018.



Transmission of *Ascaris lumbricoides* (A), *Trichuris trichiura* (B), hookworm (*Ancylostoma duodenale* and *Necator americanus*; C), and *Strongyloides stercoralis* (D). * Arrow indicates autoinfection. Figure from P. M. Jourdan et al. 2018. Soil-transmitted helminth infections. *Lancet* 391: 252-65.

Enterobius vermicularis (en-ter-OH-bee-us ver-mih-kew-LAIR-iss). Observe the adults. Notice and label the male vs. female size and tail shape.

Life-size drawing:

Magnified drawing:

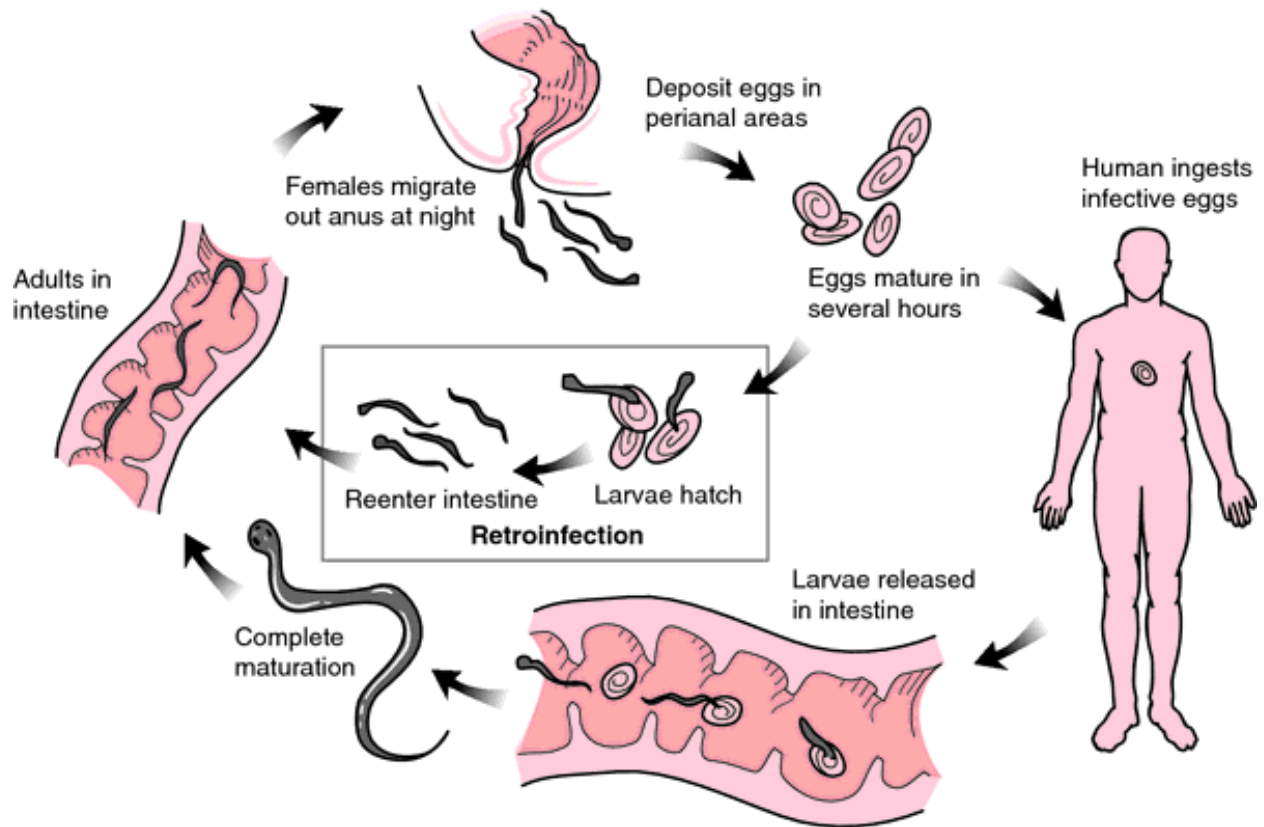
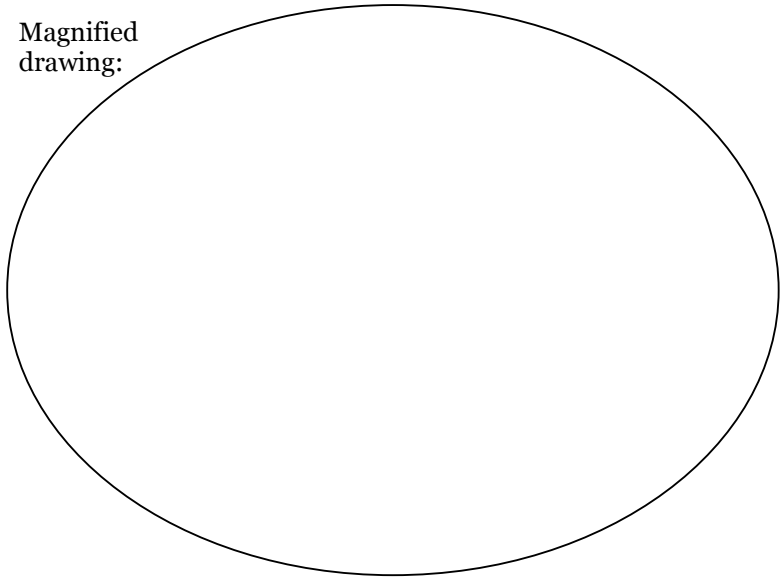

When the eggs are deposited in the perianal area, the skin is often irritated and itchy. People scratch, often subconsciously at night, and eggs lodge under fingernails, and are easily ingested. Figure of *Enterobius vermicularis* life cycle from Mahon and Manuselis. 2000.

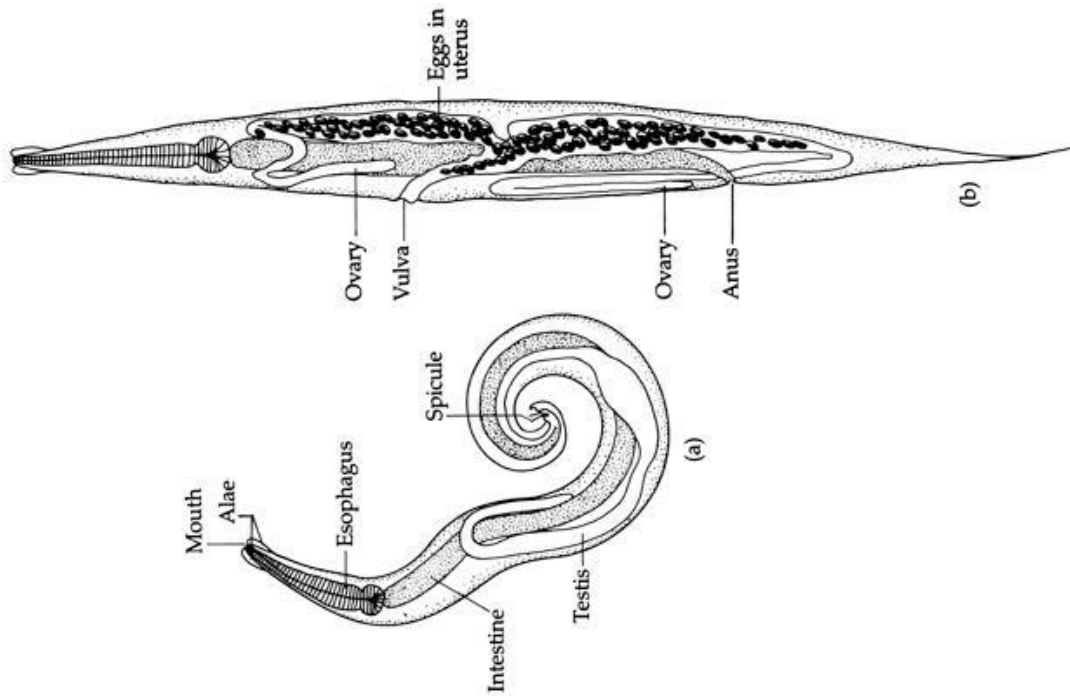
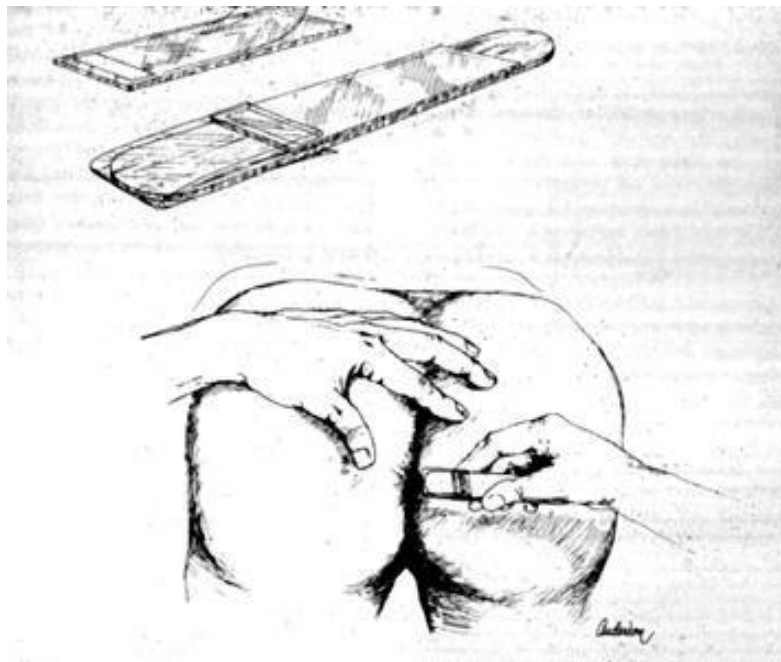

Figure of *Enterobius vermicularis* male (a) and female (b) from C. Church. Parasitology, Biology 3270. Metropolitan State University of Denver. Accessed 2018.



This figure shows a tape test to detect an infection. The best time to do this is in the morning before bathing, because pinworms lay their eggs at night. Steps for the test are to firmly press the sticky side of a strip of cellophane tape over the anal area for a few seconds. The eggs stick to the tape. The tape is then transferred to a glass slide, sticky side down (medlineplus.gov). Figure of tape test for diagnosing pinworm infection, from C. Yang. 2007. *Enterobius vermicularis*. Stanford University. Accessed 2018.

Trichinella spiralis (trick-ih-NELL-uh spy-RALL-iss). Find the larvae, and note their appearance in muscle.

Life-size drawing:

Magnified drawing:

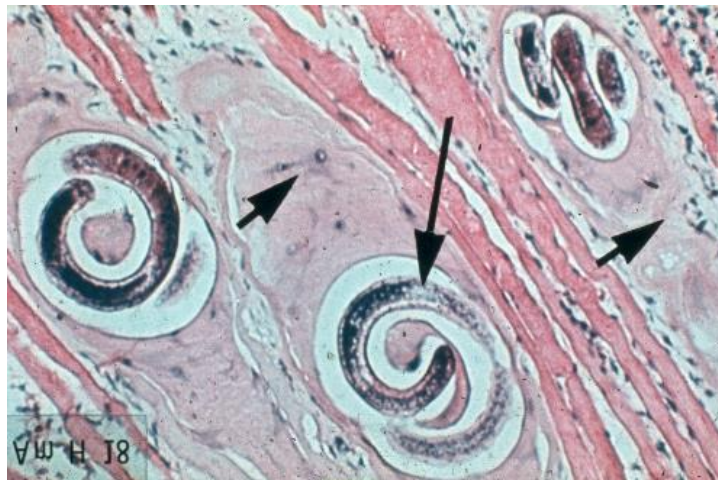
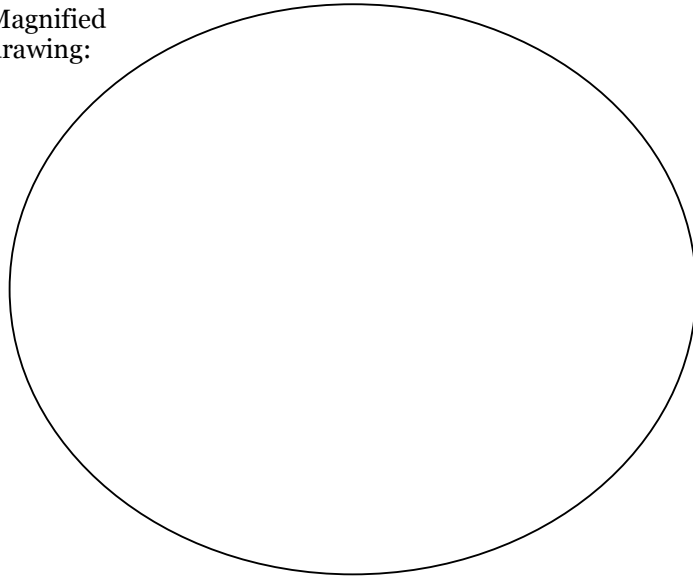

Figure of *Trichinella spiralis* in polar bear muscle tissue, at large arrow. From The Royal (Dick) School of Veterinary Studies. 2007. University of Edinburgh. Accessed 2018.

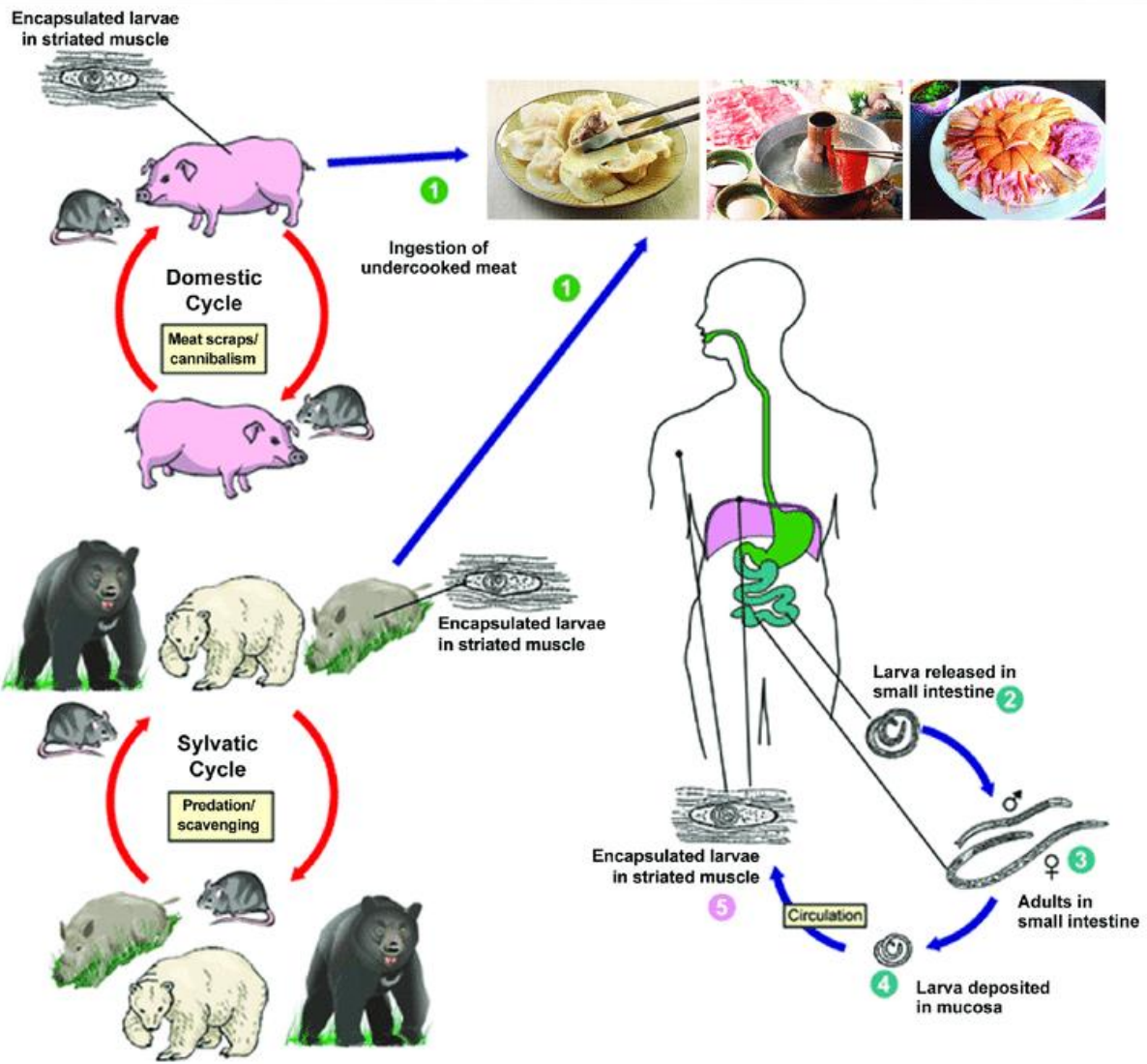

Figure of *Trichinella spiralis* life cycle from CDC and X. Bai, et al. 2017. Current Research of Trichinellosis in China. *Frontiers in Microbiology* 8: article 1472. Accessed 2018.

Wuchereria bancrofti (WOO-ker-AIR-ee-uh bang-KROFT-ee). Find the larvae, and notice their size.

Life-size drawing:

Magnified drawing:

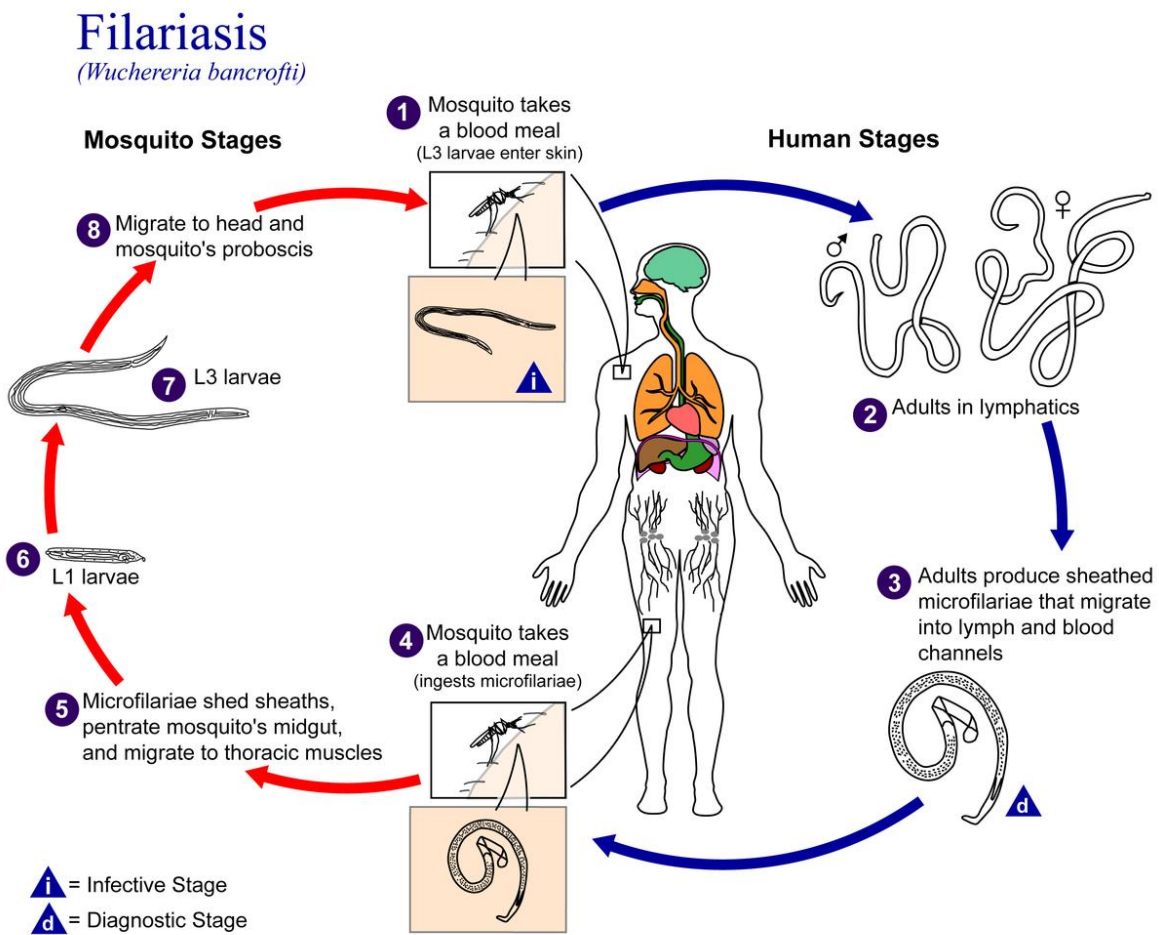
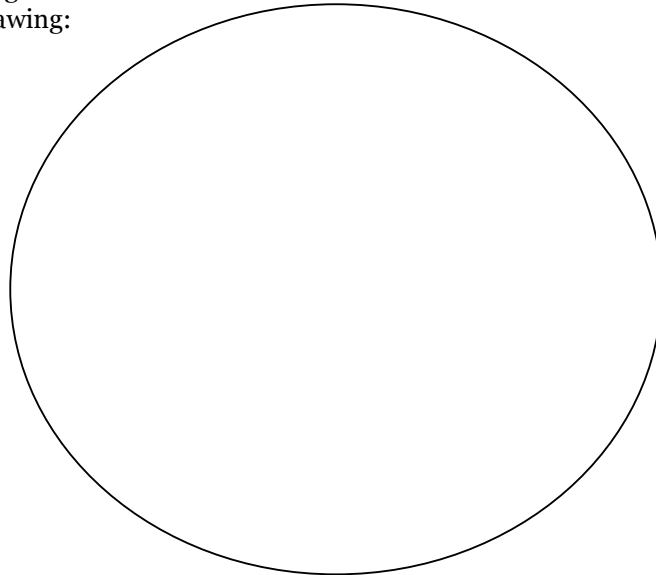

Figure of *Wuchereria bancrofti* life cycle from CDC. Accessed 2018.

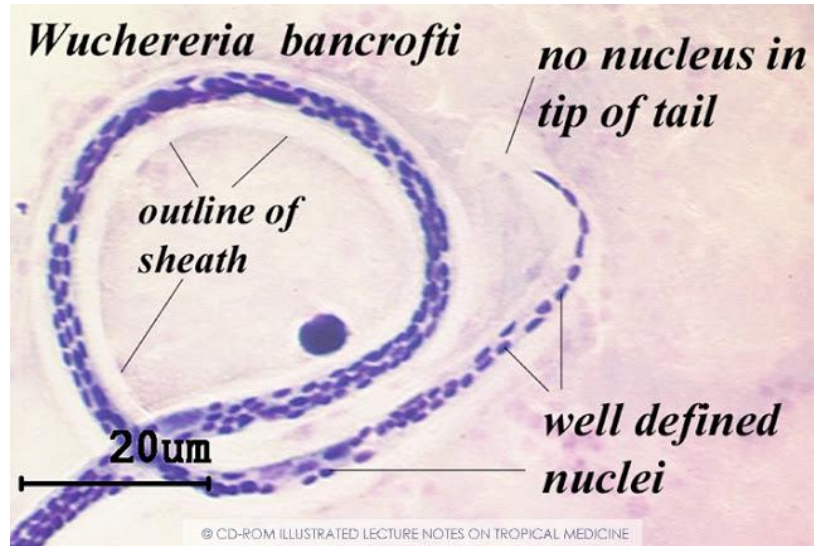

Figure of *Wuchereria bancrofti* microfilaria in a blood sample, from E. Van den Enden. 2004. Illustrated Lecture Notes on Tropical Medicine. Accessed 2018. The adults may appear as coiled bunches, and when they die in the lymph vessels, they can cause inflammation of lymph vessel and other damage to lymph vessels and valves.

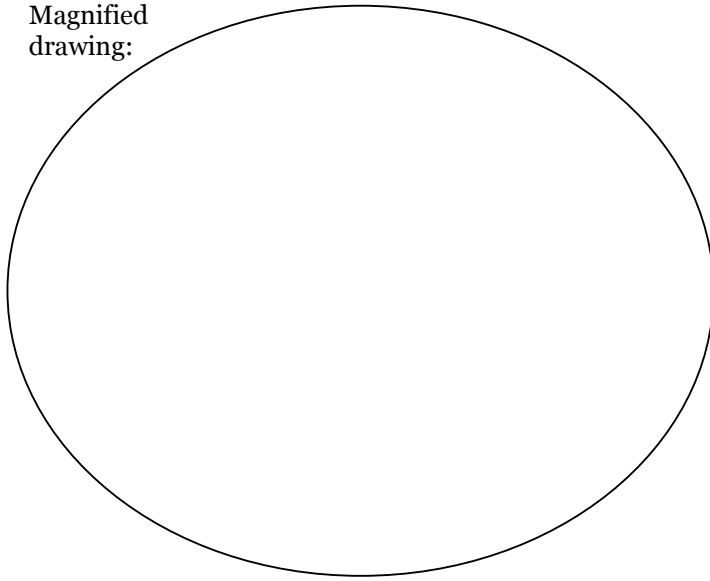

Image of person with lymphatic filariasis (sometimes called “elephantiasis”), due to a *Wuchereria* infection. From A. Cashin-Garbutt. 2013. Human filariasis research: an interview with Professor Mark Taylor, Liverpool School of Tropical Medicine. News Medical Life Sciences. Accessed 2018.

Toxocara canis (TALKS-oh-CARE-uh CANE-iss). Observe the adults, and notice their size and shape.

Life-size drawing:

Magnified drawing:



Roundworm (*Toxocara canis*)

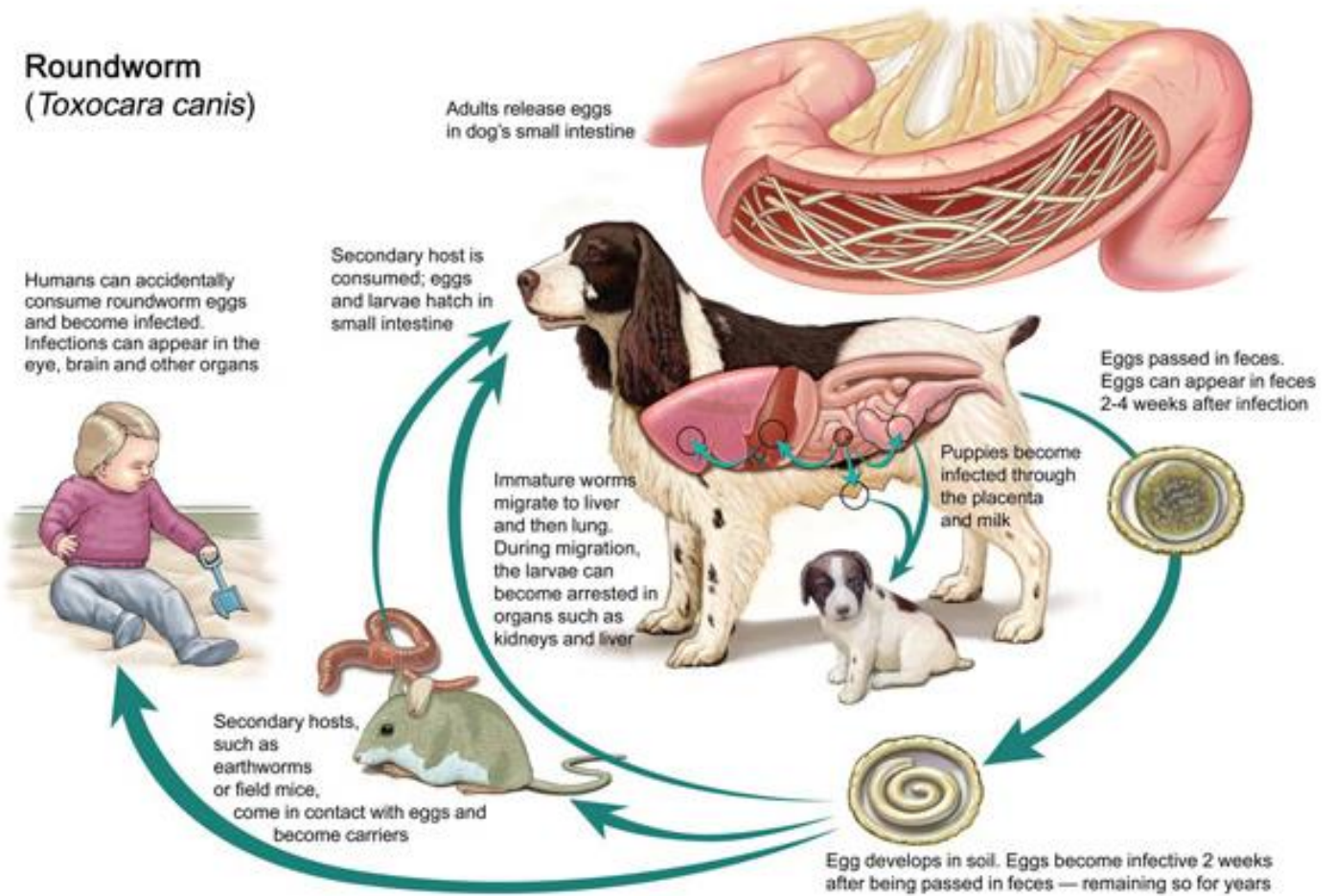
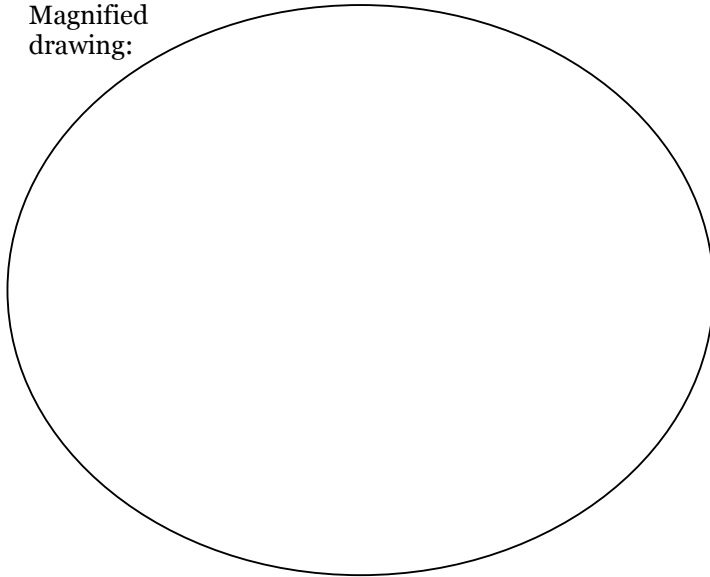

Figure of *Toxocara canis* life cycle from W. Winslet. Dogscatspets.org. Accessed 2018.

Pediculus humanus ssp. (peh-DIC-you-luss hew-MAN-us). Observe the adult. Notice and label the body shape, number of legs, leg features, and mouthparts.

Life-size drawing:

Magnified
drawing:



Flea Observe the adult. Notice and label the body shape, number of legs, and mouthparts.

Life-size drawing:

Magnified
drawing:

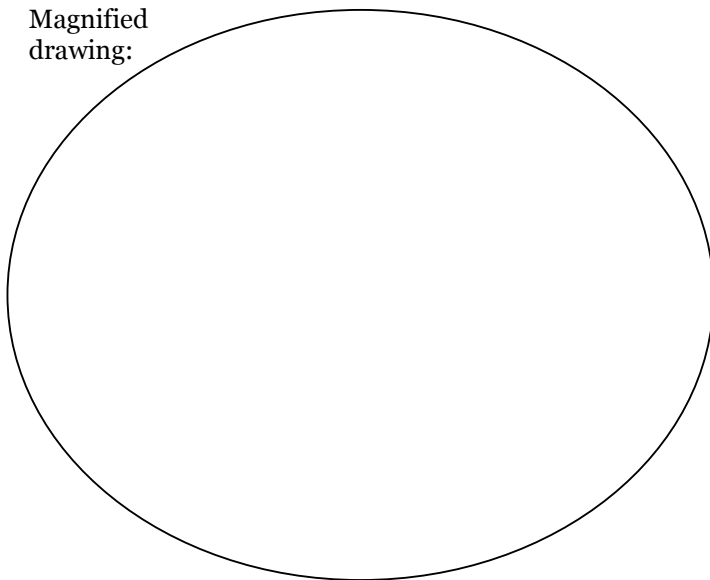

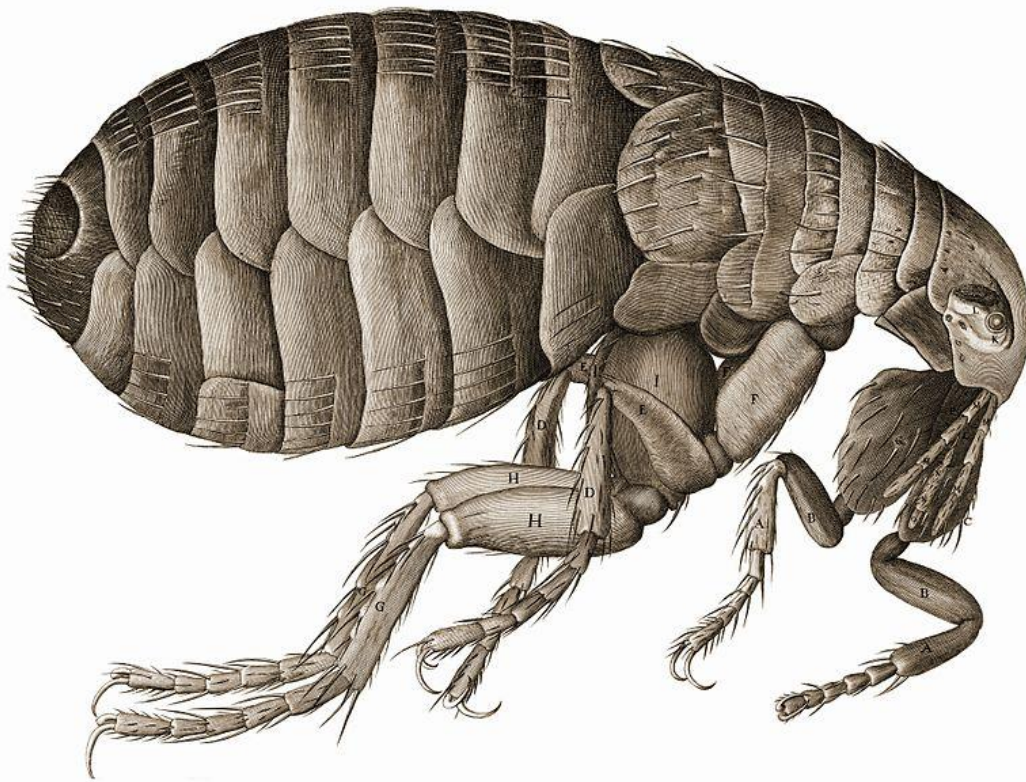

Robert Hooke drew a flea, too! Drawing of flea from Robert Hooke's *Micrographia*, 1665.

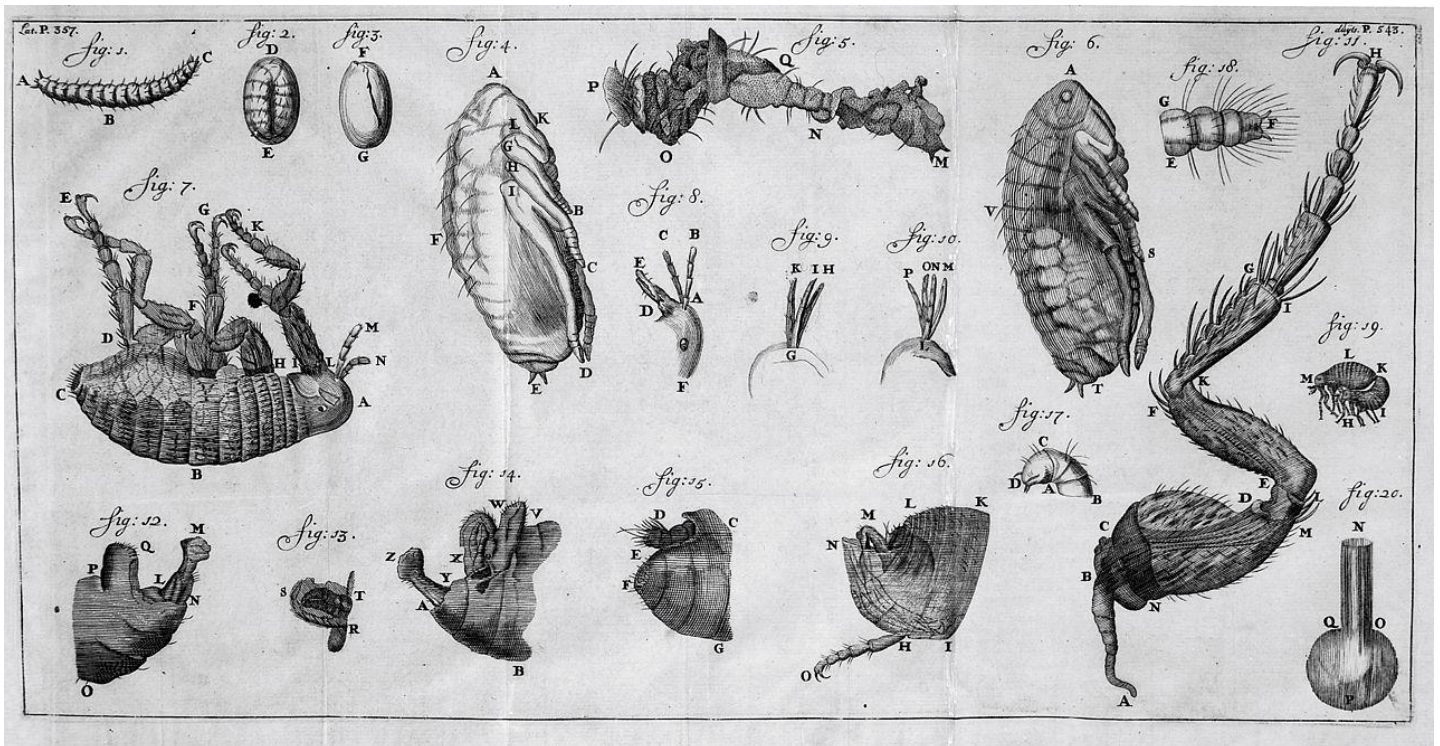

Even Antonie van Leeuwenhoek drew a flea! Development of the flea from egg to adult. From Antonie van Leeuwenhoek, c. 1680. Image from Wellcome Collection, London.

Tick Observe the adult. Notice and label the body shape, number of legs, and mouthparts.

Life-size drawing:

Magnified
drawing:

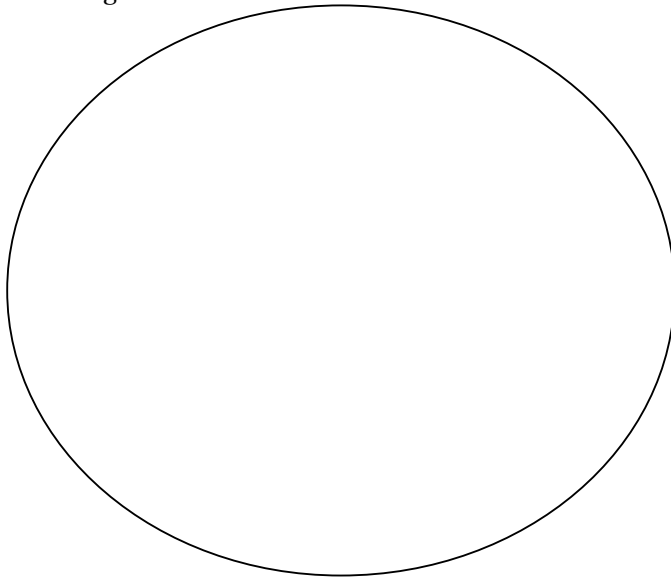

Mosquito Observe the adult. Notice and label the body shape, number of legs, and mouthparts.

Life-size drawing:

Magnified
drawing:

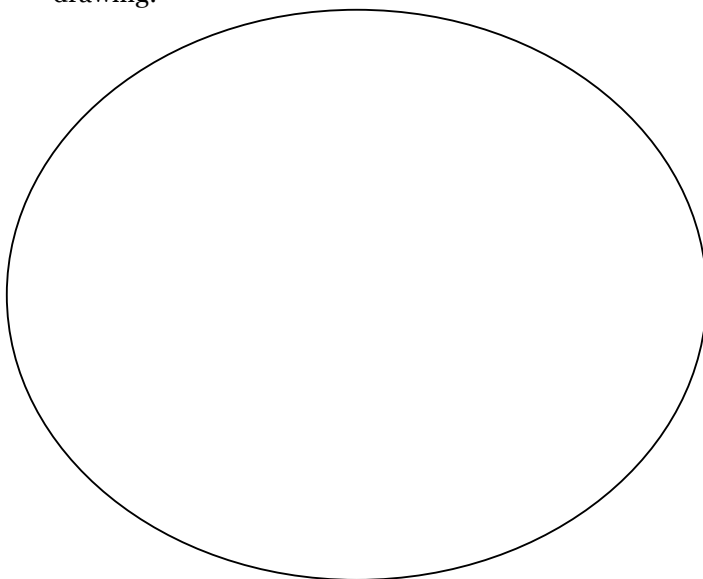







 Conenose Bugs <i>Transmit: Chagas' disease</i>	 Fleas <i>Transmit: plague, endemic typhus, dog tapeworm</i>	 Lice <i>Transmit: relapsing fever, epidemic typhus fever, trench fever</i>
 Hard Ticks <i>Transmit: Rocky Mountain spotted fever, "Q" fever, tularemia, Colorado tick fever</i> Cause: tick paralysis	 Soft Ticks <i>Transmit: relapsing fever</i> Cause: tick paralysis	 Mites <i>Transmit: tsutsugamushi (scrub typhus)</i> Cause: dermatitis
 Nonbiting Flies <i>Transmit: yaws, typhoid fever, dysenteries, cholera, conjunctivitis</i> Cause: myiasis	 Biting Flies <i>Transmit: tularemia, sandfly fever, onchocerciasis, African sleeping sickness, kala-azar, bartonellosis</i>	 Mosquitoes <i>Transmit: malaria, yellow fever, dengue, elephantiasis, encephalitis</i>

Table of selected arthropod vectors from C. Church. Parasitology, Biology 3270. Metropolitan State University of Denver. Accessed 2018.

Review Questions

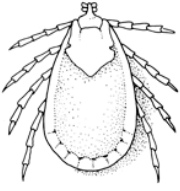
Organism	Approximate size	Disease(s) spread by organism
Louse		
Flea		
Tick		
Mosquito		Name three:

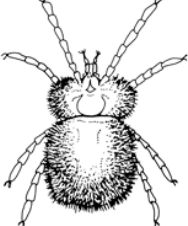
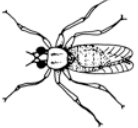
Species name	Common name (if any)	Roundworm, tapeworm, or fluke?	How transmitted	Part of body affected	Approximate size
<i>Taenia saginata</i>					
<i>Clonorchis sinensis</i>					
<i>Fasciola hepatica</i>					
<i>Schistosoma haematobium</i>					
<i>Ascaris lumbricoides</i>					
<i>Necator americanus</i>					
<i>Enterobius vermicularis</i>					
<i>Trichinella spiralis</i>					
<i>Wuchereria bancrofti</i>					
<i>Toxocara canis</i>					

Name the type of organism in each image. (Tick, louse, mosquito, or flea).

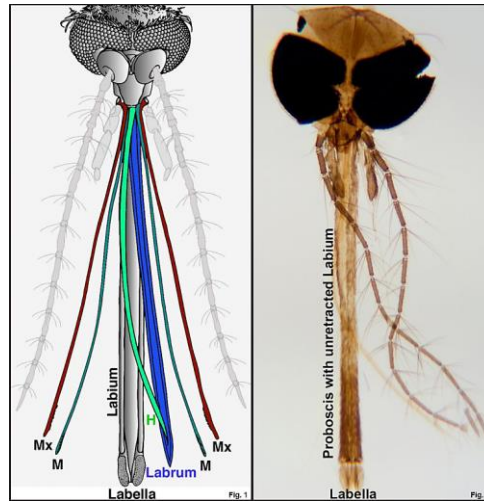
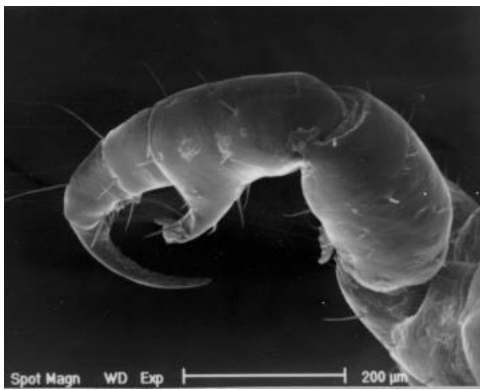

Figure sources:

- The National Pediculosis Association, Inc. headlice.org. Accessed 2018.
- S. Koch. University of Wisconsin-La Crosse. Accessed 2018.
- O. Aloni. 2018. theora.com. Accessed 2018.
- M. Oeggerli. *Micronaut: The art of microscopy*. Accessed 2018.
- Eye of Science / SPL / Barcroft Media. Accessed 2018.
- Choo, Buss, Tan and Leal. 2015. Creative Commons Attribution License (CC BY). *Front Physiol.* 2015; 6: 306. Published online 2015 Oct 29. doi: 10.3389/fphys.2015.00306
- Bugwoodwiki. Center for Invasive Species and Ecosystem Health at the University of Georgia. Accessed 2018.
- Tick. John Tann. 2011. Flickr.com. Accessed 2019.

Name _____

Date _____

Section # _____

Part 5: Cultivation and Identification of Bacteria

Exercise 9: Pure Culture Techniques

Objectives:

- Isolate bacteria by using streak plate and pour plate techniques.
- Prepare and maintain a pure culture.
- Complete a “pure culture challenge” by isolating three different species of bacteria from a mixed culture.

Introduction

Isolating single colonies

In the world outside the laboratory, bacteria grow in communities made of many bacterial species. If you need to identify the types of bacteria present in environmental or medical samples, you must have a way to separate out the different types and produce pure cultures. A pure culture contains a single bacterial species, whereas a mixed culture may contain many different types of bacteria. The methods described below are used to separate individual bacterial cells, and leave enough space between the cells so the cells can develop into isolated colonies.

The **streak plate method** is the most common isolation method. It involves using a loop to drag a sample of bacteria across the solid medium of a Petri plate. As the sample is dragged further and further, the cells become more and more spread out.

The **spread plate method** involves using a flat spreading rod (often made of bent glass) to smear a diluted sample across a plate.

The **pour plate method** mixes a diluted sample with melted agar. The mixture is poured into an empty dish, and the cells are dispersed in the medium.

Koch's Postulates

Koch's postulates are discussed here because they require the isolation of a single bacterial species. The postulates are a set of rules. The rules help to determine whether a particular pathogen causes a particular disease.

Koch's Postulates:

① The microorganism must be found in abundance in all organisms suffering from the disease, but should not be found in healthy organisms.

② The microorganism must be isolated from a diseased organism and grown in pure culture.

③ The cultured microorganism should cause disease when introduced into a healthy organism.

④ The microorganism must be reisolated from the inoculated, diseased experimental host and identified as being identical to the original specific causative agent.

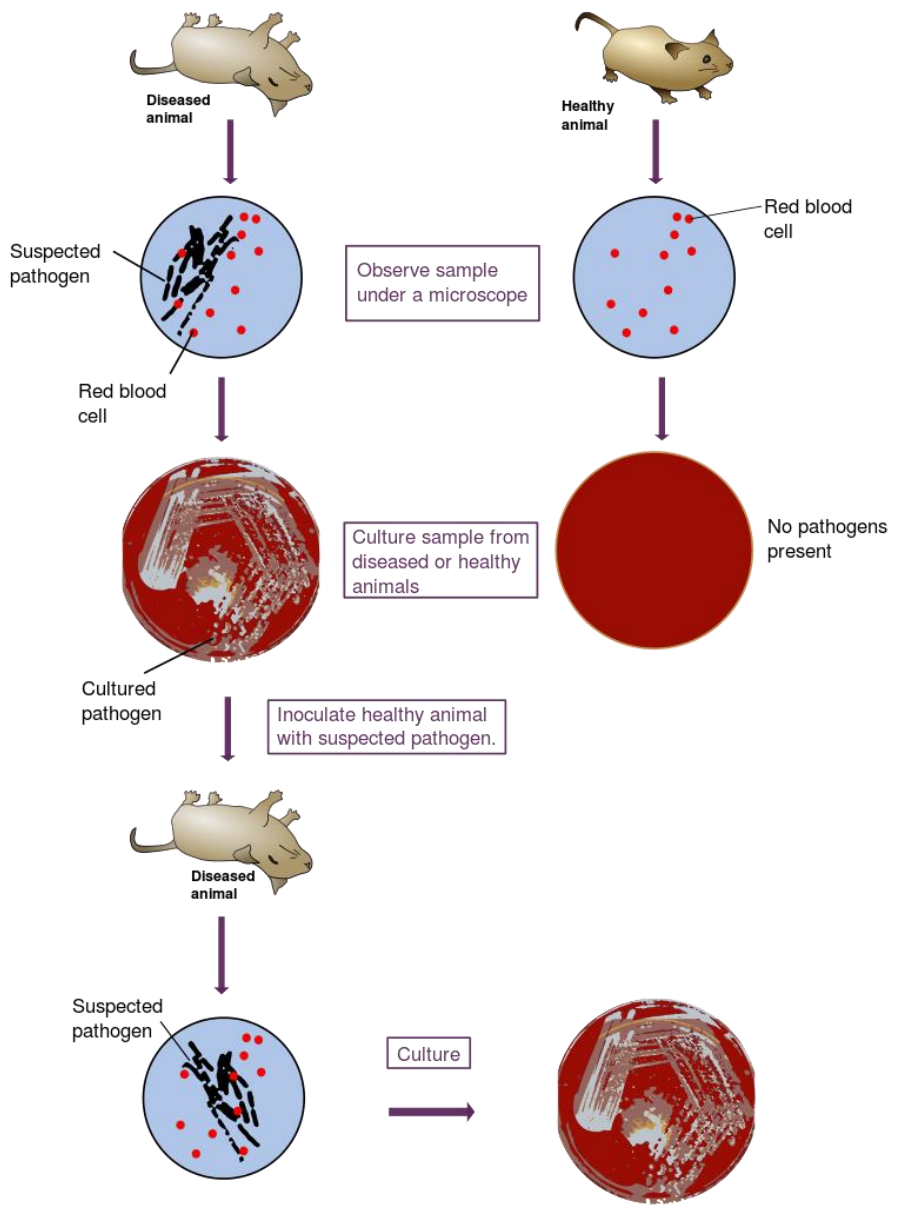

Diagram of Koch's postulates from Wikimedia Commons. Accessed 2018.

For the pure culture challenge, you will be working with a mixed culture of three bacterial species. These species are *Kocuria rhizophila*, *Serratia marcescens*¹, and one unknown bacterium that is able to cause urinary tract infections (UTIs). This mystery microbe will be indicated with a #1, 2, or 3.

Kocuria rhizophila colonies are what color? _____

Serratia marcescens colonies are what color? _____

Unknown UTI-causing organism colonies are what color? _____

¹ "co-CUR-ee-uh" and "sir-A-shuh"

Materials

- Tube of sterile water
- 4 melted agar deeps
- 4 petri dishes
- One mixed culture for your table
- For second meeting: 3 slants of T-soy agar

Instructions

1. Roll the mixed culture between your hands, to evenly distribute cells in the broth.
2. Dilute the mixed culture by moving one loop to 9 mL sterile water. Mix the new tube by rolling it between your hands.

Use this “diluted mixed culture” for all future inoculations.

Streak plate technique:

The main idea is to introduce a tiny amount of mixed sample, and then to spread the sample out with the loop.

3. Pour two plates, using melted agar deeps. Allow the plates to cool. Label the plates.
4. Introduce a loop of diluted mixed culture to one of the plates.



Figure of partially-opened plate from Carlson Stock Art. ©DaveCarlson/CarlsonStockArt.com. Accessed 2018.

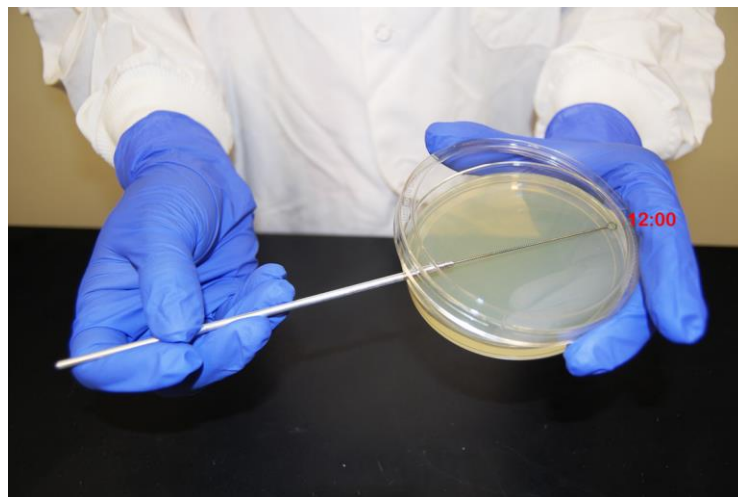

Image of partially-open plate from G. E. Kaiser. 2017. The Community College of Baltimore County. Accessed 2018.

- Use the loop to drag the sample across the plate in the pattern shown. Be sure to sterilize and cool your loop before moving to the next section of the plate.

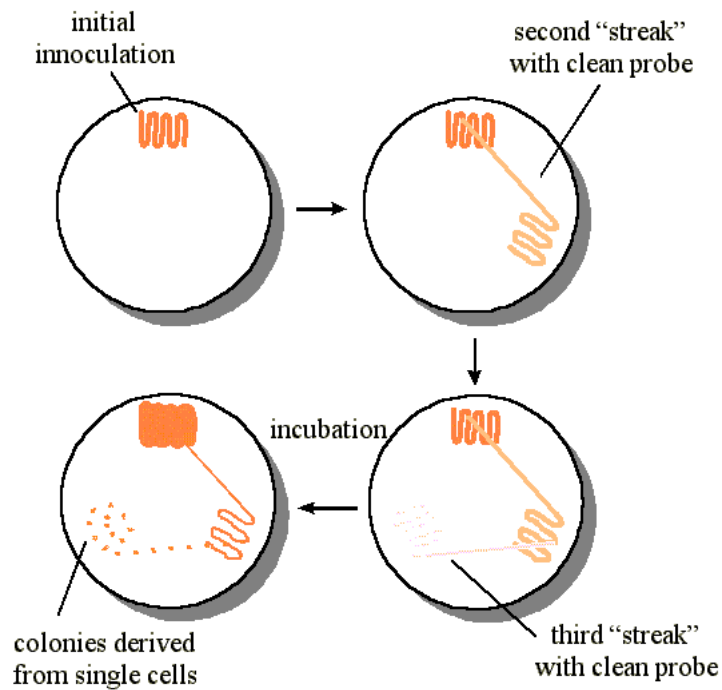

Figure of streak plate technique from M. Blaber. 1998. BCH5425 Molecular Biology and Biotechnology. Accessed 2018.

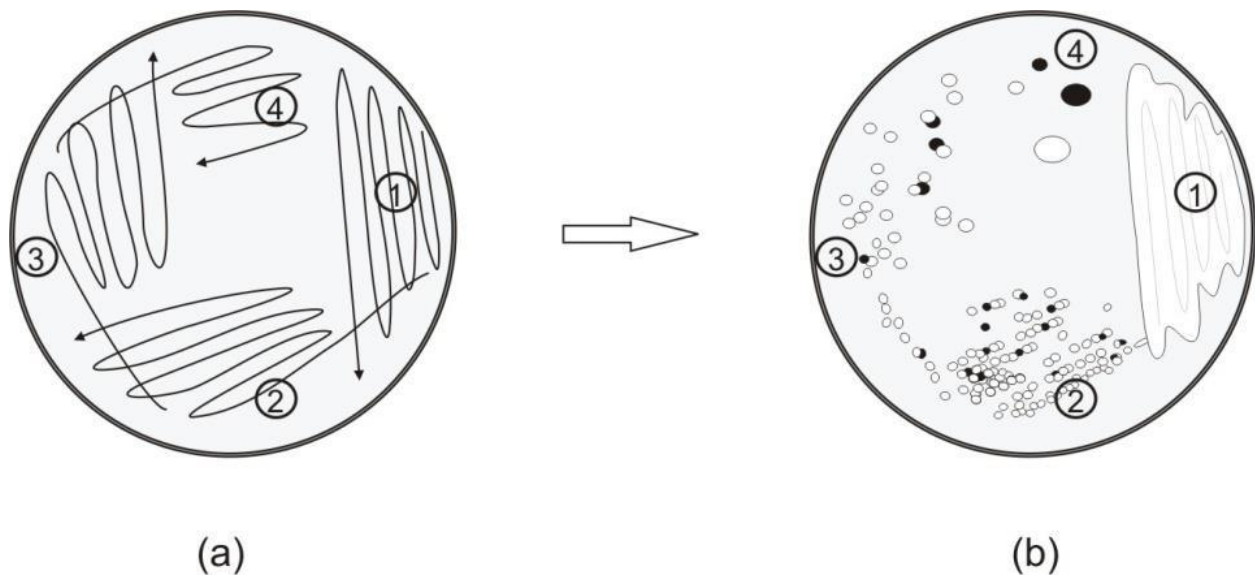

Figure of streak plate pattern, showing the original streak pattern (a), and the resulting growth (b). From K. Kerney. 2014. Florida Institute of Technology. Accessed 2018.

- Perform the streak pattern again on the second plate.

Pour plate technique:

This method uses the movement of the flowing agar to spread the organisms across the plate.

7. Take one melted deep from the water bath, and add one loop of your diluted mixed culture.
8. Mix the tube by rolling it between your hands.
9. Pour the plate.
10. Repeat for the second pour plate.

11. Incubate your plates as follows: Incubate one streak plate and one pour plate at room temperature. Incubate one streak plate and one pour plate at 37°C.

Results

Streak plates: Sketch your results below. Include colony colors.

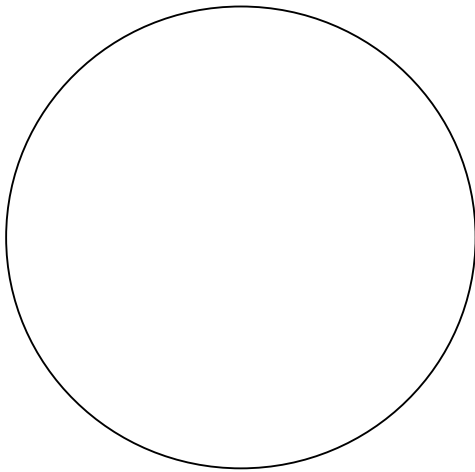

Room temperature

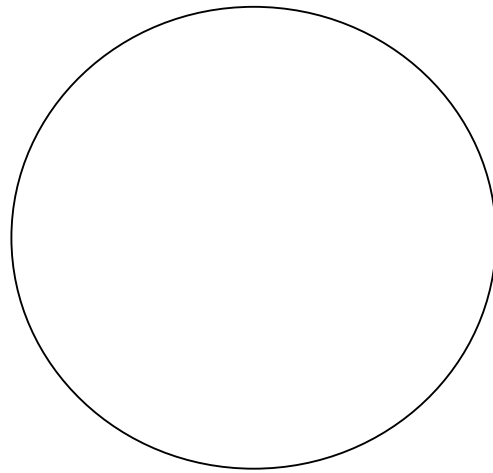

Incubated at 37°C

Pour plates: Sketch your results below. Include colony colors.

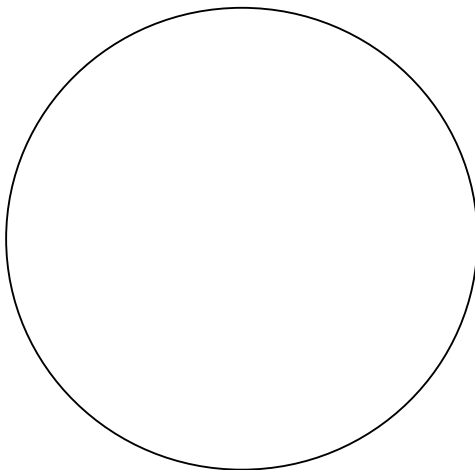

Room temperature

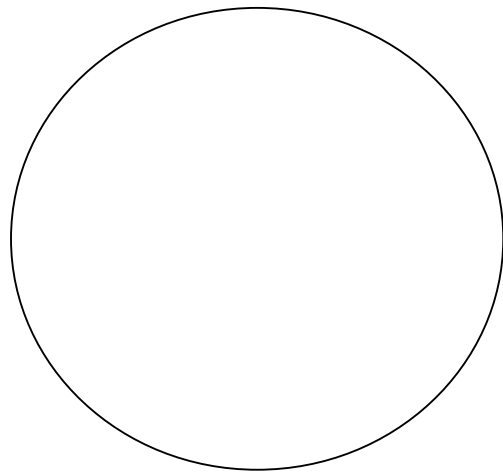

Incubated at 37°C

Next lab meeting: It's time to go fishing for bacteria!

Objective Make three agar slants, each with only a single bacterial species growing inside.

Instructions

1. Examine all of your plates to find isolated colonies.



Figure of single, isolated colony from G. E. Kaiser. 2017. The Community College of Baltimore County. Accessed 2018.

2. Use the straight needle to touch the surface of a selected colony, and streak this organism across a slant.
3. Incubate your *Kocuria* slant at 37°C. Incubate the others at room temperature.
4. In the next lab meeting, show your isolated slants to your instructor to collect your pure culture challenge points.
5. Save the UTI-causing organism for later identification.

Results Observe the growth on slants after incubation. Include colony colors.

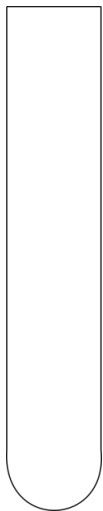

Kocuria rhizophila



Serratia marcescens



UTI specimen # _____

Review questions

1. Which of your slants appear to be pure cultures?
2. In your streak plate technique, why do you sterilize the loop after placing the original sample on the agar?
3. What is a pure culture?
4. What is a mixed culture?
5. Why is it important to be able to make pure cultures?
6. People have experimented with various media to make solid growth environments for growing separate bacterial colonies. Starch and gelatin melt at about body temperature, and are often digested by bacteria. Agar is different.
 - (a) At what temperature does agar solidify?
 - (b) At what temperature does agar melt?
 - (c) Some experiments require pouring of melted media over living cells, without killing the cells. At what range of temperatures could you have liquid agar?
 - (d) At what range of temperatures would agar remain solid?

7. Why do we incubate petri dishes upside down?

8. What does it mean for a colony to be “isolated” on a plate?

9. How might you determine whether a culture is pure?

10. On the pour plates, how do colonies on the surface differ in appearance from colonies buried in the agar? Why do you think this might be happening?

11. How might you determine whether a colony on a streak plate is a contaminant?

12. What do you think would happen if these plates were incubated for another week?

What if the plates were incubated for another month?

13. Regarding your streak plate technique, what is an area for improvement?

14. What is a disadvantage of the streak plate technique?

15. What is a disadvantage of the pour plate technique?

16. Why are Koch's postulates valuable?

17. How could you apply Koch's postulates to determine the cause of a disease that kills people?

18. How might you apply Koch's postulates to a pathogen that will not grow on culture media?

Name _____

Date _____

Section # _____

Exercise 10: Isolation of Pathogens

Objectives

Learn how to obtain clinical specimens, become familiar with culture media used to isolate pathogens, and make representative cultures.

Introduction

Growth media can be categorized based on their chemical constituents, or the purpose for which they are used.

- Complex growth media contain ingredients whose exact chemical composition is unknown (e.g. blood, yeast extract, etc.).
- Synthetic (also called chemically defined) growth media are formulated to an exactly defined chemical composition.
- A general purpose growth medium (e.g. tryptic soy agar (TSA) or Luria broth (LB)) is used to grow a wide variety of non-fastidious bacteria. This type of medium is often a complex growth medium.
- A selective growth medium contains chemicals that allow some types of bacteria to grow, while inhibiting the growth of other types. An example of a purely selective growth medium is PEA, phenylethyl alcohol agar, which allows Gram-positive bacteria to grow while inhibiting the growth of Gram-negative bacteria.
- A differential growth medium is formulated such that different types of bacteria will grow with different characteristics (e.g. colony color). An example of a differential growth medium is blood agar, which differentiates among bacteria based on their ability to break down red blood cells and hemoglobin. Blood agar is also a complex growth medium because it contains blood.

A growth medium can be both selective and differential. For example, EMB (eosin methylene blue agar) inhibits the growth of Gram-positive bacteria. Gram-negative bacteria that grow on this medium are differentiated based on their ability to ferment the sugars lactose and sucrose.

Medium	Classification	Contents	Organisms isolated
Blood agar	Enriched, differential	5-6% sheep blood	Most pathogens grow well; differential for hemolysis
Mannitol salt agar (MSA)	Selective, differential	7.5% NaCl, mannitol, phenol red	<i>Staphylococcus</i> spp.
Chocolate agar	Enriched	Cooked hemoglobin	Many fastidious pathogens grow well
Modified Thayer-Martin agar (MTM)	Selective, enriched	Cooked hemoglobin, antibiotics	<i>Neisseria</i> spp.
MacConkey agar	Selective, differential	Lactose, bile salts, neutral red, crystal violet	Gram-negative enteric bacilli
Eosin methylene blue agar (EMB)	Selective, differential	Lactose, eosin, methylene blue	Gram-negative enteric bacilli

Mannitol-salt agar (MSA): *Differential and selective growth medium.* This medium contains 7.5% NaCl, the carbohydrate mannitol and the pH indicator phenol red (yellow at pH <6.8; red at pH 7.4 – 8.4; pink at pH >8.4). It is selective for staphylococci due to the high concentration of NaCl, and differentiates based on the ability to ferment mannitol. Staphylococci that ferment mannitol produce acidic byproducts that cause the phenol red to turn yellow. This produces a yellow halo in the medium around the bacterial growth.

Blood Agar: *Enriched and differential growth medium.* The blood acts as an enrichment ingredient that enables fastidious organisms to grow, such as *Streptococcus* spp. The blood also enables us to distinguish among *Streptococcus* spp. based on how they interact with the blood cells. For example, if the bacteria do not break down the blood cells at all, there will be no change in the appearance of the medium around the colony. This lack of blood cell lysis is called “ γ -hemolysis.” If the bacteria partially break down the blood, and convert the hemoglobin to greenish methemoglobin, this is called “ α -hemolysis.” Finally, if the bacteria completely lyse the blood cells and take up the hemoglobin, the medium will look clear around the colony. This is called “ β -hemolysis.”

MacConkey agar: *Selective and differential growth medium.* Crystal violet acts as an inhibitor of gram-positive organisms, so this medium is good at isolating gram-negative organisms. The lactose and neutral red enable us to determine whether the organism makes acid from fermenting the lactose. Bacteria that can do this

lactose fermentation often come from the intestines, and are called “enteric” organisms. The bile salts may also precipitate out of the medium, depending on the amount of acid produced. *Escherichia coli* produces red colonies that are often surrounded by a fuzzy-looking halo of precipitated bile. *Enterobacter aerogenes* forms pink or red colonies that are glistening and mucoid. Organisms like *Salmonella* and *Proteus* do not ferment lactose, so produce translucent or colorless colonies.

Eosin-methylene blue agar (EMB): *Differential and selective growth medium.* This medium contains peptone, lactose, and sucrose, and the dyes eosin and methylene blue. Gram-positive organisms are inhibited by the dyes, so this medium is selective for gram-negative bacteria. The medium differentiates based on the ability to ferment lactose (and/or sucrose.) Organisms that cannot ferment either of the sugars produce colorless colonies. Organisms that ferment the sugars with some acid production produce pink or purple colonies; organisms that ferment the sugars and produce large amounts of acid form colonies with a green metallic sheen. This medium is commonly used to detect the presence of fecal coliforms (like *E. coli*)—bacteria that grow in the intestines of warm-blooded animals. Fecal coliforms produce large amounts of acid when fermenting lactose and/or sucrose; non-fecal coliforms will produce less acid and appear as pink or purple colonies. *E. coli* produces blue-black colonies with a metallic-green sheen. Other coliform bacteria produce pink, mucoid colonies. Colonies that do not ferment lactose or sucrose produce colorless colonies. Some of the color changes occur when colonies absorb the dyes.

Normal microbiota of the throat, skin, and intestinal tract

In order to identify a pathogen in a clinical specimen, it is important to separate out the patient's normal microbiota. It is valuable to be able to do this rapidly so that the patient can be treated accurately.

The normal microbiota are not randomly distributed, but live in particular environments generated by our bodies. Different regions of skin have different pH, oxygen concentrations, moisture levels, and secretions:

- The skin is likely to host staphylococci (mainly *Staphylococcus epidermidis*), streptococci (mainly alpha-hemolytic, gamma-hemolytic, or enterococci), diphtheroid bacilli, yeasts, and fungi.
- The mouth and teeth host anaerobic spirochetes and vibrios, fusiform bacteria (these cells taper toward each end), staphylococci, and anaerobic streptococci that produce levans and dextrans and help cause dental caries.

- The upper respiratory tract hosts staphylococci, streptococci (alpha-hemolytic, gamma-hemolytic, enterococci, and *Streptococcus pneumoniae*), diphtheroids, spirochetes, *Branhamella* spp., *Neisseria* spp., and *Haemophilus* spp.
- The small intestines host a small amount of Enterobacteriaceae bacteria. The large intestines and colon mainly host anaerobes such as *Bacteroides* spp., *Lactobacillus* spp., *Clostridium* spp., and *Streptococcus* spp. Other bacteria include a small percentage of aerobes (1-4%), and include gram-negative enteric bacilli (such as *E. coli* and *Enterobacter aerogenes*), enterococci, and a few species of *Proteus*, *Pseudomonas*, and *Candida*.

In this lab we will examine the organisms that inhabit several parts of your body.

Part A: Demonstration plates

Record your observations of the growth on all of these plates. Notice four things: the original medium color, whether or not there is growth, colony color, and the medium color around the colony.

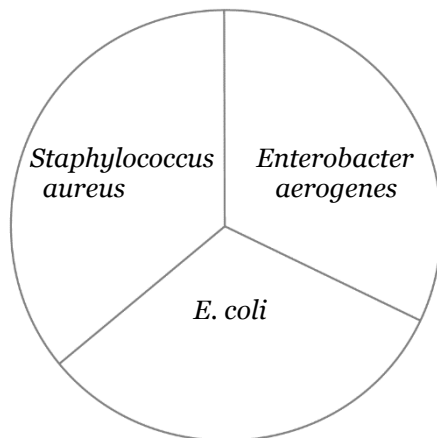
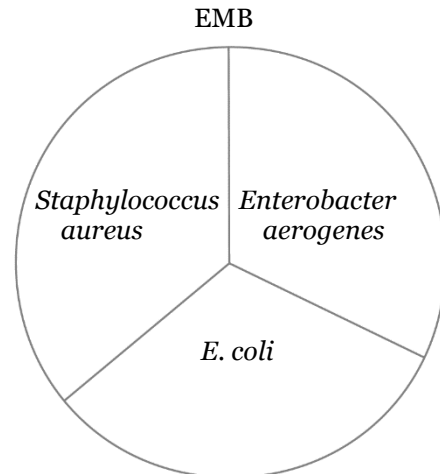
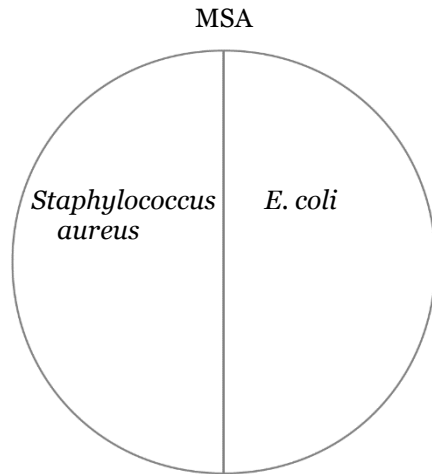

MacConkey

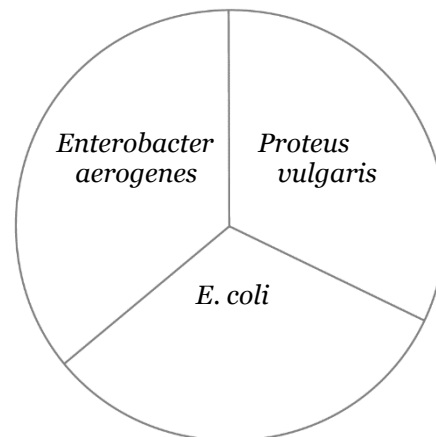

HardyCHROM™ UTI

Are these results what you expected? Why or why not?

Part B: Five media cultures

Materials, per student

- 1 T-soy agar plate
- 1 MSA plate
- 1 MacConkey plate
- 1 EMB agar plate
- 1 Blood agar plate
- Culture of UTI mystery microbe
- 3 sterile swabs

Instructions

1. Label your plates.
2. Divide the bottom of each plate into quadrants.
3. Label the quadrants for your throat, skin, nose, and UTI organism.

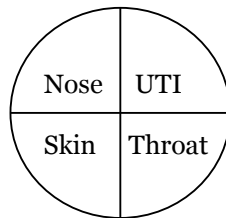

4. Take a throat culture from your lab partner by swabbing the back of their throat in the region of the uvula or tonsils. Try not to touch the cheeks or the tongue. Use this swab to inoculate the throat segments of all five plates. (Rotate the swab slightly between plates, to expose more of the sample.)
5. Moisten another swab with condensation from under the lid of a petri dish, or with sterile water. Rub the swab on your palm or any other skin. Use this swab to inoculate the skin segments of all five plates.
6. Moisten another swab with condensation from under the lid of a petri dish. Rub the swab inside your nose. Use this swab to inoculate the nose segments of all five plates.
7. Dispose of all swabs in the burn box.
8. Use a sterile loop to remove a small amount of your UTI microbe from your plate or slant. Use the loop to inoculate the UTI segments of all five plates.
9. Incubate the plates at 37°C.

Results

Use the T-soy plate as a reference to see what “heavy” growth might look like. For each plate segment, record the amount of growth (light, medium, heavy), colony appearance, and any changes in the agar.

T-soy

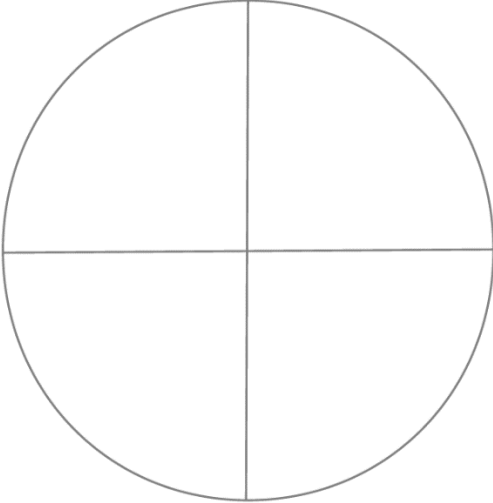

MSA

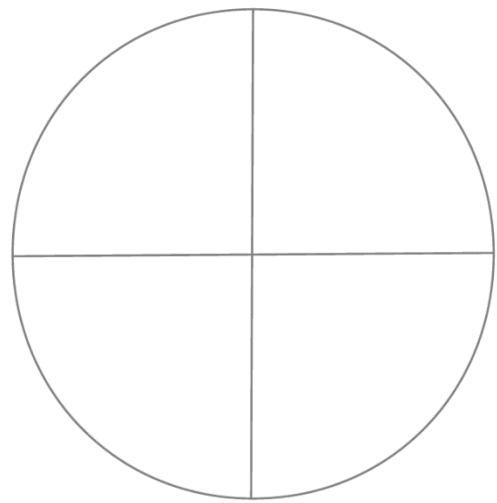

EMB

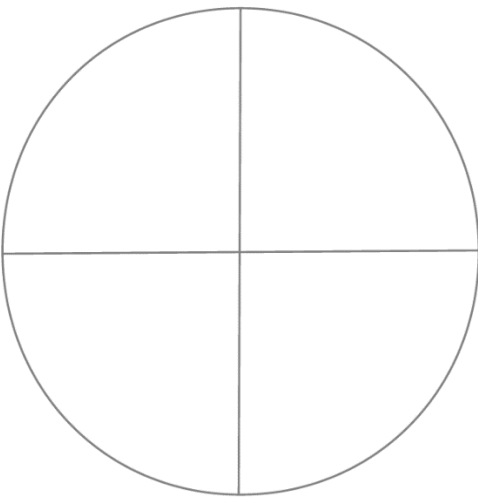

MacConkey

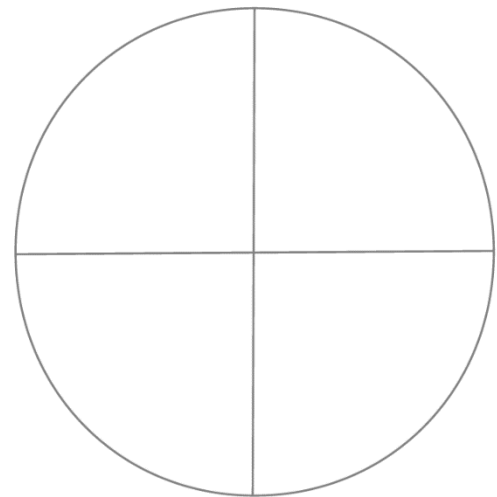

Blood agar

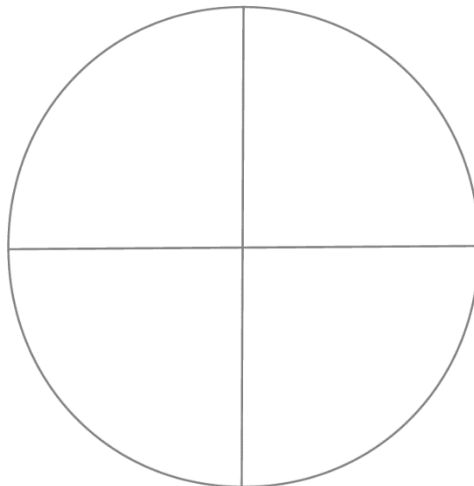

Part C: Slide of three UTI organisms

Instructions Observe the slide that contains a gram-stained mixture of UTI unknowns #1, 2, and 3.

Sketch your observations here:

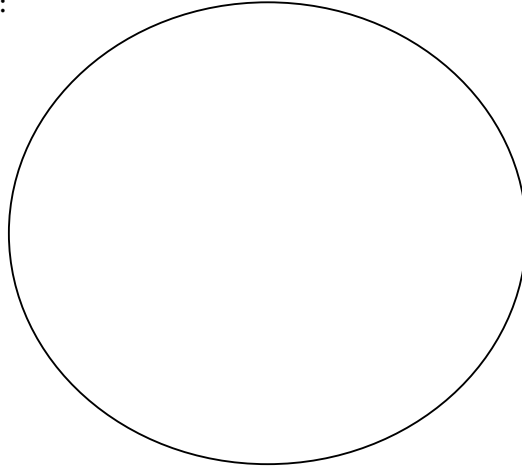

Describe the bacterial shapes:

What Gram reaction do they have?

Can you distinguish among these three species of bacteria?

Could you identify these three bacteria from just this slide?

Review questions

1. Why are some microorganisms called “normal microbiota”?
2. How does the host usually benefit from normal microbiota?

3. Define a differential medium. What is its purpose?

4. Define a selective medium. What is its purpose?

5. Why is MacConkey agar considered both selective and differential?

6. Why is EMB agar considered both selective and differential?

7. Why is blood agar useful as a medium?

8. Examining growth on EMB agar, how might you distinguish *Escherichia coli* from *Enterobacter aerogenes*?

9. Examining growth on MacConkey agar, how might you distinguish *Escherichia coli* from *Enterobacter aerogenes*?

10. Examining growth on EMB agar, how might you distinguish *Escherichia coli* from *Staphylococcus aureus*?

11. Complete this diagram with these three species: *Escherichia coli*, *Enterobacter aerogenes*, and *Staphylococcus aureus*.

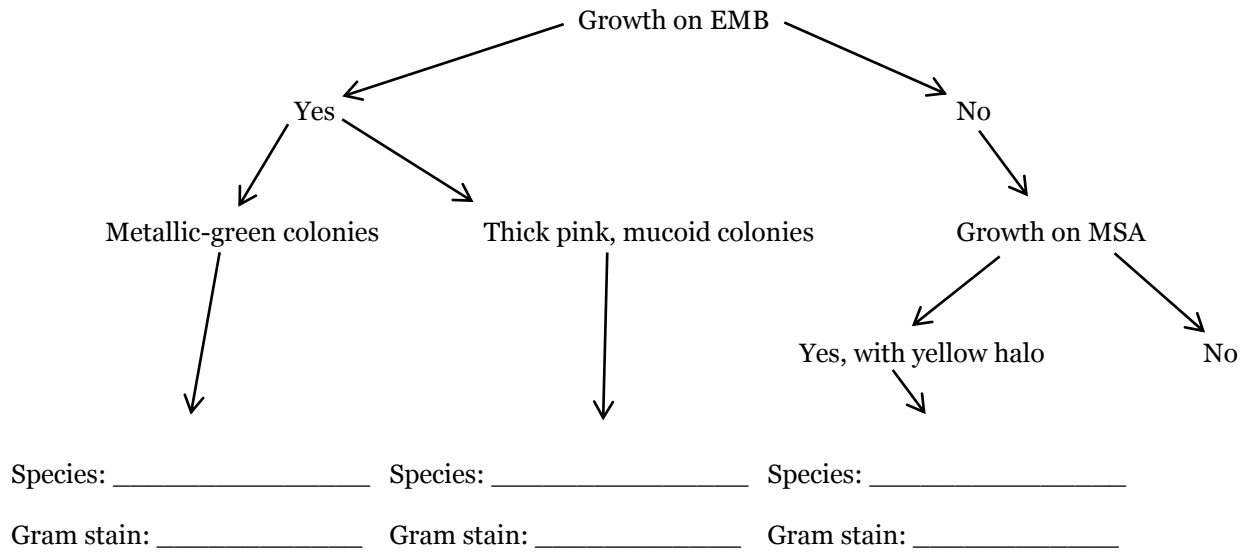

12. How can you distinguish among the three UTI-causing pathogens on the HardyCHROM UTI plate?

13. Why might people make a Gram stain directly from a clinical specimen?

14. Why is aseptic technique important in the laboratory?

15. Why is aseptic technique important in patient care?

16. A patient has an abscess on their neck. Describe the procedures you could use to determine what organism is causing the abscess.

Exercise 11: More Tests of an Unknown Bacterium

Objectives

Demonstrate biochemical characteristics, motility, and oxygen requirements of microorganisms.

Introduction

As you have observed, staining procedures can be used to distinguish among bacteria based on morphology, arrangement, cell wall structure, and other structures such as flagella, capsules, and spores. However, staining procedures are not sufficient to identify bacteria at the species level. For example, *E. coli*, *P. aeruginosa*, *P. vulgaris*, *E. aerogenes*, and many other bacteria are all gram-negative rods and are indistinguishable by Gram staining. All three of our UTI unknowns are also gram-negative. Therefore, additional methods are required to identify individual species.

Even though different bacterial species may appear identical under the microscope, they all have a different genetic makeup (different DNA), and therefore produce different types of enzymes that allow the bacteria to carry out a characteristic set of biochemical reactions. In other words, each bacterial species has a characteristic metabolism that can be used to distinguish them from other species, and therefore unknown bacteria are often identified based on both their appearance under the microscope as well as their metabolic properties.

For example, differences in metabolic properties were shown when we inoculated several species onto EMB agar. Each of these bacteria produced different-colored colonies on this medium, depending on their ability to ferment lactose. In addition to EMB, there are many other types of

differential media that can be used in the identification of bacteria.

When using differential media, remember that reactions in these media can vary based on the incubation time, the incubation temperature, the number of bacteria in the initial inoculum, and how the medium is inoculated, among other variables. For example, an inoculum containing large amounts of bacteria might give a strong positive reaction, while one containing a very small number of bacteria might only produce a weakly positive, or perhaps a negative reaction. Also, not all bacterial species will give definitive positive or negative results on these media. Since not all differential media will provide meaningful results for all bacterial species, it is important to choose the media carefully when identifying unknowns.

In many metabolic tests, end products are produced that change the pH of the medium. To measure this pH change, pH indicators (chemicals that change color depending on pH) are included in the medium. Some common pH indicators are phenol red, bromocresol purple, and bromothymol blue. Each pH indicator has a range of pH values over which it changes color (see below). For example, phenol red is red at pH values between 6.8 and 7.4. Below 6.8, it turns yellow, and above 7.4, it is pink or magenta.

Phenol red	pH < 6.8 = yellow	pH 6.8 – 7.4 = red	pH > 7.4 = pink / magenta
Bromothymol blue	pH < 6.0 = yellow	pH 6.0 – 7.5 = green	pH > 7.5 = blue

Materials, per student

- UTI unknown organism
- 1 motility deep
- 1 fluid thioglycolate medium (FTM)
- 1 phenol red *lactose* fermentation tube, with Durham tube inside
- 1 phenol red *glucose* fermentation tube, with Durham tube inside
- 1 urea broth
- 1 Simmons citrate agar slant

Motility determination

We have already seen the hanging drop technique for determining motility. This stab test is another technique. The motility deep is a semisolid agar with triphenyltetrazolium chloride (TTC). The initially-oxidized TTC is colorless. When bacteria absorb the TTC and reduce it, the TTC turns to an insoluble red pigment called formazan. The TTC helps indicate where bacterial growth has occurred. Only motile bacteria will grow away from the central stab line, often with fuzzy borders.

Materials, per student:

- UTI unknown organism
- 1 motility deep

Instructions:

1. Label the motility deep.
2. Pick up some of your UTI organism with a sterile inoculating needle.
3. Stab the needle two-thirds of the way to the bottom of the motility deep. Try not to disturb the medium.
4. Incubate.

Appearance of medium before inoculation:



After incubation, sketch your observations here:

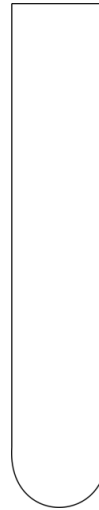

Questions:

1. Is your UTI organism motile?
2. If it were motile, does this method also reveal the arrangement of the flagella?

Oxygen requirements

This test uses fluid thioglycolate medium (FTM) to determine the oxygen requirements of microorganisms. The medium contains glucose, cysteine, agar, sodium thioglycolate, and resazurin. Sodium thioglycolate in the medium consumes oxygen and permits the growth of obligate anaerobes. This, combined with the diffusion of oxygen from the top of the broth, produces a range of oxygen concentrations in the medium along its depth. The oxygen concentration at a given level is indicated by the redox-sensitive dye resazurin that turns pink in the presence of oxygen. The small amount of agar thickens the medium and helps keep organisms from drifting freely throughout.

This medium allows the differentiation of obligate aerobes, obligate anaerobes, facultative anaerobes, microaerophiles, and aerotolerant organisms. For example, obligately anaerobic *Clostridium* species will be seen growing only in the bottom of the test tube.

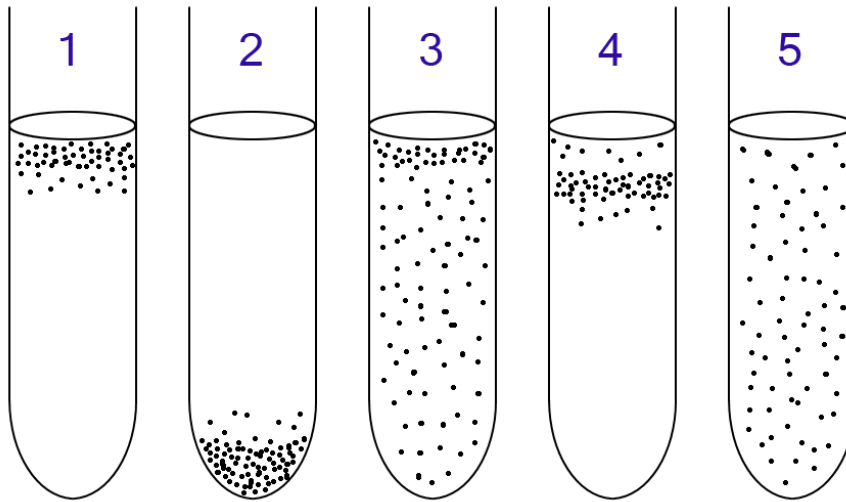

1: Obligate aerobes need oxygen because they cannot ferment or respire anaerobically. They grow at the top of the tube where the oxygen concentration is highest.

2: Obligate anaerobes are poisoned by oxygen, so they grow at the bottom of the tube where the oxygen concentration is lowest.

3: Facultative anaerobes can grow with or without oxygen because they can metabolize aerobically or anaerobically. They grow mostly at the top because aerobic respiration generates more ATP than either fermentation or anaerobic respiration.

4: Microaerophiles need oxygen because they cannot ferment or respire anaerobically. However, they are poisoned by high concentrations of oxygen. They grow in the upper part of the test tube, but not the very top.

5: Aerotolerant organisms do not require oxygen as they metabolize anaerobically. Unlike obligate anaerobes, though, they are not poisoned by oxygen. They can be found evenly spread throughout the test tube. (Figure and caption from Thioglycolate broth. Wikipedia. Accessed 2018.)

Materials, per student:

- UTI unknown organism
- 1 fluid thioglycolate medium (FTM)

Instructions:

1. Label the FTM tube.
2. Make a mark at the bottom of the pink region of the medium. This is where oxygen becomes less available.
3. Pick up some of your UTI organism with a sterile loop.
4. Gently dip the loop two-thirds of the way into the FTM tube. Try not to disturb the medium.
5. Leave the tube cap slightly loose, so that air may enter.
6. Incubate.

Appearance of medium before inoculation:



After incubation, sketch your observations here:

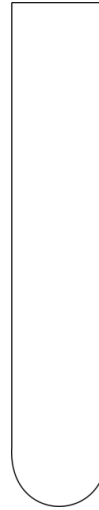

Questions:

1. What kind of oxygen requirement does your UTI organism have?
2. Define the following.
 - Obligate aerobe:
 - Facultative anaerobe:
 - Microaerophile:
 - Aerotolerant anaerobe:
 - Obligate anaerobe:

Carbohydrate Fermentation

Fermentation is a metabolic process that some bacteria use to break down glucose when oxygen gas is not available. Fermentation includes the reactions of glycolysis (where a single molecule of glucose is broken down into two molecules of pyruvate), as well as additional reactions that produce a variety of end products (acids, alcohols, gases). The end products are characteristic of individual bacterial species.

Although the main substrate molecule for fermentation is glucose, some bacteria use additional chemical reactions to convert other monosaccharides as well as disaccharides into glucose. Therefore bacteria can be differentiated both based on their ability to ferment various carbohydrates, as well as the end products that result from the fermentation process.

The medium used to test carbohydrate fermentation is a nutrient broth that contains a fermentable carbohydrate (usually a monosaccharide or a disaccharide), peptone (amino acids), as well as a pH indicator. The pH of the medium is adjusted to approximately 7.5, so it

appears orange/red when using phenol red. If the carbohydrate in the medium is fermented and acidic end products are formed, a color change to yellow will result.

Occasionally, bacteria will not ferment the carbohydrate, but instead will break down proteins producing ammonia (NH_3) in the growth medium. In this case, the medium will become more alkaline.

Some bacteria will produce gases when fermenting a carbohydrate. To detect these gases, a Durham tube is used. The Durham tube is a small inverted tube that is placed within the larger glass tube. If gases (typically CO_2) are produced during the fermentation process, a bubble will form at the top of the Durham tube. If you see a bubble in the Durham tube, the medium will also likely be acidic.

Carbohydrate fermentation media are often used to differentiate members of the family Enterobacteriaceae (e.g., *Escherichia coli*, *Enterobacter aerogenes*) from each other.

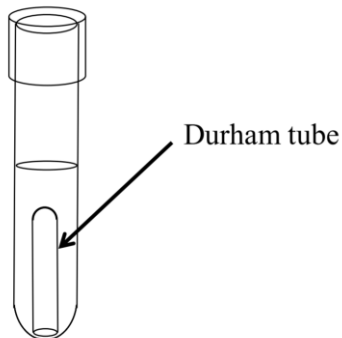

Materials, per student:

- UTI unknown organism
- 1 phenol red lactose fermentation tube, with Durham tube inside
- 1 phenol red glucose fermentation tube, with Durham tube inside

Urea Hydrolysis

Urea is a common waste product that results from the breakdown of proteins. Urea broths are used to test for the presence of a urease enzyme that is produced by some bacteria. Bacteria that produce ureases can break urea down into ammonia and carbon dioxide. The ammonia that results from the breakdown of urea causes the broth to become

more alkaline; this pH change is detected by the phenol red, which changes to a hot pink color. Organisms that do not break down urea may grow in the broth, but the broth will remain its original color, or will become more yellow (due to the production of acids). *Proteus* species are known to produce urease.

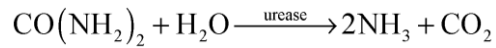

Materials, per student:

- UTI unknown organism
- 1 urea broth

Instructions:

1. Label the urea broth.
2. Use a loop to inoculate the tube with your UTI organism.
3. Incubate.

Appearance of medium before inoculation:

After incubation, sketch your observations here:



Questions:

1. Is the urea broth turbid after incubation?
2. Is your UTI organism positive or negative for urease production?

Citrate Utilization

Organisms that can survive using citrate as the sole source of carbon have a citrate permease enzyme that can transport citrate molecules into the cell. The citrate is then made into pyruvate, which can be converted into a variety of different products. Simmons citrate is a chemically defined medium that contains sodium citrate as the sole carbon

source, as well as the pH indicator bromothymol blue. Bacteria that can grow on this medium (i.e., that can survive on citrate as the sole source of carbon) produce alkaline byproducts that will change the medium from green (neutral pH) to blue (alkaline pH).

Materials, per student:

- UTI unknown organism
- 1 Simmons citrate agar slant

Instructions:

1. Label the Simmons citrate agar slant.
2. Use a needle to streak your UTI organism across the slant. (A loop introduces too heavy an inoculation.)
3. Incubate.

Appearance of medium before inoculation:



After incubation, sketch your observations here:

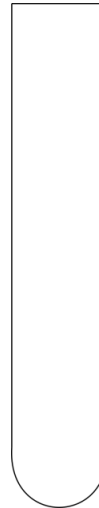

Questions:

Is your UTI organism positive or negative for urease production?

2. The organism ferments lactose and produces gases. What do you use to detect gas production?

What do you see that indicates that gases are produced?

3. In the urea test, what happens to the pH of the medium when an organism breaks down urea?

What molecule causes this pH change?

4. Fill in the following to summarize these metabolic tests.

Lactose Fermentation Test

Medium used:

Inoculation procedure: (stab, streak, or dip the loop?)

Appearance of positive result:

Appearance of negative result:

Biochemical reaction/ Enzyme involved in positive result:

What causes the change in the medium's appearance? (e.g. pH change, enzyme activity, etc.)

Urease Test

Medium used:

Inoculation procedure: (stab, streak, or dip the loop?)

Appearance of positive result:

Appearance of negative result:

Biochemical reaction/ Enzyme involved in positive result:

What causes the change in the medium's appearance? (e.g. pH change, enzyme activity, etc.)

Citrate Permease (Simmon's citrate test)

Medium used:

Inoculation procedure: (stab, streak, or dip the loop?)

Appearance of positive result:

Appearance of negative result:

Biochemical reaction/ Enzyme involved in positive result:

What causes the change in the medium's appearance? (e.g. pH change, enzyme activity, etc.)

Exercise 12: Rapid Bacterial Identification

Objectives

Understand the meaning of “enteric,” compare the media and conventional tube methods you've used, and learn to use the API 20E system.

Introduction

Bacteria are often identified by their morphology, special structures, and metabolic abilities. However, setting up individual tests as we have been doing is time-consuming, and it can be expensive to maintain stocks of all of these media types. As an alternative, some companies have developed kits that contain multiple types of media within a single system. These “rapid methods” still require 18 to 24 hours of incubation, but the results usually lead to reliable identification of a bacterial species.

The rapid test system we will use is called the API 20E system, developed by a company called bioMérieux. API stands for Analytical Profile Index, which is the name of the numbering system used to interpret results. The test strip includes 20 small wells containing dehydrated media, and the E stands for the bacterial family Enterobacteriaceae, which this system is meant to work within. (Note: The definition of coliforms is not completely specific to bacteria of fecal origin. In addition, the definition of total coliforms can vary by country and public health organizations.)

Once the test strip is inoculated with a bacterial suspension, the bacteria react with the various media types to produce color changes. While this test can take a day to complete, some hospitals have developed more advanced systems that can identify and determine antimicrobial susceptibility in as little as two hours.

The term “enteric” can be used in several different ways. Enteric bacteria are bacteria of the intestines, and the term may refer to gut flora, which are usually harmless, or refer to pathogenic bacteria that cause bacterial gastroenteritis, or refer to the family Enterobacteriaceae. This lab uses the term “enteric” to refer to members of the family Enterobacteriaceae. In any case, the enteric bacteria are responsible for many nosocomial, abdominal, urinary tract, and wound infections, as well as food poisoning. The family Enterobacteriaceae is part of the class Gammaproteobacteria within the phylum Proteobacteria. They are gram-negative facultative anaerobes, and do not form spores. Many are motile.

Figure of bacterial groups from C. P. Gerba. 2009. Environmental Microbiology, second edition. Ch. 23, p. 485-499. Accessed 2018.

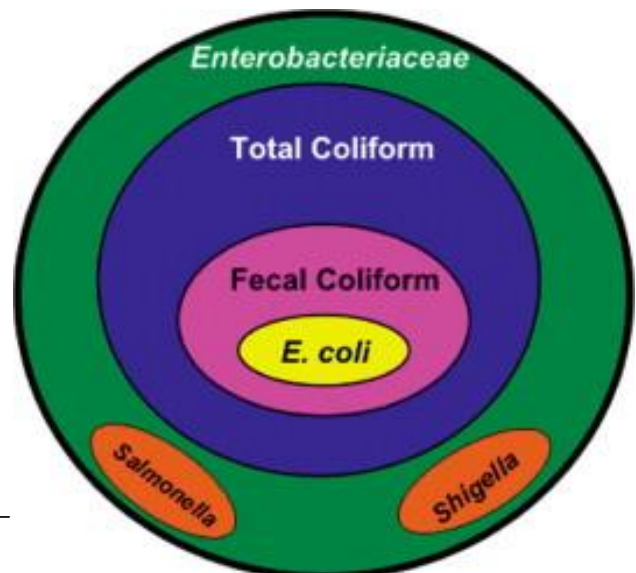

Materials, per table

- Broth culture of UTI unknown
- API 20E test strip
- Sterile mineral oil
- Deionized water
- 5 mL of 0.85% saline solution

Instructions

Set up test

1. Pipette two drops of UTI broth into the saline solution. Roll the tube between your hands.
2. Label the test strip tray with your team name and unknown number.
3. Fill the depressions in the emptied tray with deionized water, as though you are going to make tiny ice cubes. Dump out excess water. This will help maintain a humid environment.
4. Place the test strip back in the tray.
5. To prepare for inoculation, just notice the labels on the test strip. The underlined labels mean we will not fill those wells all the way. The boxed labels mean that those wells will have their cupule completely filled to allow more diffusion of oxygen. All other wells will eventually be filled as shown in the diagram.

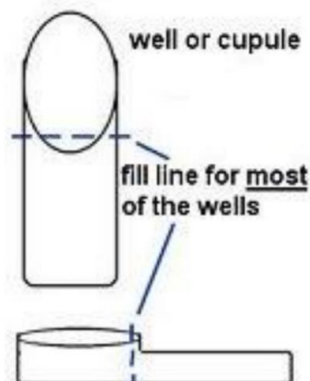

Figure from J. Reynolds. 2012. Biology 2421 Lab Procedures Manual. Richland College. Accessed 2018.

6. Fill a sterile pipette with the bacterial saline suspension.
7. Hold the strip at a slight angle up from the table top, and inoculate the bacterial suspension into each well with the sterile pipette. (Hint: Touch the end of the pipette to the side of the cupule, allowing capillary action to draw the fluid into the well as you slowly squeeze the bulb. This should eliminate any bubbles forming in the wells.)

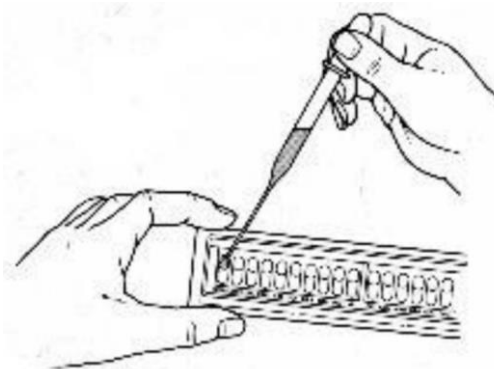

Figure from J. Reynolds. 2012. Biology 2421 Lab Procedures Manual. Richland College. Accessed 2018.

8. For the underfilled wells, use a pipette to add sterile mineral oil on top of the bacterial suspension in the wells, filling the cupule. This is meant to generate anaerobic conditions.
9. By now, all of the wells should have been inoculated.
10. Place the lid back on the incubation tray and incubate at 37°C for 18-24 hours. If the results are not read after 24 hours, the test strips should be moved to a refrigerator (2 – 8°C) until interpretation.

Interpret test strip

Materials, per table

- 10% ferric chloride
- Voges-Proskauer reagents A and B
- Kovac's reagent
- Access to online Analytical Profile Index

Instructions

1. After 18-24 hours of incubation, add one drop of 10% ferric chloride to the TDA well. If there is a positive reaction, the well will turn brownish-red immediately. A negative result is yellow.
2. Add one drop each of Voges-Proskauer reagents A and B to the VP well. Wait ten minutes to read this result. A positive reaction is dark pink or red.
3. Add one drop of Kovac's reagent to the IND well. A positive reaction generates a red ring within two minutes. (After two minutes, acids will react with the cupule to produce a brownish-red color, but this is not a positive result.)
4. Record results from all of the other wells. If a result is not obviously positive or negative, record this as both +/-.
5. Use the results to generate a profile number. Positive results get points, and negative results count 0.

Test	Substrate	Comments	Positive result	Negative result
ONPG	O-nitrophenyl- β -D-galactopyranoside	ONPG is hydrolyzed by the enzyme that hydrolyzes lactose, producing a yellow chemical.	Yellow	Colorless
ADH	Arginine	Arginine dihydrolase transforms arginine into ornithine, NH ₃ , and CO ₂	Red	Yellow
LDC	Lysine	Decarboxylation of lysine liberates cadaverine	Red	Yellow
ODC	Ornithine	Decarboxylation of ornithine produces putrescine	Red	Yellow
CIT	Citrate	Citric acid used as sole carbon source	Dark blue	Light green
H ₂ S	Sodium thiosulfate	Blackening indicates reduction of thiosulfate to H ₂ S	Black	Colorless, gray, or pale yellow
URE	Urea	Urea is hydrolyzed by urease into NH ₃ and CO ₂	Red or pink	Yellow
TDA	Tryptophan	Deamination of tryptophan produces indole and pyruvic acid	Brown	Yellow
IND	Tryptophan	Kovac's reagent helps detect indole	Red or pink ring	Yellow
VP	Sodium pyruvate	Addition of potassium hydroxide (KOH) and α -naphthol detects the presence of acetoin	Red	Colorless
GEL	Charcoal gelatin	Gelatin hydrolysis	Black pigment diffuses throughout	Black pigment is still in chunks
GLU	Glucose	Fermentation	Yellow or yellow-green	Blue or green
MAN	Mannose	Fermentation		
INO	Inositol	Fermentation		
SOR	Sorbitol	Fermentation		
RHA	Rhamnose	Fermentation		
SAC	Sucrose	Fermentation		
MEL	Melibiose	Fermentation		
AMY	Amygdalin	Fermentation		
ARA	Arabinose	Fermentation		

Table adapted from bioMerieux, Inc.

Indicate positive (+) and negative (-) results in the “results” line. Determine the profile number by adding the values above the positives. For example:

	ONPG	ADH	LDC	ODC	CIT	H ₂ S	URE	TDA	IND	VP	GEL	GLU
	1	2	4	1	2	4	1	2	4	1	2	4
Results	-	-	-	+	+	+	+	+	-	+	-	+
Profile #	0			7			3			5		

Enter your results:

	ONPG	ADH	LDC	ODC	CIT	H ₂ S	URE	TDA	IND	VP	GEL	GLU
	1	2	4	1	2	4	1	2	4	1	2	4
Results												
Profile #												

	MAN	INO	SOR	RHA	SAC	MEL	AMY	ARA	Oxidase	NO ₂	N ₂ gas
	1	2	4	1	2	4	1	2	4	X	X
Results									X	X	X
Profile #										X	

Final confirmation

1. Visit the API website at <https://apiweb.biomerieux.com>.
2. Gain access. Login: **cbriggs**
Password: **microbesrule**
3. Choose the API20E test. Examine the instructions and example color images of results if needed.
4. Enter your seven-digit profile number.
5. Read your report:
 - Significant taxa = the likely species name(s).
 - % ID = the probability of correct species identification.
 - T = the typicity index (or a measure of how typical that organism is, compared with other profiles within that species).
 - Tests against = the frequency that this species has the opposite result.
 - Next taxon = other possible species name(s).
6. Write the name of the most likely species: _____

Review questions

1. What is meant by the term “enteric pathogen”?
2. Is it usually possible to use just a stained slide to identify bacteria? Why or why not?
3. What is the purpose of the API 20E system?
4. What groups of professionals use this system?
5. Why might the API 20E system fail to identify some of the bacterial cultures we use?

Exercise 13: Summary of UTI Results

Objectives Use results of exercises 10-13 to identify your mystery microbe.

Introduction

We have used several methods to identify your UTI unknown. If you had a presumptive identification just based on the selective and differential media, congratulations. If your API 20E results gave an identification with a high degree of certainty, that is also good. We now have one additional opportunity to confirm results, using information from Bergey's Manual of Determinative Bacteriology.

UTI unknown #1: Gram-negative rods, motile, facultative anaerobe, citrate -, lactose +, urease -.

UTI unknown #2: Gram-negative rods, motile, facultative anaerobe, citrate +, lactose +, urease -.

UTI unknown #3: Gram-negative rods, motile, facultative anaerobe, citrate +/-, lactose -, urease +.

Review Questions

1. Check your results for accuracy, using your summary from the end of Lab 11. Do your results match the characteristics given above?
2. Compare your results to the following flow chart. Circle which characteristics applied to your organism, and circle the genus that matches best.

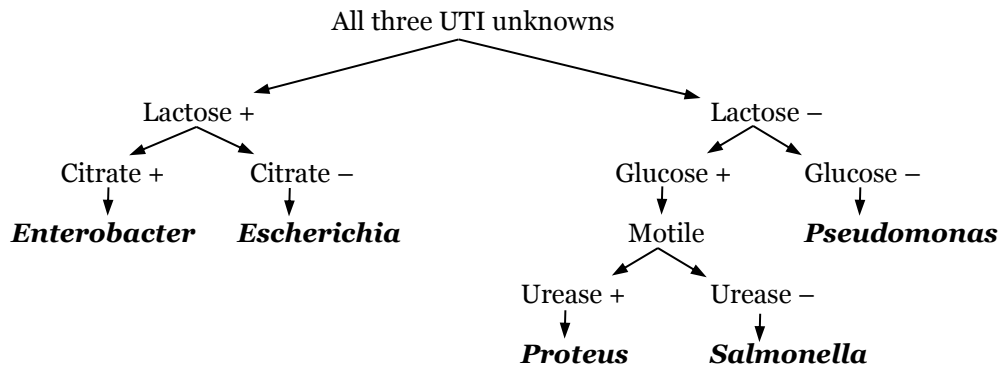

3. Did the flow chart results agree with your other identifications? Why do you say so?

Part 6: Control of Microbial Growth

Exercise 14: Susceptibility to Antibiotics, Dyes, and Metals

Objectives

Learn to perform antimicrobial susceptibility tests using paper discs. Test effects of dyes and metals.

Introduction

The use of antimicrobial agents to treat infections began in the early 1900s, when Paul Ehrlich developed Salvarsan to treat individuals infected with *Treponema pallidum*, the spirochete that causes syphilis. In 1928, Alexander Fleming later observed that the *Penicillium* mold growing on his agar plates could inhibit the growth of bacteria: years later penicillin was purified and used to treat many types of infections. Since this time, many other antimicrobial agents have been used to treat a wide variety of bacterial infections. Antibiotic producers include many types of fungi (*Penicillium*, *Cephalosporium*) and bacteria (*Bacillus*, *Streptomyces*). In addition, many antimicrobial agents currently used to treat

infections are either synthetic (made in a laboratory) or semi-synthetic (a modification of a naturally-produced antibiotic). Today there are over 100 different antimicrobials that are used to treat infectious diseases. These include broad-spectrum and narrow-spectrum antimicrobial drugs (see chart below). Narrow-spectrum drugs are more desirable to use whenever possible because they target the pathogen more specifically and do less damage to the normal microbiota; broad-spectrum drugs are used when the cause of the infection is unknown or when other antibiotics are not effective.

	Mycobacteria	Gram Negative	Gram Positive	Chlamydiae	Rickettsiae
Tetracyclines		←————→			
Streptomycin	←————→				
Penicillin		←————→			
Sulfonamides, Quinolones, Cephalosporins		←————→			
Vancomycin			←————→		
Polymyxin		←————→			
Isoniazid	←————→				

Table of activity spectra of the major classes of antibiotics, from Petersen, J. and S. McLaughlin. 2016. Laboratory Exercises in Microbiology: Discovering the Unseen World Through Hands-On Investigation. CUNY Academic Works. Accessed 2018.

It is important to remember that not all antibiotics are effective at killing all types of bacteria. Bacteria may have intrinsic resistance to a particular antibiotic. For example, gram-negative bacteria are intrinsically resistant to vancomycin because the drug cannot penetrate the outer membrane of the gram-negative cell wall. Also, the misuse and overuse of antibiotics has led to the evolution of resistance among bacteria by selecting for individual cells within a population that are not affected by the drug. This acquired resistance can occur in several ways, including through transformation, conjugation and mutation.

Antibiotic-resistant bacteria have become a major problem of growing concern in health care, as it is often difficult (or impossible) to treat bacterial infections caused by these microbes (for example, multidrug-resistant *Staphylococcus aureus*, or MRSA). Therefore clinical isolates are often tested for their antibiotic susceptibility in a laboratory setting so that health care providers can choose an appropriate drug to treat a particular infection.

The efficacy of a chemical at controlling bacterial growth can be tested in several ways. One way is to inoculate an agar plate with a lawn of bacteria and

add filter paper disks that have been moistened with the chemical being tested. This is known as the filter paper disk method, or agar disk diffusion assay. After incubation, plates are observed for the presence of a zone of inhibition (area around a disk where no microbial growth is detected). Generally speaking, the larger the zone, the more effective the chemical is against that particular microbe. However, other factors such as the solubility of the test agent and the molecular weight of the chemical molecules (which determines the diffusion rate of the chemical through the agar) can also affect results.

There are several ways to determine antibiotic susceptibility in a laboratory setting—one common test is called the Kirby-Bauer method. This method is similar to the filter paper disk method used to test disinfectants, except that it uses filter paper disks impregnated with a known concentration of an antimicrobial compound. When performing the Kirby-Bauer method, it is important to measure the size of the zones of inhibition and compare them to a set of standardized values established by the Clinical Laboratory Standards Institute (CLSI).



Figure of filter paper disk method experiment showing zones of inhibition, from Petersen, J. and S. McLaughlin. 2016. Laboratory Exercises in Microbiology: Discovering the Unseen World Through Hands-On Investigation. CUNY Academic Works. Accessed 2018.

Materials, per table

- Assigned culture: _____
- 6 T-soy agar plates
- Several sterile swabs
- Drug discs in dispensers
- Plain paper discs for dyes

Set-up Instructions

1. Label your plates #1 through 6.
2. Inoculate all six plates with your assigned organism. Start by dipping a sterile swab into the culture of your assigned organism. Remove excess liquid by pressing and rotating the swab firmly against the side of the tube above the level of the liquid.

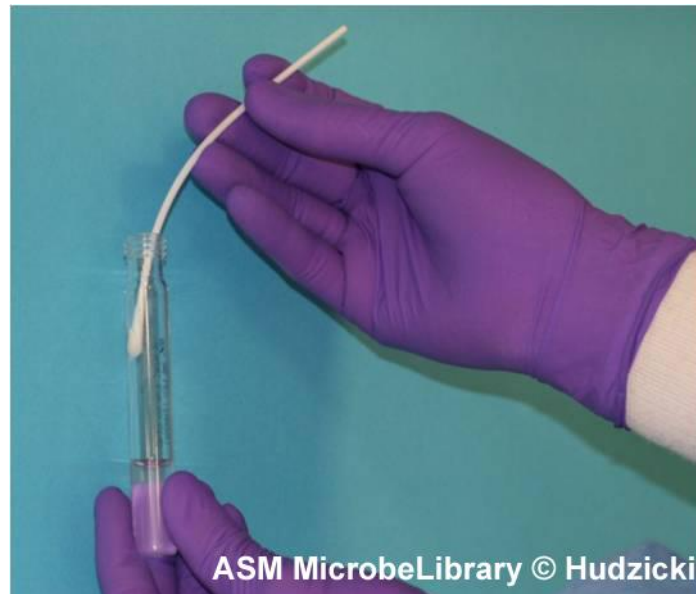

Figure showing how to rotate the swab against the side of the tube while applying pressure to remove excess liquid from the swab prior to inoculating the plate. From J. Hudzicki. 2009. Kirby-bauer disk diffusion susceptibility test protocol. American Society for Microbiology. Accessed 2018.

3. Streak the swab all over the surface of the medium three times, rotating the plate through an angle of 60° after each application.

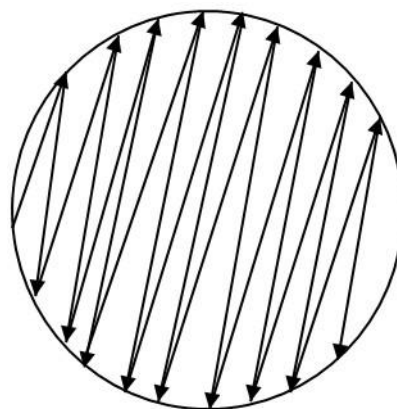

Figure of swab pattern from J. Hudzicki. 2009. Kirby-bauer disk diffusion susceptibility test protocol. American Society for Microbiology. Accessed 2018.

4. Finally, pass the swab round the edge of the agar surface.

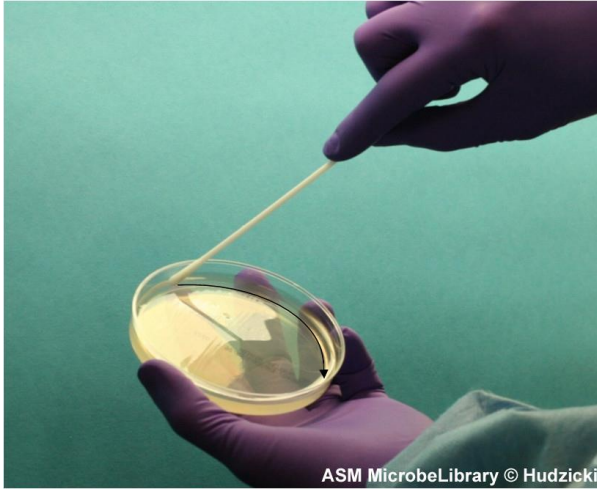
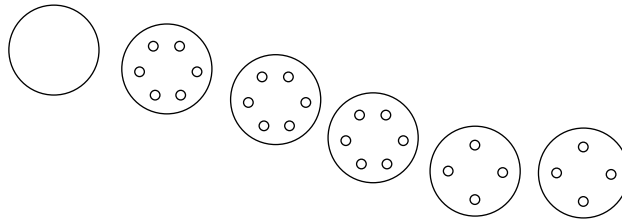

Figure showing how to rim the plate with the swab by running the swab around the edge of the entire plate to pick up any excessive liquid that may have been splashed near the edge. The arrow indicates the path of the swab. From J. Hudzicki. 2009. Kirby-bauer disk diffusion susceptibility test protocol. American Society for Microbiology. Accessed 2018.

5. Discard the swab into an appropriate container.
6. Leave the plate to dry for a few minutes (at least 3 to 5 minutes, but no more than 15 minutes) at room temperature with the lid closed.
7. The following materials will be placed on the swabbed agar. See later instructions, also.

Plate 1: Control. No other materials.
Plate 2: Discs from dispenser A.
Plate 3: Discs from dispenser B.
Plate 4: Discs from dispenser C.
Plate 5: Discs with dyes.
Plate 6: Discs with crystal violet.



8. For plates 2, 3, and 4, place the appropriate antimicrobial-impregnated discs on the surface of the agar, using the multidisc dispenser to dispense multiple discs at one time.
 - (a) To use the multidisc dispenser, place the inoculated agar plate on a flat surface and remove the lid. Place the dispenser over the agar plate.
 - (b) Press the plunger down firmly and completely to dispense the discs onto the plate.



Images showing placement of antibiotic discs using an automated disc dispenser. From J. Hudzicki. 2009. Kirby-bauer disk diffusion susceptibility test protocol. American Society for Microbiology. Accessed 2018.

- (c) Lift the dispenser off the plate, and using a sterile loop or forceps (either already sterile or sterilized by cleaning them with an alcohol pad), touch each disc on the plate to ensure complete contact with the agar surface. This should be done before replacing the petri dish lid as static electricity may cause the discs to relocate themselves on the agar surface or adhere to the lid.
 - (d) Do not move a disc once it has contacted the agar surface, even if the disc is not in the proper location, because some of the drug begins to diffuse immediately upon contact with the agar.
9. For plates 5 and 6, use sterile forceps to place four paper discs on the surface of the swabbed agar.
 10. Dip a cotton swab into one of the stains for that plate. Touch the swab to a paper disc until the disc is saturated. Repeat this procedure for the other stains.

Plate 5: methylene blue, malachite green, safranin, and carbol fuchsin
Plate 6: crystal violet 1:100, 1:1000, 1:5000, and 1:10000.
 11. Incubate the plates at 37°C.

Evaluation Instructions

1. Following incubation, measure the zone sizes to the nearest millimeter using a ruler; include the diameter of the disk in the measurement.

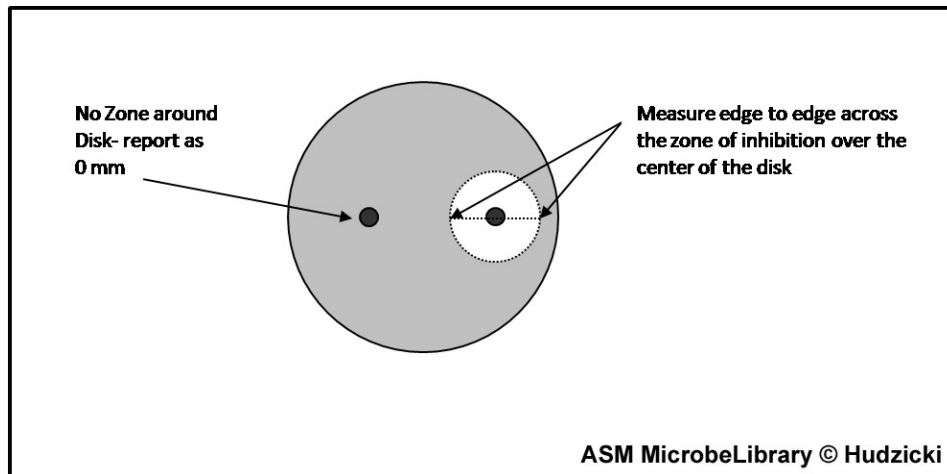

From J. Hudzicki. 2009. Kirby-bauer disk diffusion susceptibility test protocol. American Society for Microbiology. Accessed 2018.

2. When measuring zone diameters, always round up to the next millimeter.
3. All measurements are made with the unaided eye while viewing the back of the petri dish. Hold the plate about 10 cm above a black, nonreflecting surface illuminated with reflected light.

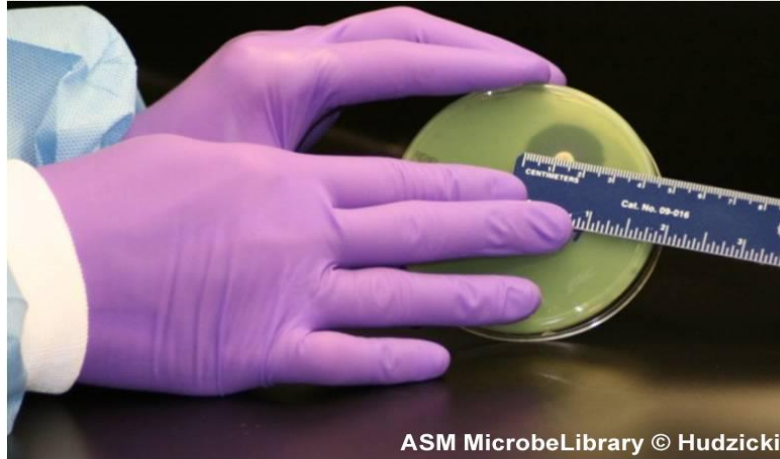

Figure showing how to use a ruler to measure each zone with the unaided eye, while viewing the back of the petri dish. Hold the plate about 10 cm above a black, nonreflecting surface illuminated with reflected light. From J. Hudzicki. 2009. Kirby-bauer disk diffusion susceptibility test protocol. American Society for Microbiology. Accessed 2018.

4. View the plate using a direct, vertical line of sight to avoid any parallax that may result in misreading.
5. To correct for any asymmetry, the diameter of the zone of inhibition should be measured at multiple locations.

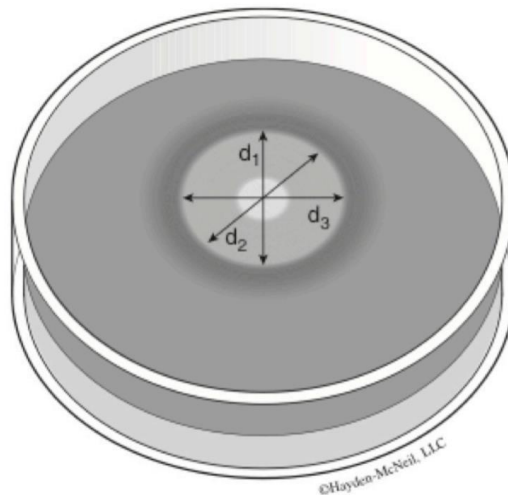
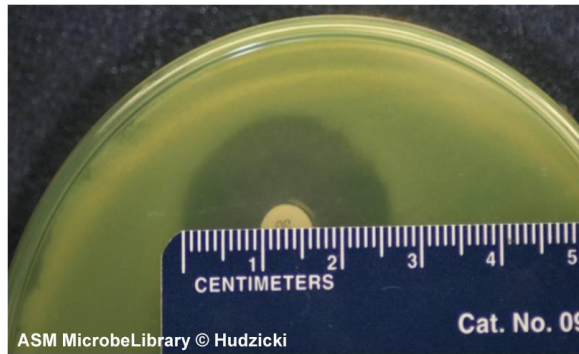

Figure showing example results from a disc diffusion experiment. The zone of inhibition is clear. The zone of inhibition is often irregularly shaped and d_1 , d_2 and d_3 are not necessarily equal. From Hester, et al. 2014. Accessed 2018.

6. Record the zone size (or average of several measurements) on the recording sheet.
7. If the placement of the disk or the size of the zone does not allow you to read the diameter of the zone, measure from the center of the disk to a point on the circumference of the zone where a distinct edge is present (the radius) and multiply the measurement by 2 to determine the diameter.



The size of the zone for this organism-antibiotic combination is 26 mm. From J. Hudzicki. 2009. Kirby-bauer disk diffusion susceptibility test protocol. American Society for Microbiology. Accessed 2018.

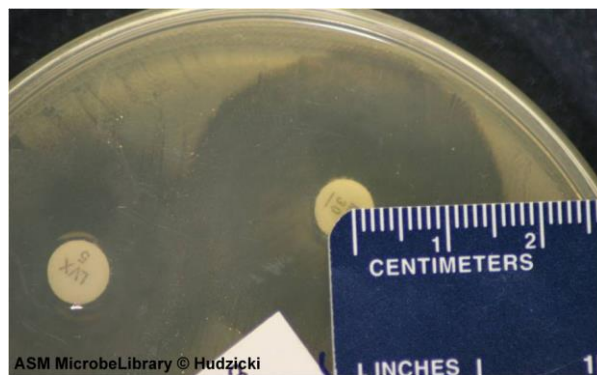

Figure showing an alternate method for measuring zones. If the zones of adjacent antibiotic disks overlap, the zone diameter can be determined by measuring the radius of the zone. Measure from the center of the antibiotic disk to a point on the circumference of the zone where a distinct edge is present. Multiply this measurement by 2 to determine the diameter of the zone of inhibition. In this example, the radius of the zone is 16 mm. Multiply this measurement by 2 to determine the zone size of 32 mm for this organism-antibiotic combination. From J. Hudzicki. 2009. Kirby-bauer disk diffusion susceptibility test protocol. American Society for Microbiology. Accessed 2018.

8. Growth up to the edge of the disk can be reported as a zone of 0 mm.
9. Organisms such as *Proteus mirabilis*, which swarm, must be measured differently than nonswarming organisms. Ignore the thin veil of swarming and measure the outer margin in an otherwise obvious zone of inhibition.
10. Distinct, discrete colonies within an obvious zone of inhibition should not be considered swarming. These colonies are either mutant organisms that are more resistant to the drug being tested, or the culture was not pure and they are a different organism. If it is determined by repeat testing that the phenomenon repeats itself, the organism must be considered resistant to that drug.
11. Sketch your plates by labeling the paper discs and drawing zones of inhibition for each plate. Include your measurements for later reference.

Plate 1 (control)

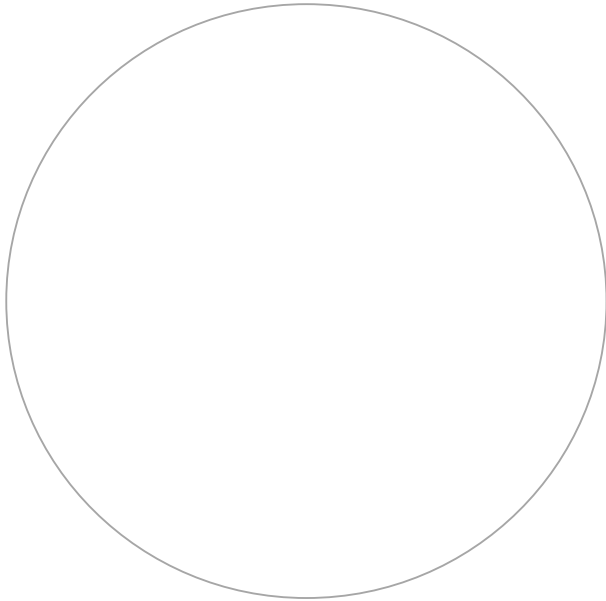

Plate 2 (dispenser A discs)

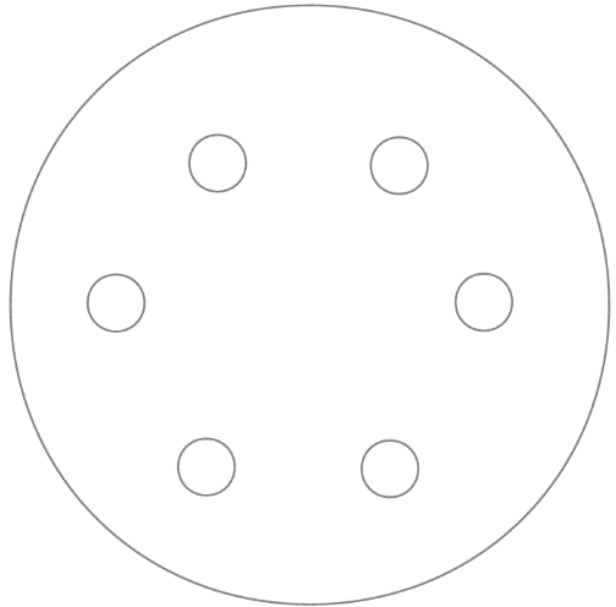

Plate 3 (dispenser B discs)

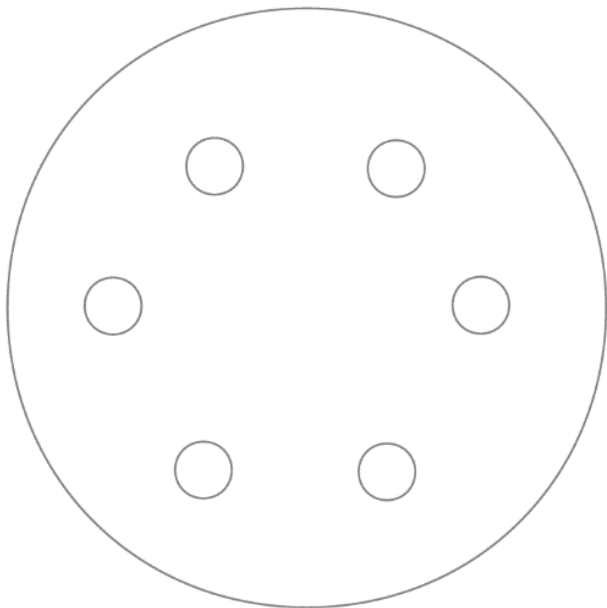

Plate 4 (dispenser C discs)

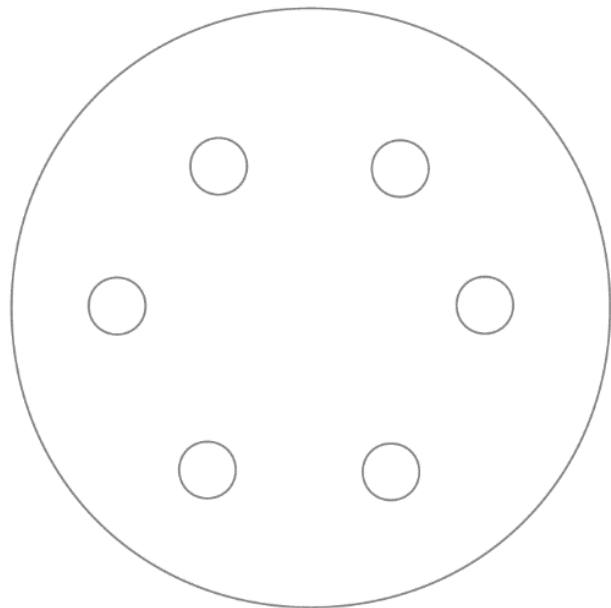

Plate 5 (stains)

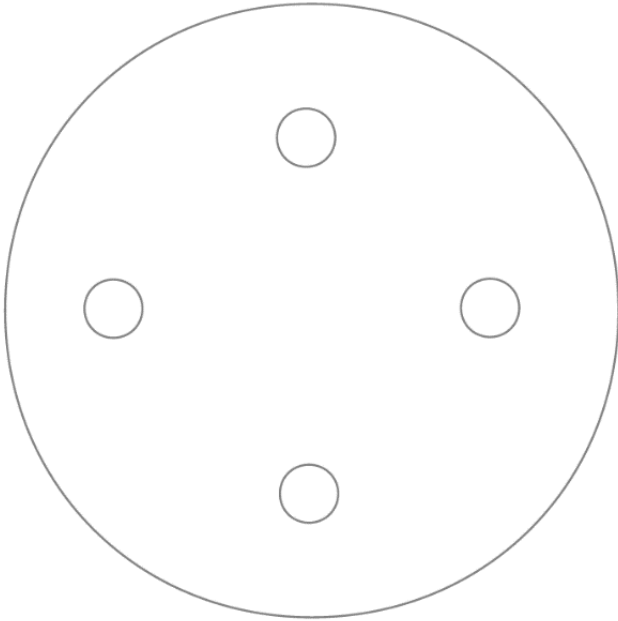
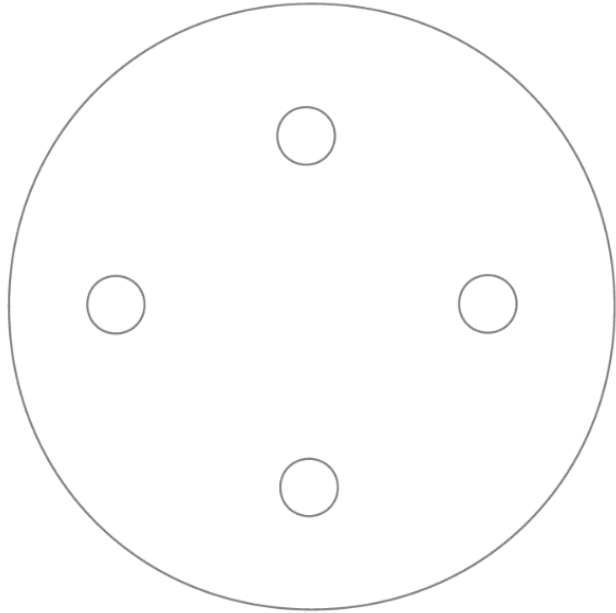

Plate 6 (crystal violet dilutions)



Dispenser	Code	Drug	Dose (μg)	Zone diameter (mm)	R, I, or S?
A	K 30	Kanamycin	30		
	Va 30	Vancomycin	30		
	E 15	Erythromycin	15		
	S 10	Streptomycin	15		
	CB 100	Carbenicillin	100		
	C 30	Chloramphenicol	30		
B	G .25	Sulfisoxazole	0.25		
	D 30 / DO 30	Doxycycline	30		
	CF 30 / CR 30	Cephalothin	30		
	Am 10	Ampicillin	10		
	Tmp 5	Trimethoprim	5		
	Te 30	Tetracycline	30		
C	Ox 1	Oxacillin	1		
	Cip 5	Ciprofloxacin	5		
	Fox 30	Cefoxitin	30		
	P 10	Penicillin	10		
	Azm 15	Azithromycin	15		
	Gm 10	Gentamycin	10		

Interpretation Instructions

1. Consult the chart to determine the susceptibility or resistance of the organism to each drug tested. Note that sometimes there are different lines for different organisms. If a group of organisms is not listed for a particular drug, that drug is probably not typically used against that group of organisms, and the organism is likely to be resistant.
2. For each drug, indicate on the recording sheet whether the zone size indicates susceptibility (S), intermediate susceptibility (I), or resistance (R), based on the interpretation chart.
3. If the drug is not on the chart, just report the size of the zone of inhibition. Dyes and coins are not on the charts either, so just report those zone sizes.
4. Record your results on the chart, and be prepared to post results for your classmates.
5. Copy the results of all teams when posted.

Drug	Zone diameter, nearest whole mm		
	Resistant	Intermediate	Susceptible
Ampicillin, 10 µg			
when testing gram-negative enteric organisms	≤ 13	14-16	≥ 17
when testing staphylococci	≤ 28	--	≥ 29
when testing <i>Haemophilus</i>	≤ 21	22-24	≥ 25
when testing enterococci	≤ 16	17	--
when testing non-enterococcal streptococci	≤ 21	22-29	≥ 30
when testing <i>L. monocytogenes</i>	≤ 19	--	≥ 20
Azithromycin, 15 µg	≤ 13	14-17	≥ 18
Carbenicillin, 100 µg			
when testing <i>Pseudomonas</i>	≤ 13	14-16	≥ 17
when testing others (usually gram-negative)	≤ 19	20-22	≥ 23
Cefoxitin, 30 µg	≤ 14	15-17	≥ 18
Cephalothin, 30 µg	≤ 14	15-17	≥ 18
Chloramphenicol, 30 µg	≤ 12	13-17	≥ 18
Ciprofloxacin, 5 µg	≤ 15	16-20	≥ 21
Doxycycline, 30 µg	≤ 12	13-15	≥ 16
Erythromycin, 15 µg	≤ 13	14-22	≥ 23
Gentamycin, 10 µg	≤ 12	13-14	≥ 15
Kanamycin, 30 µg	≤ 13	14-17	≥ 18
Oxacillin, 1 µg	≤ 10	11-12	≥ 13
Penicillin, 10 µg			
when testing staphylococci	≤ 28	--	≥ 29
when testing enterococci	≤ 14	15	--
when testing <i>L. monocytogenes</i>	≤ 19	--	≥ 20
when testing non-enterococcal streptococci	≤ 19	20-27	≥ 28
Streptomycin, 10 µg	≤ 11	12-14	≥ 15
Sulfisoxazole, 0.25 µg	≤ 12	13-16	≥ 17
Tetracycline, 30 µg	≤ 14	15-18	≥ 19
Trimethoprim, 5 µg	≤ 10	11-15	≥ 16
Vancomycin, 30 µg			
when testing enterococci	≤ 14	15-16	≥ 17
when testing other gram-positive organisms	≤ 9	10-11	≥ 12

Source: Hardy Diagnostics, Antimicrobial Sensitivity Test. Accessed 2019.

Drugs results: Record S, I, or R for these antibiotics.

Team	Organism	K 30	Va 30	E 15	S 10	CB 100	C 30	G .25	D 30 / DO 30	CF 30 / CR 30	Am 10	Tmp 5	Te 30	Ox 1	Cip 5	Fox 30	P 10	Azm 15	Gm 10	
A																				
B																				
C																				
D																				
E																				
F																				

Dyes and Coins results: Record the zone diameter in mm.

Team	Organism	MB	MG	S	CF	CV 1:100	CV 1:1k	CV 1:5k	CV 1:10k
A									
B									
C									
D									
E									
F									

Summary

Organism	Gram-stain	Total number of susceptibilities (S)

Review questions

1. Why was it important to have a control plate containing only the assigned organism?
2. Was your control plate positive, or negative, for growth? What significance would it have for your experiment if the control plate was negative?
3. Define “antimicrobial agent.”
4. Why is it essential to completely cover the plate with bacteria before performing susceptibility testing?

5. Which antimicrobial substances seemed to be effective at controlling the growth of your team's organism?

6. Which drugs exhibited the behavior of broad-spectrum agents?

7. What is the mode of action of penicillin?

8. What is the mode of action of ciprofloxacin?

9. How do the modes of action of penicillin and ciprofloxacin help explain your overall data?

10. Are antibacterial drugs useful for treating viral infections? Why or why not?

11. Why are pure cultures necessary for performing antimicrobial susceptibility testing?

12. What is antimicrobial susceptibility?

13. What is antimicrobial resistance?

14. How can we delay the development of drug resistance in bacteria?

15. The results below were obtained from a disc-diffusion test against a bacterial species. Which drug looks like the best choice for treating an infection from this organism? Why do you say so?

Antibiotic	Zone of inhibition (mm)
A	0
B	12
C	5
D	12

16. If a hospital lab isolates *Staphylococcus aureus* from several patients on the same day, is it necessary to test the susceptibility of each isolate? Why or why not?

Exercise 15: Heat, Cold, Drying, and Radiant Energy

Objectives

Demonstrate the effectiveness of these control methods against common microorganisms.

Introduction

Just as there is a great deal of diversity in the metabolic properties of bacteria, there is also a great deal of diversity in the types of environments in which different species of bacteria can survive. Microbes are affected in different ways by their physical environment. In today's lab you will perform experiments that will determine the effects of some of these physical factors on microbial growth.

Effect of temperature

Prokaryotes are found in all types of environments. Some microbes are adapted to live in very cold temperatures, whereas others can survive only in very hot temperatures. Each species has a minimum temperature (lowest temperature for growth), maximum temperature (highest temperature for growth) and optimal temperature (temperature at which it grows best).

Because microbial growth can be affected by temperature, both high and low temperatures can be used to control the growth of microorganisms.

Low Temperatures: Low temperatures are primarily bacteriostatic—they inhibit bacterial growth and/or reduce the total number of bacteria. Low temperatures inhibit enzyme activity, so biochemical reactions are slowed or cease, thus reducing the rate at which the bacteria can metabolize and reproduce. This inhibition of enzymatic activity is usually not permanent—if the temperature increases, the enzymes can function at their normal rate, and the bacteria will resume metabolizing and reproducing. Low temperatures are commonly used to prevent food from “spoiling”—i.e., to inhibit bacterial growth, but low

temperatures cannot be used to sterilize materials.

High Temperatures: High temperatures can be bactericidal—they can kill bacteria. Heating your inoculating loop in the Bacti-Cinerator results in sterilization, since the bacteria are incinerated. Not all materials can be sterilized by incineration, so both *dry heat* methods and *moist heat* methods can be used to kill bacteria. Dry heat kills by causing oxidation of cellular molecules and by desiccating (drying) the bacteria. Dry heat is commonly used to sterilize materials that could be damaged by moisture (corrosive metal surgical instruments, dry powders). Dry heat methods generally require longer times and higher temperatures, and are less penetrating than moist heat methods. For example, the hot air oven requires two hours at 160 – 180°C to sterilize materials.

Moist heat works by denaturing nucleic acids and enzymes in the bacteria; once these molecules are denatured they are no longer capable of functioning, so even if the temperatures are reduced, the bacteria are incapable of metabolizing or reproducing. Moist heat methods include boiling, pasteurization, and autoclaving.

1. **Boiling:** The temperature of boiling water at sea level is 100°C. This temperature is high enough to kill many vegetative cells, but the exact time required varies depending on the bacterial species. Boiling does not guarantee sterilization, because some bacteria can produce spores that are resistant to high temperatures.

2. **Pasteurization:** Pasteurization is a heating method that is used to control the growth of microbes in food materials such as milk and fruit

juices. Regular pasteurization (the holding or batch method) is a low heat treatment (63°C for 30 min.) that is used to reduce the number of bacteria to what are considered to be acceptable levels. It is primarily focused on eliminating *Mycobacterium tuberculosis*, *Escherichia coli*, and *Salmonella* sp. from milk. More recently, two other pasteurization methods have been developed: flash pasteurization (71.6°C for 15 sec) and the ultra-high temperature (UHT) method (140°C for 3 sec.) The UHT method can sterilize if it is done under proper aseptic conditions.

3. **Autoclave:** The autoclave is an instrument that uses steam under pressure to destroy microbes. An autoclave is generally set to apply 15 lbs/in² of pressure, which allows liquids inside the autoclave to reach a temperature of 121.5°C, a higher temperature than can be achieved by a liquid at normal atmospheric pressures. Autoclaves are capable of achieving sterilization—killing all forms of life, including viruses and spores. They are commonly used in the laboratory to sterilize growth media, glassware, and other solutions. They are used in hospital settings to sterilize bedding, IV solutions, instruments, and other heat-resistant objects.

Since heating methods are commonly used to control microbial growth, it is important to be able to define the effectiveness of a heating method for a particular bacterial species. One way to do this is to determine the thermal death time (TDT). The TDT is the minimum time it takes to kill a population of microbes at a specific temperature.

Effect of moisture

All living organisms, including bacteria, require water to survive. However, bacterial species vary in their ability to survive in a dry environment. Although some species will die very quickly under dry conditions, others can persist for varying amounts of time. The bacterial endospore is not affected by dry conditions, and can germinate to form vegetative cells when it finds itself in a moist environment. Other non-spore-formers can also persist in the environment for varying amounts of time based on their cell wall properties and amount of glycocalyx they produce.

Effect of UV radiation

Ultraviolet (UV) radiation is electromagnetic radiation or light, having a wavelength longer than that of x-rays but shorter than that of visible light (between 100 nm - 400 nm). UV radiation damages the DNA molecule by causing the formation of pyrimidine dimers, which are unnatural bonds between adjacent thymine or cytosine nucleotides. These bonds distort the DNA molecule, which can interfere with the processes of DNA replication and transcription.

Although cells do have repair mechanisms to fix the damage, DNA damage caused by UV radiation exposure (particularly in the range of 240-260 nm) can result in mutations, and long-term exposure can overwhelm the repair mechanisms and cause cell death. UV radiation is used to control microbial growth in such locations as sterile hoods, operating rooms, and other areas when these areas are not in use. People need to use these methods with caution, as the UV radiation can damage skin cells as well.

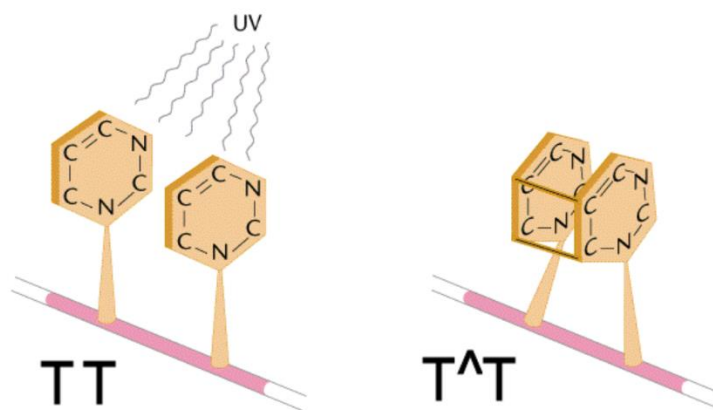

Effect of UV light on a strand of DNA. Thymine dimers are produced when adjacent thymidine residues are covalently linked by exposure to ultraviolet radiation. Covalent linkage may result in the dimer being replicated as a single base, which results in a frameshift mutation. From Steven M. Carr. 2011. Thymine-thymine dimers. Accessed 2019.

Materials, per team

- 9 tubes of T-soy broth
- 1 sterile blank
- 5 T-soy plates
- Sterile swabs
- Broth culture of a bacterium to test

Instructions

All work for this lab will be completed as a team. Each table will be working with a different organism. We will later share all results with the class.

Heat:

1. Label seven T-soy broth tubes, #1-7, high up on the tube (just below the lid).
2. Inoculate all seven tubes with a loop of your organism.
3. Treat each tube as follows:
 - Tube 1: Control. No heat.
 - Tube 2: Pasteurize in 63°C water bath for 10 minutes.
 - Tube 3: Pasteurize in 63°C water bath for 20 minutes.
 - Tube 4: Pasteurize in 63°C water bath for 30 minutes.
 - Tube 5: Boil in 100°C water bath for 1 minute.
 - Tube 6: Boil in 100°C water bath for 5 minutes.
 - Tube 7: Boil in 100°C water bath for 10 minutes.
4. After any heating, cool each tube in a beaker of tap water for a few minutes.
5. Incubate tubes at 37°C.

Cold:

1. Label two remaining T-soy broth tubes.
2. Inoculate both tubes with a loop of your organism.
3. Refrigerate one tube, and freeze the other.

Drying:

1. Label the sterile blank.
2. Place one loop of your organism in the bottom of the sterile blank.
3. Incubate tube at 37°C. (This will dry out the organism.)

Radiant Energy:

1. Label the T-soy plates. Be sure to label the underside of the plate with which half will be covered by glass.
2. Use a swab to thoroughly inoculate the entire surface of all five plates with your assigned organism. Dispose of swab properly.
3. Treat each plate as follows:

For plates 2 – 5, remove the lid during exposure. Cover half of the open plate with a piece of glass. This will enable us to determine whether the glass blocks any effect of the radiant energy.

Plate 1: Control. No special treatment.

Plate 2: Place in sunlight for 10 minutes.

Plate 3: Place under visible light for 10 minutes.

Plate 4: Place under UV light for 10 minutes.

Plate 5: Place under infrared light for 10 minutes.

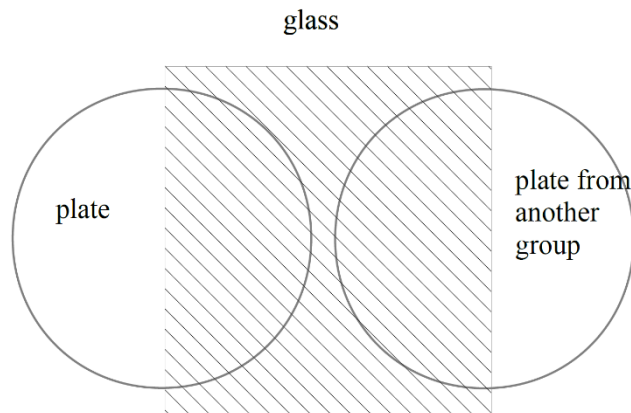

4. Close the lids, and incubate the plates at 37°C.

Next lab meeting:

When you return to lab, the drying, refrigeration, and freezing treatments require additional steps.

Drying tube:

5. Examine the dried tube for growth. (You are not likely to see anything.)
6. Use aseptic technique to pour T-soy broth into the dried tube, and incubate at 37°C. (If the tube shows growth after some more time incubating with the broth, then the bacteria were still alive after being dried!)

Refrigeration and freezing:

7. Allow tubes to come to room temperature to evaluate them for growth. Then, incubate the tubes at 37°C to find out whether the bacteria are still alive.

Waiting around?

Y G R E N E E R U S S E R P L
V C I T A T S O I R E T C A B
P A S T E U R I Z A T I O N Y
V W H T G N E L E V A W A D B
R O N O I T A Z I L I R E T S
G L Y C O C A L Y X A Z N Z W
R E F R I G E R A T I O N Q A
A Y B A C T E R I C I D A L B
M T G E R U T A R E P M E T C
U I N B U L T R A V I O L E T
M V I Z N R E V A L C O T U A
I I Y T H K A E N Z Y M E W K
X T R E N D O S P O R E R O A
A C D H A N O I T I B I H N I
M A D E R A R F N I I U Y Q F

PASTEURIZATION MAXIMUM
DRYING WAVELENGTH
ULTRAVIOLET ENDOSPORE
INFRARED GLYCOCALYX
BACTERIOSTATIC SWAB
BACTERICIDAL
TEMPERATURE
AUTOCLAVE
REFRIGERATION
ENERGY
ENZYME
ACTIVITY
STERILIZATION
INHIBITION
PRESSURE

Evaluation of results

1. Examine all tubes for growth. Record as “+” for growth, or “-“ to indicate no growth. If a tube looks negative, give it a swirl to check for growth that has settled to the bottom.
2. Examine all plates for growth. Record as light, medium, heavy, or negative. As a reference point, the control plate has a sheet of heavy growth. (Sometimes a plate with individual colonies will look heavier than the control plate, but these colonies grew from single cells, so the growth is actually lighter than a solid sheet.)
3. Share your results with the class.

Record “+” for growth, or “-“ for no growth.

Organism	Control	Pasteurize (min.)			Boil (min.)			Refrigerate	Freeze	Dry
		10	20	30	1	5	10			

Record as light growth (L), medium (M), heavy (H), or negative (N).

Organism	Control	Sunlight		Visible light		Ultraviolet		Infrared	
		Open	Covered	Open	Covered	Open	Covered	Open	Covered

Review questions

1. Why are control cultures important in these experiments?
2. What are possible unexpected results?
3. How might you explain these unexpected results?
4. Define pasteurization.
5. What is the purpose of pasteurization?
6. Did some bacteria seem to be more resistant to heat, compared with others? Why do you think this was the case?

Name _____

Date _____

Section # _____

Exercise 16: Antibacterial Products

Objectives

Compare effectiveness of disinfectants, antiseptics, and cleaning products. Demonstrate the importance of time, concentration, and species.

Introduction

The use of chemicals to control microbial growth dates back at least as far as the 1800s. Tincture of iodine was used as antiseptic during the Civil War, and Joseph Lister established the practice of aseptic surgery using a disinfectant known as carbolic acid (phenol) in the 1860s. Since that time, many types of disinfectants (agents that are used to eliminate or kill vegetative cells on surfaces) and antiseptics (agents that are used to eliminate or reduce vegetative cells on living tissue) have been used. Although disinfectants and antiseptics may be effective at killing vegetative cells, they do not usually achieve sterilization.

Various factors need to be considered when choosing a disinfectant or antiseptic. It is very important to know which microbes are present to

determine what type of disinfectant would work best. It is also important to realize that the effectiveness of a particular disinfectant may be affected by pH, temperature, concentration, and exposure time. Ideal disinfectants should be effective against the particular contaminants present, usable at a low concentration, require a relatively short exposure time, and have a long shelf life. It should also be water soluble, non-toxic to humans and animals, and cost-effective.

In this lab you will test the amount of time required for a particular product to kill various bacterial species. Each bacterial species will be exposed to the product for 2, 5, and 10 minutes, and “rescued” from the product after that time to detect whether the bacteria are still alive.

Materials, per student

- Bring at least 20 mL of a liquid antibacterial product from home or work.
- Three sterile blank tubes
- Beaker to dilute product, if needed
- One 5 mL or 10 mL pipette
- Three 1 mL pipettes
- Nine T-soy broths
- Cultures, per table:
 - *E. coli* broth culture, 24 hours old
 - *Pseudomonas aeruginosa* broth culture, 24 hours old
 - *Bacillus* sp. broth culture, more than 24 hours old

Instructions

- Record your product information.

Product name: _____

Active ingredient(s), with concentration, if given: _____

Required dilution of product, if any: _____

- If necessary, dilute your product to the normal usage strength. (Most products are not diluted.)
Hint: If the label instructions are given in non-metric units, try substituting milliliters for ounces. One cup = 8 oz., and one gallon = 128 oz. Therefore, if the dilution is $\frac{1}{4}$ cup of product per gallon of water, this is 2 oz. per 128 oz. You can instead use 2 mL of product per 128 mL of water.
- Label the sterile blanks with the names of the three bacteria you will be testing.
- Label the broth tubes with your name, lab section, and product name. Label three tubes for each bacterial species. Each bacterial species should have a tube for 2, 5, and 10 minutes of exposure to the product.
- Using a 5 mL or 10 mL pipette, add 5 mL of diluted product into each of the three sterile blank tubes.
- Choose one bacterial species to test first. (Inoculating all three species simultaneously makes it too difficult to track the time intervals.) Using a 1 mL pipette, add 0.5 mL of that organism's broth culture into one tube of product.
- Roll the tube between your hands to mix, and start timing.
- After a total of 2 minutes, 5 minutes, and 10 minutes, dip in a sterile loop to rescue some bacteria from the product. Transfer each loop to the appropriate labeled broth tube.

E. coli

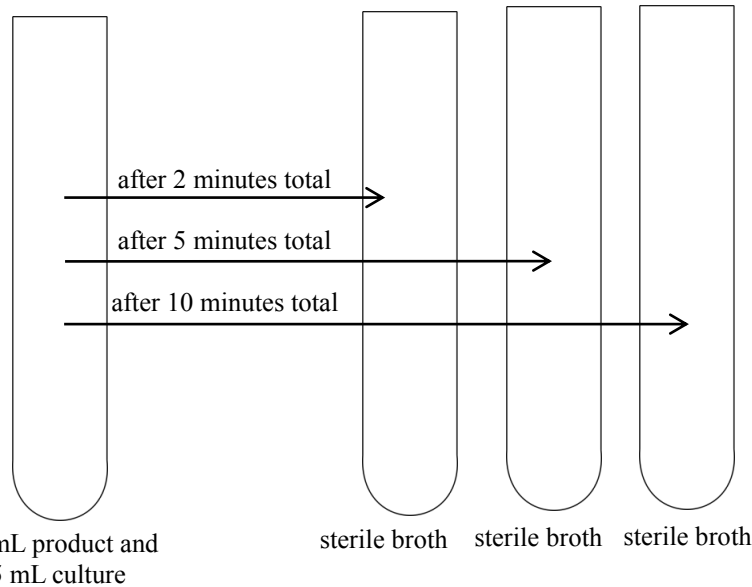

Pseudomonas

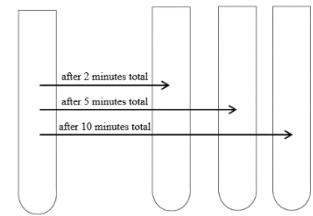

Bacillus

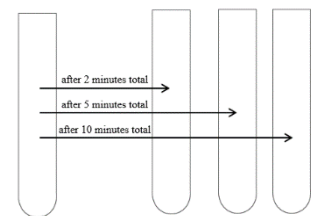

Review questions

1. What were the results from your control tubes?
2. Why is it important to have control tubes in this experiment?
3. Imagine that one of your control tubes is negative for growth. What would this mean for how you interpret your results for that organism?
4. Was this a fair test of your product? Why do you say so?
5. What is the difference between an antiseptic and a disinfectant?
6. Name two examples of each.
Antiseptic:

Disinfectant:
7. Which of the organisms in this test would you imagine would be most difficult to control? Why?

Part 7: Epidemiology and Immunology

Exercise 17: HIV Epidemic and Detection with ELISA

Objectives

Take part in a synthetic epidemic, use ELISA to detect HIV antibodies, and use epidemiology to learn source of epidemic.

Introduction

Epidemiology is the study of the spread of disease. As a result, an epidemiologist searches out the origins of infections, so that diseases might be better controlled. In this lab we will participate in a synthetic epidemic of HIV, using a harmless fluid. We will use a test called ELISA to detect antibodies against HIV, since this antibody production can be indicative of an infection. We will also try to determine the source of the epidemic.

The rapid and accurate diagnosis of infectious disease is often crucial to determining patient treatment, supportive care, and precautions for the health care worker. However, some infectious diseases are more easily diagnosed than others. For example, although many types of bacteria may be easily identified by appearance on differential media, gram staining, metabolic testing, etc.... these identification methods may be time-consuming and are not always practical. In addition, not all pathogens (e.g., viruses) can be cultured in the laboratory, and so other types of diagnostic tests are necessary.

Our immune systems respond to the presence of antigens (a foreign substance that stimulates an immune response) by producing antibodies (globular proteins produced and secreted by B lymphocytes) that bind specifically to them. Many diagnostic tests take advantage of the specificity of antigen-antibody binding to detect exposure to a particular pathogen. For example, some diagnostic tests detect antibodies in a patient's serum— their presence indicates exposure to a specific pathogen,

as these antibodies will only be present if the patient has been exposed to that pathogen. Other diagnostic tests may look for specific antigens in serum (or in a cultured clinical sample) by reacting them with known antibodies in clinical laboratory tests.

The Enzyme-linked Immunosorbent Assay (ELISA) is used to detect several types of pathogens and is particularly useful for the diagnosis of viral infections. Although there are many variations of this test, it is most commonly used to detect serum antibodies to a particular viral pathogen. ELISAs are used to diagnose exposure to human immunodeficiency virus (HIV), Epstein-Barr virus (EBV) and several other pathogens. The test typically uses 96-well plates that have viral antigens bound to the wells. When serum is added, only antibodies that are specific to the antigen in the well will bind to it—all other serum components (including other types of antibodies) will be removed during washing steps. A secondary antibody (one that recognizes the first antibody) is then added. This secondary antibody is conjugated (attached) to an enzyme (horseradish peroxidase is one commonly used enzyme). After washing away unbound secondary antibodies, the enzyme's substrate is added, and produces a color reaction in the well (this is known as colorimetric detection). A color change is an indication of serum antibody, which means that the patient has been exposed to that particular pathogen. Further testing may be done to confirm a positive ELISA test.

Diagram of ELISA

1. Add Ag (▲) to wells

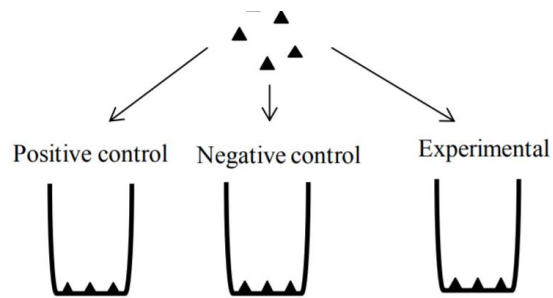

2. Add control Ab (⌒) to positive control, no Ab to negative control and patient serum to experimental well

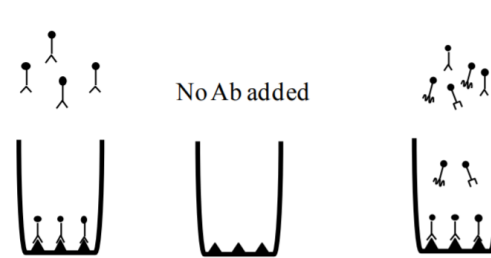

3. Add 2° Ab (⌒) coupled to enzyme

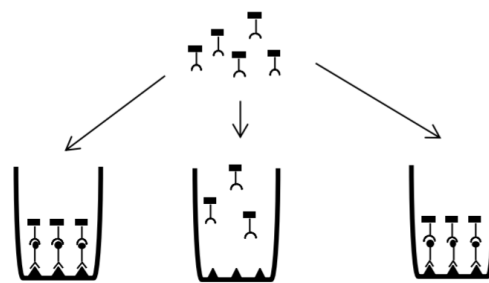

4. Add substrate (⊖)

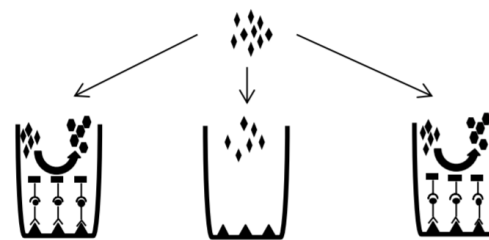

Result: if there is a positive result, a colored product (●) is produced

Enzyme acts on its substrate, producing colored product

Enzyme not present; no colored product produced

If seropositive, enzyme acts on its substrate, producing colored product

Figure of ELISA test. In our test, the HIV antigen is already adhered to the bottom of the microtiter plate wells. From Petersen, J. and S. McLaughlin. 2016. Laboratory Exercises in Microbiology: Discovering the Unseen World Through Hands-On Investigation. CUNY Academic Works. Accessed 2018.

Background quiz on HIV/AIDS

	TRUE	FALSE	I don't know
<ol style="list-style-type: none"> 1. HIV can lead to AIDS if the HIV is untreated. 2. Anyone can be infected by HIV, not just homosexual men, prostitutes, or injection drug users. 3. An HIV-infected woman can pass the virus to her unborn baby. 4. HIV attacks the body's defense system and eventually makes a person more vulnerable to other infections. 5. HIV can be transmitted through oral sex. 6. Anal sex and penile-vaginal intercourse are more likely to transmit HIV than oral sex. 7. Being HIV-negative means that you don't currently have an active HIV infection. 8. A baby can get infected with HIV through breastfeeding. 9. It is safe to use toilet seats that have been used by people with HIV infections. 10. It is safe to share drinking glasses with people with HIV infections. 11. Coughs and sneezes from people with HIV infections are the same as from anyone else. 12. It is possible to acquire an HIV infection through a single act of unprotected sex with an HIV-infected person. 13. Having a different sexually-transmitted infection can increase the likelihood of acquiring HIV through unprotected sex. 14. Married people can become infected with HIV. 15. It is possible to be HIV-infected and unaware of it. 16. The presence of HIV antibodies can indicate HIV infection. 17. Condom use reduces the likelihood of HIV infection, but condoms are not 100% effective. 18. Women on birth control can become infected with HIV. 19. It is safe to give blood with sterile needles. 20. HIV can remain active outside of the body for hours if dry, and for weeks if wet (such as in a used syringe). 21. The myth that "sex with a virgin will cure AIDS" is prevalent in sub-Saharan Africa. 22. Saliva carries a negligible viral load, so even open-mouthed kissing is considered a low risk. 23. People with HIV look just like everyone else. 24. The first HIV infection likely arose in hunters who came into blood-contact with dead monkeys infected with simian immunodeficiency virus (SIV). 			

Answers to quiz: True is correct for all of these statements.

Before coming to lab, respond to the following:

1. Define antigen:
2. Define antibody:
3. How do B cells and T cells work together in our adaptive immune system?
4. HIV destroys CD4+ T cells. How does this compromise the immune system?
5. How does HIV target a specific type of T cell?
6. Briefly describe the three clinical stages of an untreated HIV infection.
7. Explain the difference between latent and active HIV infections in CD4+ T cells.
8. Why can the onset of AIDS take several years?

Materials, per team

- One plastic tube of simulated body fluid, per student
- Dropper bottle of positive solution
- Dropper bottle of negative solution
- Dropper bottle of enzyme-linked secondary antibody
- Dropper bottle of washing solution
- Plastic tube of substrate / color reagent solution / TMB
- Microtiter plate
- Pipettes
- Lab coats and gloves

Instructions

1. Take a plastic tube containing 1 mL of “body fluid,” along with a transfer pipette.
2. Wait for clearance from your instructor before proceeding.
3. To simulate sexual interactions, exchange half of the volume of your tube with other consenting students in the room. Make new friends!
4. After all of your interactions, we will need to wait several months for antibodies to develop...
5. Now for the ELISA: Place your microtiter plate on a piece of paper towel and label the rows with the people at your table.
6. Draw the layout of the microtiter plate. Include labels for the people at your table, along with rows for positive and negative controls.

Example:

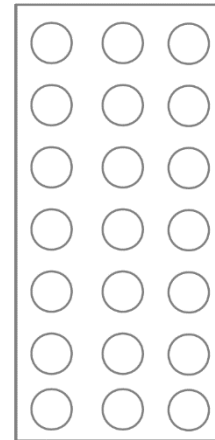
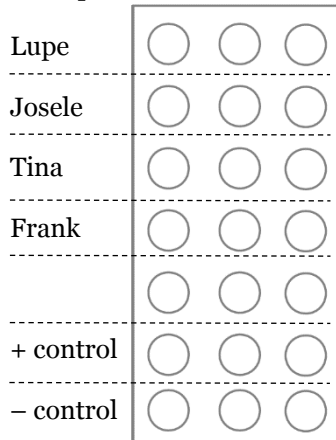

7. Find your row of the plate. Use your pipette to add three drops of your body fluid into each of the three wells in your row of the plate (using a total of nine drops). Have each person do this for just their row.
8. In the positive control row, add two drops of the positive test solution into each of the three wells in that row. In the negative control row, add two drops of the negative test solution into each of the three wells in that row.
9. Let the microtiter plate sit undisturbed for five minutes. This allows any HIV antibodies to link to the HIV antigen at the bottom of the wells.

10. Remove excess liquid by shaking the entire plate out in a sink.
11. Use the dropper bottle of washing solution to rinse the entire plate three times. Shake off excess liquid again.
12. Add two drops of enzyme-linked secondary antibody to each well, including the positive and negative control rows.
13. Let the plate sit undisturbed for another five minutes.
14. Repeat steps 10 and 11.
15. Add two drops of TMB to each well, including the positive and negative control rows.
16. Watch your plate for the next five minutes. What happens? Draw and label your observations.

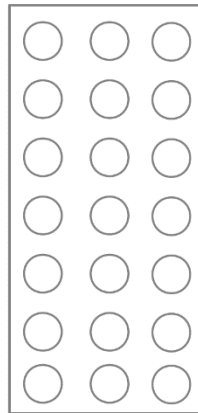

17. What is the color of an HIV-positive result?
18. What is the color of an HIV-negative result?
19. How many people at your table are positive for HIV? (Note: In real life, if the ELISA returns a positive result, a Western blot is performed to confirm.)
20. Why were both positive and negative controls needed?

Review questions

1. How many students are in your class today?
2. Based on the ELISA, how many are positive for HIV?

What percentage are therefore positive?

3. What might it feel like to be the person who started the epidemic (also known as “patient zero”) for a population?
4. How do you determine who was “patient zero”?
5. Who in your lab was “patient zero”?
6. In real life, why might someone avoid getting tested for HIV?
7. Is it true that when you have sex with someone, you are also having sex with all of their previous partners? Discuss this idea.

8. What are some factors that influence the likelihood of HIV transmission?

9. What are some other sexually-transmitted pathogens?

10. How do you think the number of sexual interactions influences the overall number of STI cases in a given population?

11. How can you protect yourself from acquiring HIV?

What method is 100% effective?

12. What are your thoughts on these recommended strategies for reducing HIV transmission?
 - Advocating that people reduce their number of concurrent / simultaneous partners.

 - Teaching about safe sex and contraceptives.

 - Teaching about medications to prevent or limit transmission, or help control HIV.

- Offering free HIV testing.

13. Abstinence-only sex education programs have not been effective, neither is there evidence that abstinence-only, or abstinence-only-until-marriage programs actually lower risky sexual behavior in teens¹. What do you think young people should be taught instead?

ELISA review

1. Describe the mechanism of an indirect ELISA, with the importance of each step.
2. HIV infections are usually confirmed with Western blotting. What is the Western blot?
3. The ELISA test has been a standard procedure for detecting HIV infections. There are now tests that detect viral RNA. When would these tests be useful? Why? (It may help to look up the “window period.”)

¹ K. L. Wilson, et al. 2012. Adoption and implementation characteristics for abstinence-plus curriculum. American Journal of Health.

Part 8: Microbial Genetics

Exercise 18: Bacterial Transformation

Objectives

Perform genetic transformation of *E. coli* with a jellyfish gene that codes for a fluorescent protein.

Introduction

The ability to transform bacteria can be traced back to 1928 with Frederick Griffith's experiment using *Streptococcus pneumoniae*¹, a bacterium that causes respiratory disease in mammals. In that study, Griffith worked with two strains of *S. pneumoniae*, a pathogenic encapsulated smooth strain (smooth refers to the glistening appearance of colonies on artificial media) and a nonpathogenic nonencapsulated rough strain with no glistening appearance. Mice infected with the smooth strain died whereas mice infected with the rough strain survived. Mice infected with heat-treated smooth strain survived. When Griffith mixed live rough strain with killed heat-treated smooth strain and infected the mice, the animals died. Clearly, some genes from the dead bacteria were transferred to the rough strain causing the harmless bacteria to become encapsulated and therefore pathogenic. Griffith called the phenomenon transformation.

Oswald Avery provided a molecular explanation for this process in the 1930s and 1940s. Avery and his colleagues determined the chemical identity of these capsules. He and others at the Rockefeller Institute showed that transformation can also occur in a test tube by mixing crude DNA extract with living rough cells. Avery and his colleagues isolated and identified a substance within the bacterial extract that was the "transforming principle" causing a heritable change in bacterial cells. The transforming principle is known today as deoxyribonucleic acid, or DNA.

Today, chemically-induced transformation is commonly used in many laboratories. Some strains of bacteria are not naturally transformable but can be artificially induced to take up DNA by chemical

or electrical shock methods. In the early 1970s, Mandel and Higa demonstrated that bacteriophage DNA can be transferred to *Escherichia coli* K12, a strain that is not naturally transformable, by addition of calcium chloride. Since then, many laboratories have modified the original methods with the goal of increasing transformation efficiency.

Chemically-induced competence followed by transformation is a commonly used technique to introduce plasmids or other DNA fragments into *Escherichia coli*. Depending on the genetic information it carries, the incoming DNA can be replicated as an independent entity or integrated into the host chromosome. To select for cells that incorporate the DNA, a plasmid is engineered to carry selectable markers such as antibiotic resistance genes. Plasmid uptake provides the host cell with the ability to survive on a selective media. Transformation of cells with DNA is an invaluable technique that provides scientists with a way to introduce and manipulate genes.

Genetic transformation is used in many different areas. In agriculture, the technology is used to give plants the ability to resist spoiling, freezing, drought, and pests. In bioremediation, bacteria can be given the ability to digest oil spills or take up harmful metals. In medicine, some genetic disorders are being treated through gene therapy, which transforms the sick person's cells with healthy versions of the pathogenic gene.

In this lab we will transform *E. coli* with a gene that codes for green fluorescent protein (GFP). The original source of the gene is the bioluminescent sea jelly *Aequoria victoria*. The sea jelly can

¹ Griffith, Fred. 1928. The Significance of Pneumococcal Types. *Journal of Hygiene*. Cambridge University Press. 27 (2): 113–159.

produce blue light with a protein called aequorin, and when GFP absorbs the blue light, the GFP glows green. (You may wonder why the sea jelly does this, when the color could attract a predator? Well, the color seems to also attract mates!) If we are successful in giving *E. coli* the ability to produce GFP, the bacteria may glow green when we shine a bluish ultraviolet light on them. The transformation procedure of this lab uses a plasmid. A plasmid is a small, circular piece of DNA, and bacteria often have several plasmids in addition to their one large chromosome. Plasmids contain genes that may benefit the bacteria, such as giving the bacteria the ability to live in saltier environments. Bacteria are also able to transfer plasmids from cell to cell through conjugation.

The plasmid used in this lab is named pGLO because it contains the gene for producing GFP. The plasmid also contains genes for resistance to the antibiotic ampicillin, and a regulation system that can control when GFP is produced.

The "bla" gene codes for the enzyme beta-lactamase. Beta-lactamase can degrade ampicillin, so this gene gives a bacterium resistance to ampicillin; this gene is turned on all the time. Any cells that take up and express pGLO can grow on plates containing ampicillin.

Cells expressing the pGLO plasmid will also have the araC gene that codes for the araC regulatory protein; this gene is also turned on all the time. The araC protein will bind to the promoter of the arabinose operon. The arabinose operon normally has the araA, araB, and araD genes that are involved in arabinose metabolism, but these genes have been replaced with the GFP gene in the plasmid pGLO.

When the araC protein binds to the promoter of arabinose, it shuts down expression of the operon (the GFP gene in this case). So, GFP is normally

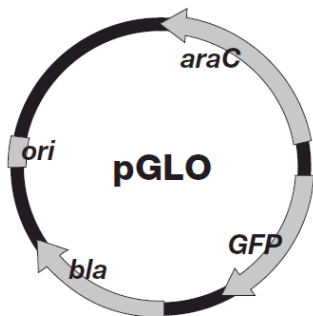

explorer.bio-rad.com
Duplication for classroom use only

turned off as is shown in the first level of the figure.

When the sugar arabinose is present, it binds to the araC protein (shown in the second level). When arabinose binds to the araC protein, the arabinose changes the shape of the protein, so that now araC protein allows the RNA polymerase (RNA pol) to bind to the arabinose promoter (as shown in the third level), turning on the expression of the GFP gene.

- Level 1: The GFP gene is turned off by the araC protein binding to the promoter (PBAD).
- Level 2: Arabinose is now present & binds to araC, changing the promoter and turning GFP on.
- Level 3: RNA polymerase can now bind to the GFP promoter.
- Level 4: Messenger RNA is made from the GFP gene.

In the fourth level of the figure, RNA pol makes mRNA from the GFP gene, allowing the gene's expression. *E. coli* expressing the pGLO plasmid in the presence of the sugar arabinose should fluoresce under UV light. *E. coli* with or without the plasmid will not fluoresce in media without arabinose.

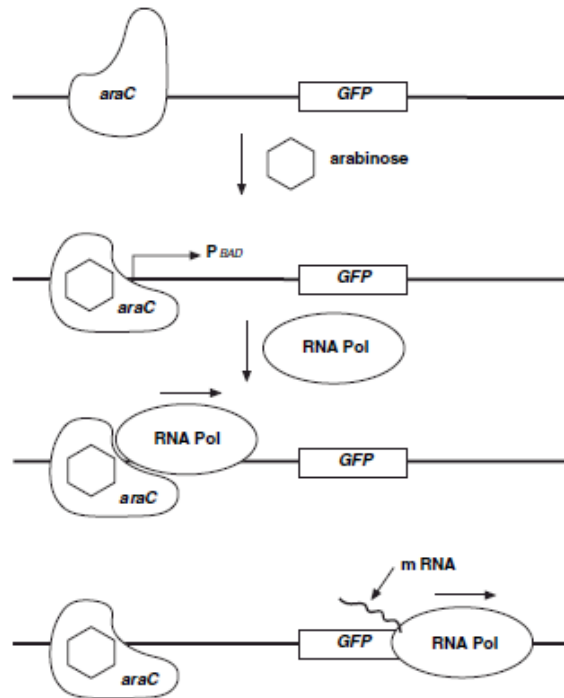

explorer.bio-rad.com
Duplication for classroom use only

Preliminary questions

1. Define “horizontal gene transfer.”
2. Briefly explain what happened in Frederick Griffith's 1928 experiment.
3. Which of the plates in this experiment do you expect will host relatively-unchanged *E. coli*? Why?
4. Which of the plates in this experiment do you expect will host genetically-transformed *E. coli*? Why?
5. Which two plates are hosting transformed bacteria?
6. What is meant by a control plate?
7. Which two are control plates?

Materials, per pair

- 1 LB agar¹ plate containing *E. coli*
- 1 sterile LB agar plate
- 2 LB/amp plates (contain ampicillin)
- 1 LB/amp/ara plate (contains ampicillin and arabinose)
- 2 microcentrifuge tubes (one for +pGLO, one for -pGLO)
- CaCl₂ transformation solution
- LB nutrient broth
- Sterile transfer pipettes
- Crushed ice bath
- 42°C water bath
- pGLO plasmid (kept at front table)

Instructions

1. Label your plates as follows. Include your name and date.:

LB plate: -pGLO
One LB/amp plate: -pGLO
One LB/amp plate: +pGLO
LB/amp/ara plate: +pGLO



Figure of plates from L. Thomas. 2012. pGLO Transformation Procedure. North Seattle Community College. Accessed 2018.

2. Label the microcentrifuge tubes as “+pGLO” and “-pGLO.”
3. Add 250 μ L of CaCl₂ transformation solution to both tubes.

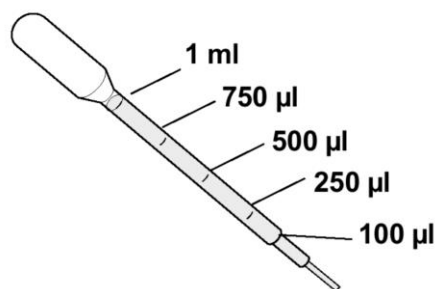
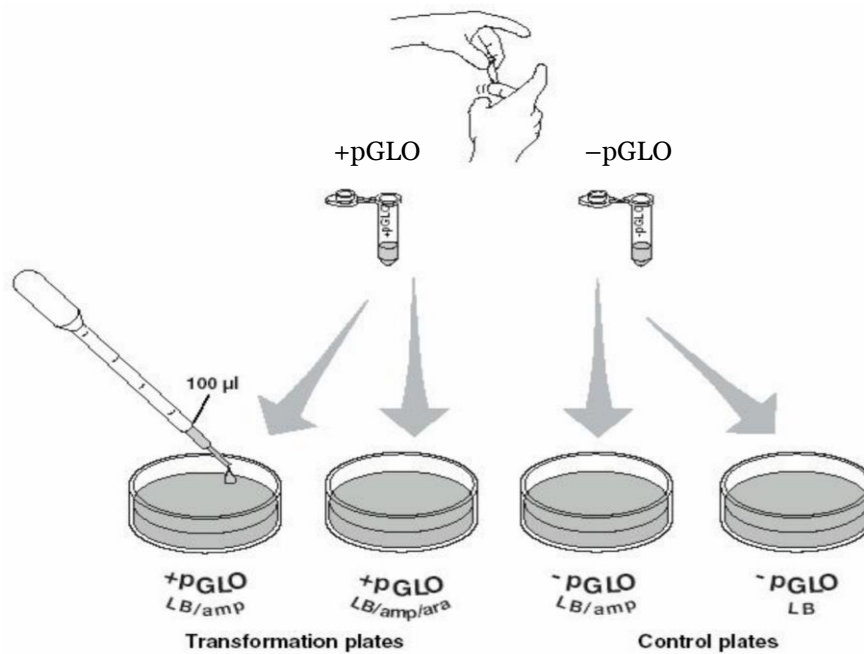

Figure of pipette from www.bio-rad.com. Accessed 2018.

¹Giuseppe Bertani created LB, and says that the LB stands for “lysogeny broth.” LB is also commonly, albeit incorrectly, taken to mean Luria broth, Lennox broth, or Luria-Bertani medium. (Bertani, G. 2004. Lysogeny at Mid-Twentieth Century: P1, P2, and Other Experimental Systems. *Journal of Bacteriology*. 186(3): 595-600).

4. Place tubes in ice bath.
5. Use a regular inoculating loop to pick up a single colony of *E. coli* from the starter plate. Transfer the colony to the +pGLO tube by spinning the loop between your finger and thumb until there are no floating chunks. Place the tube back on ice.
6. Inoculate the -pGLO tube the same way.
7. Use the plastic calibrated loop to transfer 1 μL of pGLO plasmid into the +pGLO tube.
8. Leave both tubes in the ice bath for 10 minutes.
9. Now it's time to heat shock! This will make the *E. coli* more likely to pick up any nearby plasmids. Place the two tubes in the 42°C water bath for exactly 50 seconds, and then immediately back in ice. (For the best results, the transitions should be rapid.)
10. Keep the tubes in ice for 2 minutes.
11. Remove the tubes from ice, and add 250 μL of LB nutrient broth to each tube.
12. Keep the tubes at room temperature for 10 minutes.
13. Next, flick the tubes with your fingers to mix them. Use sterile pipettes to put 100 μL of each tube onto plates, as shown below.



14. For each plate, use a regular sterile inoculating loop to spread the suspensions over the surface of the agar.
15. After a few minutes of allowing the suspension to soak into the agar, incubate the plates.

Results

Plate	Observations (numbers and colors of colonies)
LB, -pGLO	
LB/amp, -pGLO	
LB/amp, +pGLO	
LB/amp/ara, +pGLO	

Review questions

1. What is producing the green light?
2. What factors must the bacteria be exposed to, in order for you to see the green light?
3. What advantage would there be for an organism to be able to turn on or off particular genes in response to certain conditions?
4. Describe the evidence that indicates whether this genetic transformation was successful.

5. You and your partner performed the pGLO transformation lab, correctly plated the bacteria after transformation, and placed your carefully labeled plates in the 37°C incubator. Unfortunately, as an April Fools' Day prank, another student wiped all the identifying labels off the plates with an organic chemical. Assume the transformation was successful. Based on your predictions and the data you collect from the plates, is there a way to deduce which plate is which? Which plates contain bacteria with the transformed pGLO plasmid? Which plate is the LB agar? Which plates contain ampicillin, arabinose or both? What factors help you make your decision?

Plate	# of colonies	Appearance under room light	Appearance under UV light	pGLO?	Amp? Ara?
A	88	Tan	Green		
B	Lawn	Tan	White		
C	None	N/A	N/A		
D	93	Tan	White		

6. How could you improve our experiment?

7. What other things could you test using the techniques you learned in the lab?

Part 9: Water and Milk Microorganisms

Exercise 19: Testing Water and Milk

Objectives

Perform bacteriological testing procedures for water and milk, including testing for coliforms, membrane filtration, and plate counts.

Introduction

Pathogens can be introduced into foods at any stage: during growth/production at the farm, during processing (grinding, chopping, milling, etc.), during handling and packaging, and when the food is prepared in the kitchen. In many cases, small numbers of pathogenic bacteria are not dangerous, but improper storage or cooking conditions can allow these bacteria to multiply to dangerous levels.

In this lab, we will examine bacteria found in milk and water.

Milk contains carbohydrates, minerals, fats, vitamins, and proteins, and is therefore susceptible to breakdown by a wide variety of microorganisms. Several different kinds of bacteria may be present in milk, most commonly the genera *Lactobacillus*, *Micrococcus* and *Streptococcus*. Regular pasteurization is a process used to reduce microbial loads to acceptable levels in foods like milk and fruit juices. Milk that has undergone a regular pasteurization procedure can still contain bacteria. If this milk is stored at 4°C (refrigerator temperature), the bacteria are prevented from multiplying, but if the milk is left out at room temperature, the bacteria will reproduce and the milk will spoil. (If done aseptically, UHT (ultra high temperature) pasteurization can sterilize foods. This is why UHT milk can be left unopened at room temperature for long periods of time.)

There are several microorganisms of concern in milk. Several pathogens can be present in the cow's udder (*Coxiella burnetii*, *Mycobacterium tuberculosis*, *M. bovis*, *Listeria monocytogenes*, *Staphylococcus*, and *Brucella* species). More pathogens can enter milk due to fecal

contamination (*Campylobacter jejuni*, *Escherichia coli* O157:H7, *Yersinia enterocolitica*, and *Salmonella* species, most commonly *S. enteritidis* and *S. typhimurium*). Pathogens can also enter milk from people, especially through hand-milking procedures (*Mycobacterium tuberculosis*, *Streptococcus* species, and *Corynebacterium diphtheriae*).

Not all bacteria in milk are dangerous. Harmless *Lactobacillus*, *Lactococcus*, and *Streptococcus* bacteria can convert lactose into lactic acid. These bacteria are even intentionally added to milk in order to make cheeses, yogurt, buttermilk, kefir, and sour cream.

Milk is regulated by the U.S. Food and Drug Administration. Grade A milk cannot contain any more than 100,000 bacteria/mL before mixing with other milk, no more than 300,000 bacteria/mL after mixing, and no more than 20,000 bacteria/mL after pasteurization. Also, it can contain no more than 10 coliforms/mL.

Pasteurization is meant to reduce the number of living bacteria in milk. Pasteurization is also meant to destroy all pathogenic bacteria, especially those pathogens that cause undulant fever (caused by *Brucella* species), tuberculosis (caused by *Mycobacterium tuberculosis*), and Q fever (caused by *Coxiella burnetii*). Batch pasteurization requires 63°C for 30 minutes. Flash pasteurization, also called high-temperature short-time (HTST) processing requires 72°C for 15 seconds. Ultra-high temperature (UHT) processing requires heating above 135°C for 1 – 2 seconds. Successful pasteurization can be verified by testing for an enzyme called alkaline phosphatase. Sufficient

heating will have denatured all of this enzyme.

We will use serial dilution and then plate count techniques to count the number of bacteria in the milk sample.

One component of potable water quality analysis is the presence or absence of human pathogenic bacteria that are transmitted through the fecal-oral route, i.e., mainly intestinal pathogens. Since it is difficult and expensive to routinely examine waters for the presence of every type of pathogen, it is more practical to screen the water for the presence of fecal contamination by testing for the presence of an indicator microorganism. Indicator microorganisms are ones that have the following properties:

- a) the microorganism is not found in water and will be present in the water only when a contamination event has occurred; and
- b) the density of the microorganisms present should be proportional to the degree of contamination.

In the 1890s, it was suggested that *Escherichia coli* should be used as an indicator microorganism to detect the presence of pathogenic bacteria through the fecal-oral route. This bacterium was selected due to the work of Theodore Escherich in the 1880s. Escherich found that *Bacillus coli*, (now known as *E. coli*) was distributed in the intestines (i.e., an enteric bacterium) and feces of animals¹ and thus meets the properties of the indicator microorganism described above. Today, some water quality standards are still based on the detection of *E. coli* and/or related bacteria termed “coliforms.”

Many different techniques can be used to detect the presence of these indicator microorganisms. Such techniques are ones that should have the following properties:

The technique should be sensitive to detect the presence of the indicator, even at low concentrations. The technique needs to be able to process large amounts of water. The technique should be easy, cheap and can detect the presence

of the indicator quickly.

In 1951, Goetz and Tsuneishi published a technique that used cellulose nitrate and cellulose acetate membranes as a means of capturing any bacterium present in a sample of water during filtration. This technique is still employed today.

Fecal contamination of water (and through water, contamination of food materials) is another one of the ways in which pathogens can be introduced. Coliform bacteria are Gram-negative non-spore forming bacteria that are capable of fermenting lactose to produce acid and gas. A subset of these bacteria are the fecal coliforms, which are found at high levels in human and animal intestines. Fecal coliform bacteria such as *E. coli* are often used as indicator species, as they are not commonly found growing in nature in the absence of fecal contamination. The presence of *E. coli* suggests feces are present, indicating that serious pathogens, such as *Salmonella* species and *Campylobacter* species, could also be present. The U.S. Environmental Protection Agency requires that drinking water has zero fecal coliforms. A routine sample that tests positive for fecal coliform or *E. coli* triggers repeat samples. If any repeat sample tests positive for total coliform, the water system has an acute maximum contaminant level (MCL) violation.

We will use several techniques to search for *E. coli* in water. The **first** is the presumptive test, where a water sample is added to a lactose broth, and we search for evidence of acid and gas production. (If this test shows both acid and gas production, there are further tests that can be done to confirm.) A **second** technique uses a membrane filter with a pore size of 0.45 µm, which is then incubated on an agar plate. Bacterial (and other) cells trapped on the membrane will grow into colonies that can be counted, and a bacterial density of the water samples can be calculated. **Thirdly**, we will use serial dilution and plate count techniques to count the number of bacteria in the water sample.

When reporting total and fecal coliforms in water samples, it is standard to use colony-forming units (CFU)/100 ml of sample.

¹ Escherich, T. 1886. Die Darmbakterien des Säuglings und ihre Beziehungen zur Physiologie der Verdauung (Enterobacteria of

infants and their relation to digestion physiology). Stuttgart.

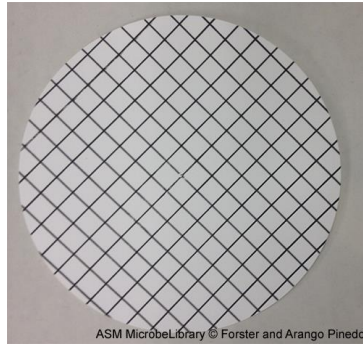
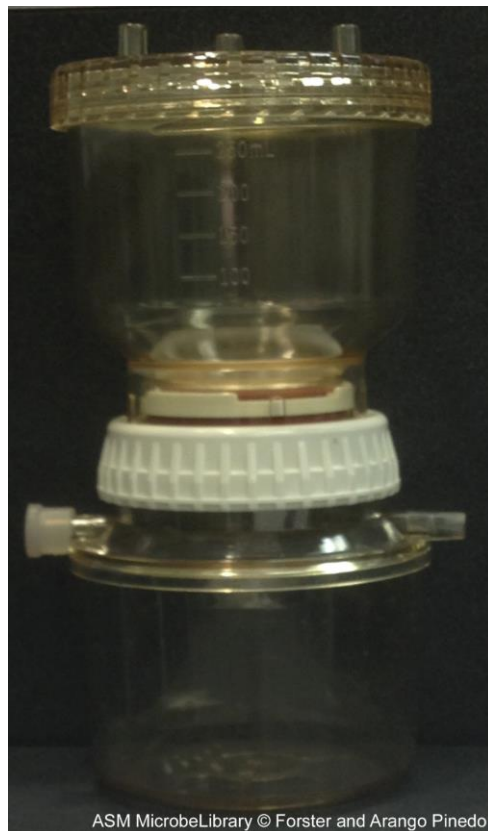

Figure of nitrocellulose membrane. This membrane is used for the detection of total coliform and fecal coliform bacteria from samples of water. It has a 47 mm diameter and a pore size of 0.45 μm . The small pore size in the membrane filter will capture bacterial cells present in a sample of water during filtration. A grid is printed on the membrane to assist with counting colonies after incubation. From Forster, B. and C. Pinedo. 2015. Bacteriological examination of waters: membrane filtration protocol. American Society for Microbiology. Accessed 2018.

Membrane filtration device



Filtration Column used in membrane-filtration. This filtration column can be used for the detection of total coliform and fecal coliform bacteria from samples of water. The column is first connected to a vacuum pump. A nitrocellulose membrane is placed between the chamber and catchment vessels. The water sample is then poured into the chamber of the column. From Forster, B. and C. Pinedo. 2015. Bacteriological examination of waters: membrane filtration protocol. American Society for Microbiology. Accessed 2018.

Standard plate count and serial dilution techniques

One of the most common methods of determining the amount of bacteria in a food product is a standard plate count. In this method, serial dilutions of the food are plated on general purpose and/or differential/selective growth media. Bacterial colonies are then counted, and the number of CFUs (colony forming units) in the original undiluted sample is calculated. (CFUs are used as a measure of the number of bacteria to take into account that one colony might be the product of more than a single bacterium).

Serial dilution is a technique that is used to produce very dilute solutions without the necessity of measuring very small quantities of liquids. It is a series of stepwise dilutions, in which one first dilutes a solution, then dilutes the dilution, then dilutes the dilution of the dilution and so forth. The dilution factor at each step is usually constant, resulting in a geometric progression of concentration. An example of a serial dilution is seen below. In this example, each dilution is a 10-fold dilution (transferring 1 ml into 9 ml of H₂O results in a 1/10 dilution; i.e., 1 ml in a total volume of 10 ml).

Serial dilutions are often used in standard plate counts because the number of bacteria in a sample (water, food, or a medical sample such as a urine or a fecal sample) is unknown. The sample is diluted to obtain a number of CFU that supplies statistically significant results, yet is still easily

countable. The general recommendation for a countable plate is between 30 – 300 CFUs/plate. (Because milk often contains more bacteria than water, and these bacteria may reproduce after pasteurization, we will dilute the milk more than the water sample.)

After dilutions are prepared, a set amount of liquid (typically between 0.1- 1 ml) is spread out over the surface of an agar plate, and then incubated to allow for bacterial growth.

CFU counts from these diluted plates are used to calculate the number of bacterial cells/ml in your original (undiluted) sample. If you plate a full milliliter (ml) of your dilution, you would simply multiply the number of CFU counted by the dilution factor of the plate you counted. For example, I count 55 CFU on a plate diluted 1:1000 to which I added a 1 ml of my dilution. My calculation is $55 \times 1000 = 55,000$ CFU/ml.

However, it is important to note that we do not always plate a full ml (it can be difficult to get that much liquid to be absorbed into an agar plate). Therefore an additional calculation is often necessary to be able to express your results as cells/ml. If you plate 0.1 ml of sample, you will need to multiply the number of CFUs by 10 to determine # CFUs/ml. If you plate 0.5 ml of a sample, you will need to multiply by 2 to determine the number of CFUs/ml.

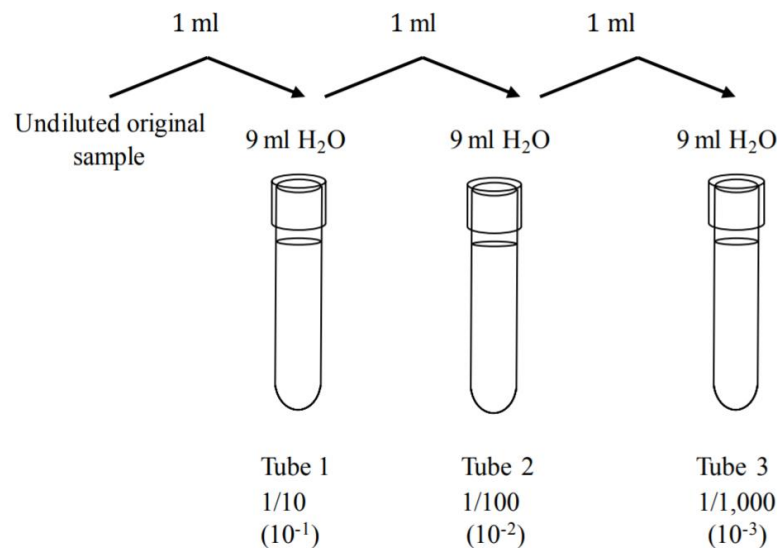
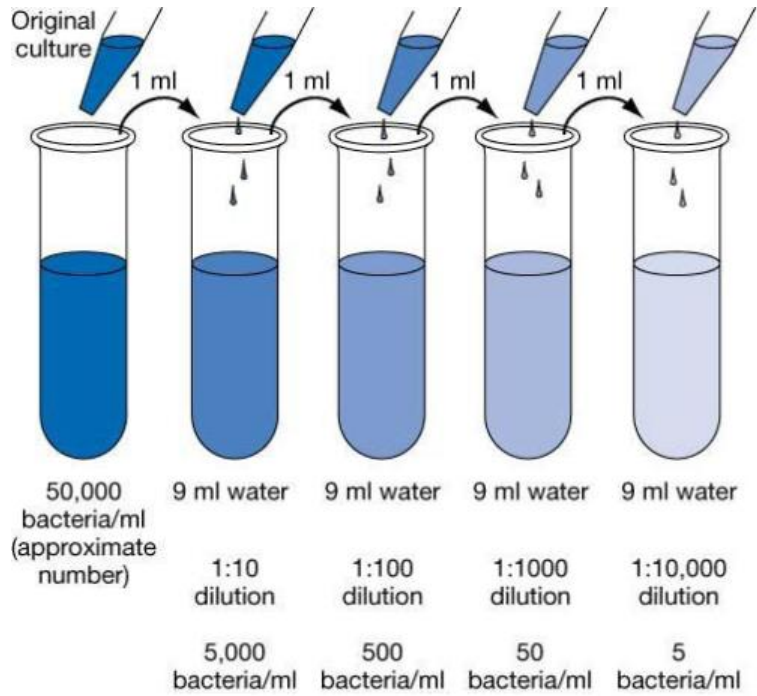
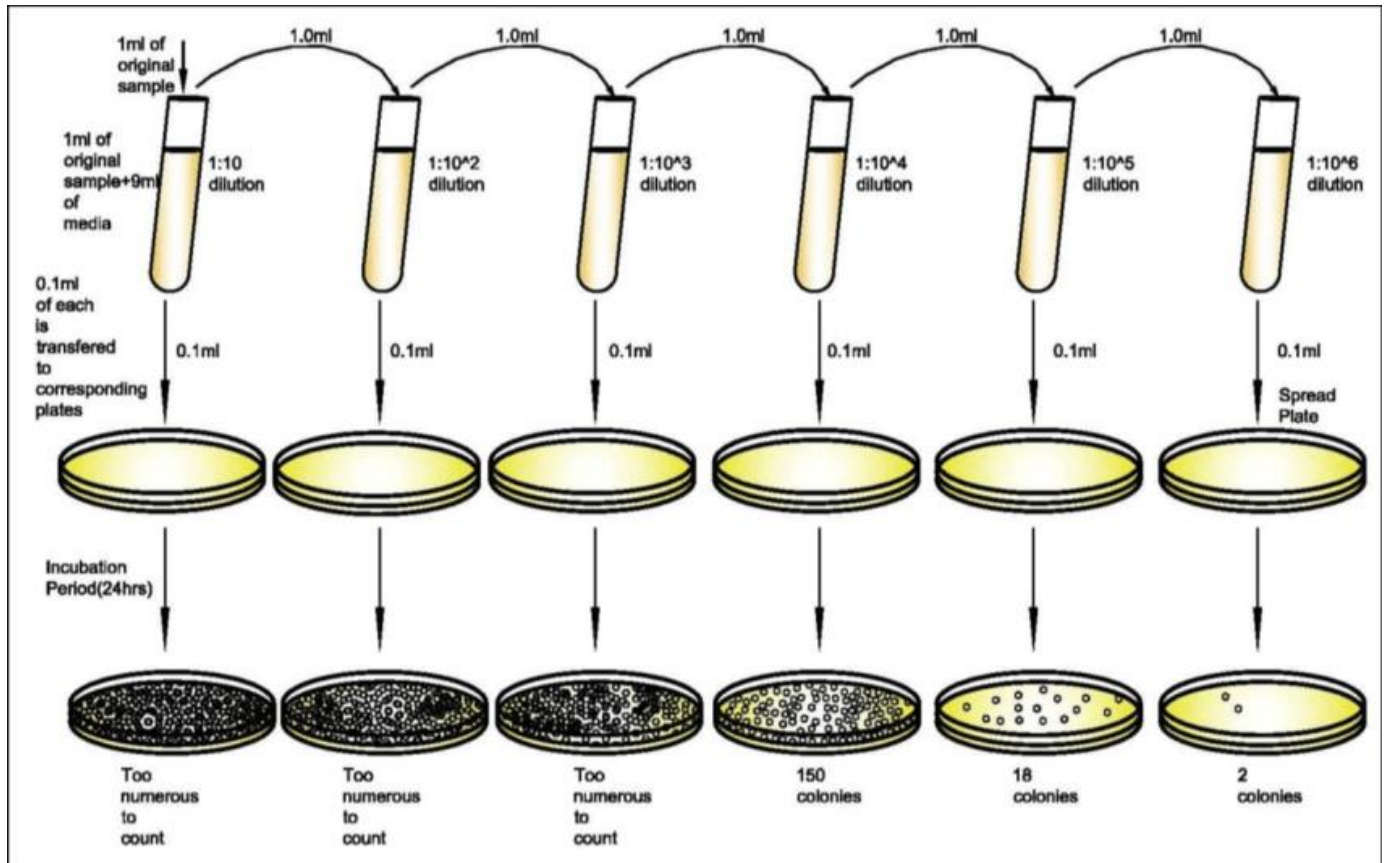

Figure of serial dilution from Petersen, J. and S. McLaughlin. 2016. Laboratory Exercises in Microbiology: Discovering the Unseen World Through Hands-On Investigation. CUNY Academic Works. Accessed 2018.



A second figure of serial dilution from Biotechnlgy. Tumblr. Accessed 2018.



A third figure of serial dilution from Hester, et al. 2014. Accessed 2018.

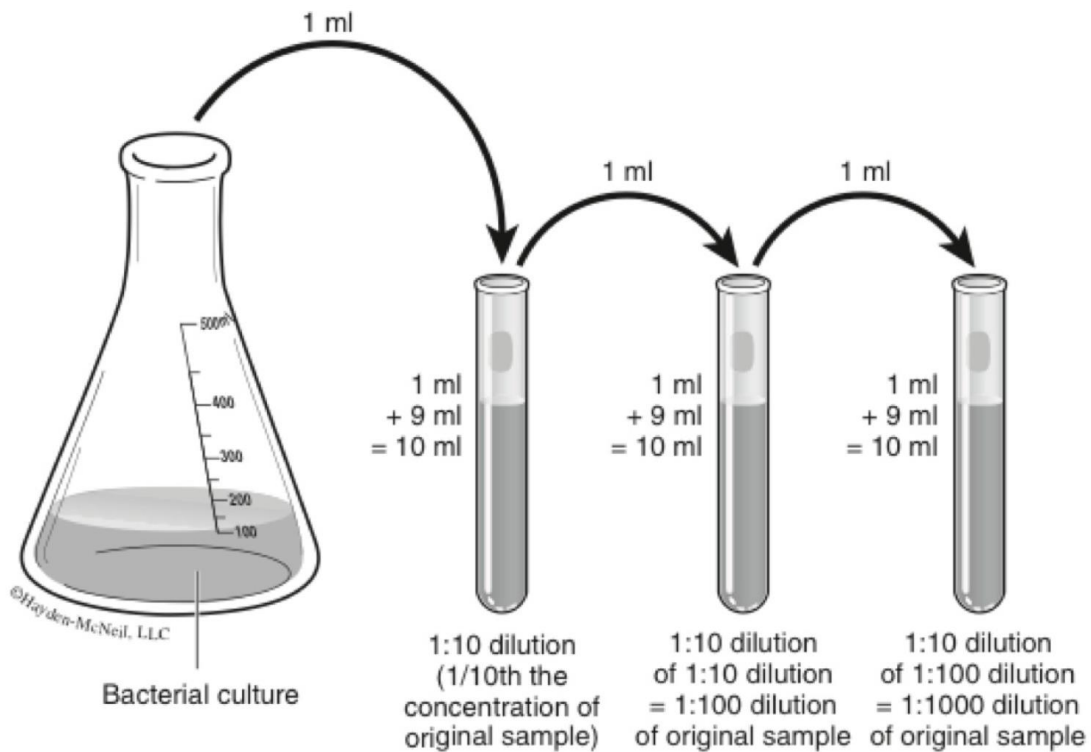

A fourth figure of serial dilution of an initial sample or culture, to obtain solutions that are 1/10th, 1/100th and 1/1000th the concentration of the initial sample (1:10, 1:100, and 1:1000 dilutions respectively). For each dilution, tubes initially have 9 ml of liquid in them so that the final volume will be 10 ml after the addition of 1 ml of culture or diluted culture. From Hester, et al. 2014. Accessed 2018.

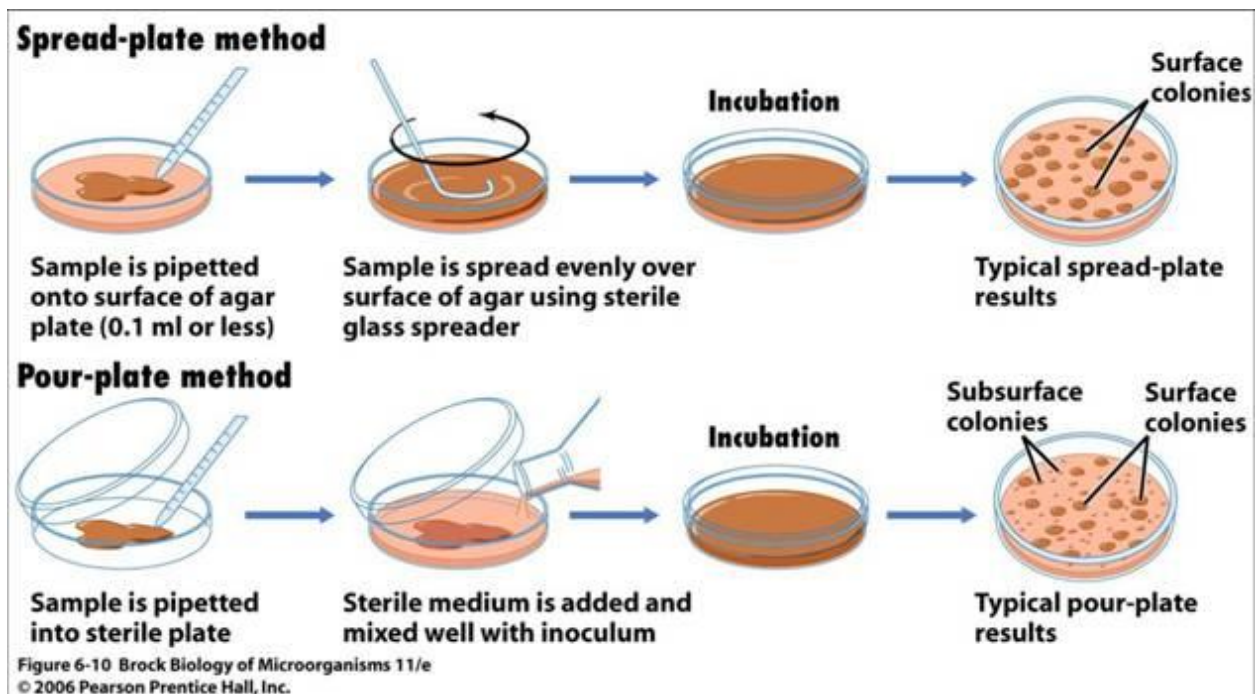

Figure showing plate with sample added and agar poured on top. From Ternopil State Medical University, Ukraine. Accessed 2018.

Materials, per student

- 4 melted agar deeps
- 4 petri dishes
- 1 phenol red lactose broth with Durham tube
- 2 pipettes
- 3 sterile water tubes, 9mL each
- 1 membrane filter
- 1 small petri plate of EMB agar

Instructions

1. Write down information about your samples.

Source of water: _____

Source/brand of milk: _____

Type of milk: _____

Last date for sale: _____

Presumptive test of water:

2. Pipette 1 mL of water sample into phenol red lactose broth. Incubate the tube.

Membrane filtration test of water:

3. Use sterile water to rinse out the upper chamber of the filter device.
4. Place the filter in its proper location: Be sure that you can see tiny ridges (almost like a nail file) on the top of the filter support. Use sterile forceps to remove the backing paper from the filter. Place the filter with its grid facing up. Reassemble the device.
5. Pour 100 mL of your water sample into the upper chamber.
6. Use the vacuum pump to make the water flow more efficiently.
7. Use sterile forceps to carefully remove the filter. Place the filter, with its grid facing up, on the surface of the EMB agar plate.
8. Incubate the plate.

Plate count method for water:

9. Label your materials.
10. Pipette 1 mL of original water sample into an empty petri dish. Add one melted agar deep, and allow to cool.
11. Pipette 1 mL of original water sample into 9 mL of sterile water. This makes a 1:10 dilution of your water.
12. Pipette 1 mL of the 1:10 dilution into a second empty petri dish. Add one melted agar deep, and allow to cool.
13. Incubate the plates.

Plate count method for milk:

14. Label your materials.
15. Pipette 1 mL of original milk sample into 9 mL of sterile water. This makes a 1:10 dilution of your milk.
16. Pipette 1 mL of the 1:10 dilution into 9 mL of sterile water. This makes a 1:100 dilution of your milk.
17. Pipette 1 mL of each dilution into separate empty petri dish. Add one melted agar deep to each, and allow the plates to cool.
18. Incubate the plates.

Observing results after incubation

1. Examine the presumptive test of water. Look for evidence of acid and gas. (If the tube is positive for both, consider streaking a loop of the broth onto EMB for a confirmed test.)
2. Examine the EMB plate containing the water filter. Count the coliform colonies, if any. (Hint: What would *E. coli* look like on EMB?) Calculate the coliform concentration in the original water sample.
3. Examine the plates from the serial dilution of water and milk. Count whichever plates contain 30–300 colonies. On these plates, count any colony, even the tiniest speck. If a plate contains fewer than 30 colonies, record this as “too few to count” (TFTC). If a plate contains more than 300 colonies, record this as “too numerous to count” (TNTC).
4. Calculate the original concentration of CFU/mL in the water and milk samples.
5. Share your results with the class.

Water results

Presumptive test: _____ Results of confirmed test, if done: _____

Number of coliforms on water filter: _____ # coliforms / mL = _____

Plate count results:	1:1 plate	1:10 plate
	_____	_____
Calculation of CFU / mL:	_____	_____

Milk results

Plate count results:	1:10 plate	1:100 plate
	_____	_____
Calculation of CFU / mL:	_____	_____

Review questions

1. What is the source of most pathogens that might contaminate a water supply?
2. Define coliforms.
3. What is one of the most well-known fecal coliforms?
4. Why is water tested for fecal coliforms, rather than tested for specific pathogens?
5. Must water be sterile to be safe to drink? Why?
6. How does water filtration treatment work?
7. What are common water disinfection treatments?
8. What are three ways that milk commonly becomes contaminated with pathogens?

9. Name several pathogenic bacteria that are often found in milk.

10. What is pasteurization?

11. What is the purpose of pasteurization?

12. How can we determine whether milk has been adequately pasteurized?

13. What are several cultured or fermented dairy products?

14. What is ultra-high temperature (UHT) treatment for milk? How is it different from HTST treatment?

Sources: Image sources are cited throughout.

Basic Malaria Microscopy (part I and II). 1991. WHO - OMS. <http://www.nzdl.org/gsd/collect/helid/archives/HASH0141.dir/p35b.gif>. Accessed 2018.

Bertani, G. 2004. Lysogeny at Mid-Twentieth Century: P1, P2, and Other Experimental Systems. *Journal of Bacteriology*. 186(3): 595-600.

Cain, D. 2016. Collin College Microbiology. <http://faculty.collin.edu/dcain/CCCCD%20Micro/index.htm> Accessed 2018.

Carr, S. M. 2011. Thymine-thymine dimers. https://www.mun.ca/biology/scarr/Thymine-Thymine_Dimers.html Accessed 2019.

Carlson Stock Art. <https://www.carlsonstockart.com/> Accessed 2018.

Cuthbertson, M. 2016. Lab: Pond Water Organisms. Ken Caryl Middle School. Littleton, Colorado. <https://sites.google.com/a/jeffcoschools.us/mr-cuthbertson/announcements/11316labpondwaterorganisms50pts> Accessed 2018.

Electron Microscopy Sciences. n.d. Bacti-Cinerator IV Inoculating Loop and Needle Sterilizer. Instructional Manual. Cat. 62420-Series. Hatfield, PA. <https://www.emsdiasum.com/microscopy/technical/manuals/62420.pdf> Accessed 2018.

Forster, B. and C. Pinedo. 2015. Bacteriological examination of waters: membrane filtration protocol. American Society for Microbiology. <http://www.asmscience.org/content/education/protocol/protocol.3982> Accessed 2018.

Goetz, A., Tsuneishi, N., Kabler, P.W., Streicher, L., and Neumann, H.G. 1951. Application of Molecular Filter Membranes to the Bacteriological Analysis of Water *Journal (American Water Works Association)*. 43: 943-984.

Grade A Pasteurized Milk Ordinance. 2015. U.S. Department of Health and Human Services, Public Health Service, Food and Drug Administration. <https://www.fda.gov/media/99451/download> Accessed 2018.

Hardy Diagnostics. 1996. Hardydisk™ Antimicrobial Sensitivity Test (AST) https://catalog.hardydiagnostics.com/cp_prod/Content/hugo/HardyDiskASTProceduresandChart.pdf Accessed 2019.

Hester, L., M. Sarvary, and C. Ptak. 2014. Mutation and Selection: An Exploration of Antibiotic Resistance in *Serratia marcescens*. *Proceedings of the Association for Biology Laboratory Education* 35: 140-183.

Hudzicki, J. 2009. Kirby-bauer disk diffusion susceptibility test protocol. American Society for Microbiology. <http://www.asmscience.org/content/education/protocol/protocol.3189> Accessed 2018.

Kaiser, G. E. 2017. The Grapes of Staph: Doc Kaiser's Microbiology Website. The Community College of Baltimore County. <http://faculty.cbcmd.edu/~gkaiser/> Accessed 2018.

Lindquist, J. 2014. Selected Aseptic Transfer Techniques. University of Wisconsin – Madison. <https://www.jlindquist.com/generalmicro/102aseptictechnique.html> Accessed 2018.

M. J. LeBoffe and B. E. Pierce. 2011. Exercises for the Microbiology Laboratory. Morton Publishing Company. Accessed 2018.

Lysogeny broth. Wikipedia. https://en.wikipedia.org/wiki/Lysogeny_broth Accessed 2018.

Macedo. 2016. Colony Morphology. Wikimedia Commons. https://commons.wikimedia.org/wiki/File:Colony_morphology.svg Accessed 2018.

Macedo. 2016. Hanging Drop Slide. Wikimedia Commons. https://commons.wikimedia.org/wiki/File:Hanging_drop_slide.svg Accessed 2018.

MedlinePlus.gov. 2018. Pinworm Test. <https://medlineplus.gov/ency/article/003452.htm> Accessed 2019.

Microscope Central. Nikon E100 LED Binocular Microscope. <https://microscopecentral.com/> Accessed 2018.

Misconceptions about HIV/AIDS. Wikipedia. https://en.wikipedia.org/wiki/Misconceptions_about_HIV/AIDS Accessed 2018.

OpenStax College Microbiology. 2019. Microbiology. OpenStax CNX. <http://cnx.org/contents/e42bd376-624b-4c0f-972f-e0c57998e765@7.1>. Accessed 2019.

Petersen, J. and S. McLaughlin. 2016. Laboratory Exercises in Microbiology: Discovering the Unseen World Through Hands-On Investigation. CUNY Academic Works. http://academicworks.cuny.edu/qb_oers/16. Accessed 2018.

Shields, P. and L. Cathcart. 2011. Motility test medium protocol. American Society for Microbiology. <http://www.asmscience.org/content/education/protocol/protocol.3658> Accessed 2018.

Shreeja D. n.d. Four Main Growth Characteristics of a Pure Culture of Bacteria. Soil Management India. <http://www.soilmanagementindia.com/soil-biology/4-main-growth-characteristics-of-a-pure-culture-of-bacteria/2347> Accessed 2018.

Thioglycolate broth. Wikipedia. https://en.wikipedia.org/wiki/Thioglycolate_broth Accessed 2018.

Thomas, L. 2012. pGLO Transformation Procedure. Biol 211 Majors Cell Biology. North Seattle Community College. <http://facweb.northseattle.edu/lizthomas/Lab7Add.pdf> Accessed 2018.

Tu, A. T. 2008. Transformation of *Escherichia coli* made competent by calcium chloride protocol. American Society for Microbiology. <http://www.asmscience.org/content/education/protocol/protocol.3152> Accessed 2018.

United States Environmental Protection Agency. Total Coliforms – Ground Water & Drinking Water. Accessed 2018.